

ALCATEL VACUUM TECHNOLOGY

ADP / ADS Series Two

DRY PUMPS FOR THE SEMICONDUCTOR INDUSTRY



User's Manual



ADP/ADS Series Two dry pumps

Dear Customer,

you have just purchased an Alcatel dry pump. We thank you and are proud to include you in our customers.

This product has benefited from Alcatel's many years of experience in "semi-conductor" processes and dry pumping.



For optimum performance and to obtain full satisfaction from this equipment, we recommend that you study this manual before any intervention on your pump, in particular, the chapter on installation and start up.

APPLICATIONS :

- All "semi-conductors" processes
Stripping, Etching, PECVD, LPCVD, SACVD, MOCVD, Epitaxy
- Scientific research

ADVANTAGES :

Reduced volume and foot-print - Low operating cost -
High performances (pumping speed and ultimate pressure) -
Excellent behavior in harsh environments - Easy integration -
1/2 lobe technology - Advanced monitoring functions (Stand-by position to reduce N₂ consumption, power failure protection) -
SEMI S2-93 standard compatible (on option).

SPECIAL FEATURES :

Multi-stage Roots technology - Water-cooled multi-voltage motors -
Exhaust and utilities connections possible on top or at the rear of the pump - Alcatel Network compatible.

MANUAL REFERENCE : 106 298 GB
EDITION : 02 - February 1999

User's Manual ADP/ADS Series Two

Introduction	■ Dry pump operational principle	■ A 10
	■ ADP/ADS Series Two dry pump range	■ A 20
	■ M4 monitoring for P pump model.	■ A 30
	■ Monitoring for ADP 122 L model.	■ A 31
	■ Options	■ A 40
	■ Technical characteristics	■ A 50
	■ Accessories	■ A 60
Start-up	■ Safety instructions	■ B 00
	■ Unpacking / Storage	■ B 10
	■ Positioning the pump in the pumping installation	■ B 20
	■ Installing anti-vibration pads (accessories)	■ B 30
	■ Filling the machine oil housings	■ B 40
	■ Connection to the cooling circuit	■ B 50
	■ Inert gas purge connection (N2 plug)	■ B 60
	■ Pump power supply	■ B 70
	■ Checking the rotational direction and first pump start-up	■ B 80
	■ Connection to the pumping circuit	■ B 90
	■ J14 Remote control plug connection	■ B 100
	■ J3 Remote control plug connection (ADP 122 L) .	■ B 101
	■ Emergency stop plug connection	■ B 110
	■ RS 232 or RS 485 link wiring	■ B 120

User's Manual ADP/ADS Series Two

Operation	■ Operating modes (P model pumps)	■ C 10
	■ Operating modes (L model pumps)	■ C 11
	■ Start-up of the M4 monitoring system	■ C 20
	■ Use of the M4 monitoring system for pumping operation	■ C 30
	■ Use of the pump ADP 122 L	■ C 31
	■ The M4 monitoring system parameters	■ C 40
	■ M4 monitoring system function table.	■ C 50
	■ Water flowrate and gas purge according to main semiconductor processes	■ C 60
	■ Saving and remote loading of pump configuration (with M4).	■ C 70
	■ M4 monitoring setting for transport.	■ C 80
Maintenance	■ Safety instruction related to maintenance	■ D 00
	■ First level of maintenance	■ D 10
	■ Maintenance frequency	■ D 20
	■ Diagnosis and troubleshooting	■ D 30 to D 140
Maintenance sheet	■ Pump draining	■ E 10
	■ Exhaust maintenance	■ E 20
	■ Freeing up the ADP	■ E 30
	■ Ressetting maintenance parameters	■ E 40

User's Manual ADP/ADS Series Two

Introduction

■ Dry pump operational principle	■ A 10
■ ADP/ADS Series Two dry pump range	■ A 20
■ M4 monitoring for P pump model.	■ A 30
■ Monitoring for ADP 122 L model.	■ A 31
■ Options	■ A 40
■ Technical characteristics	■ A 50
■ Accessories	■ A 60

Dry pump operational principle

Multi-stage Roots principle

The ADP pump consists of 5 Roots type stages.
The two rotors rotate without touching each other.

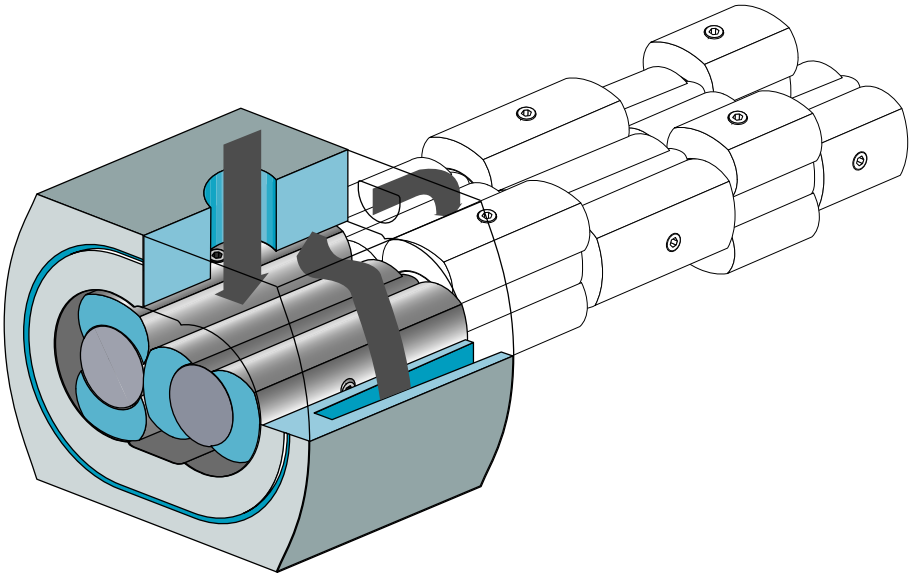

The three stages on the low pressure side are called "LP stages" and the two stages on the high pressure side are called "HP stages".

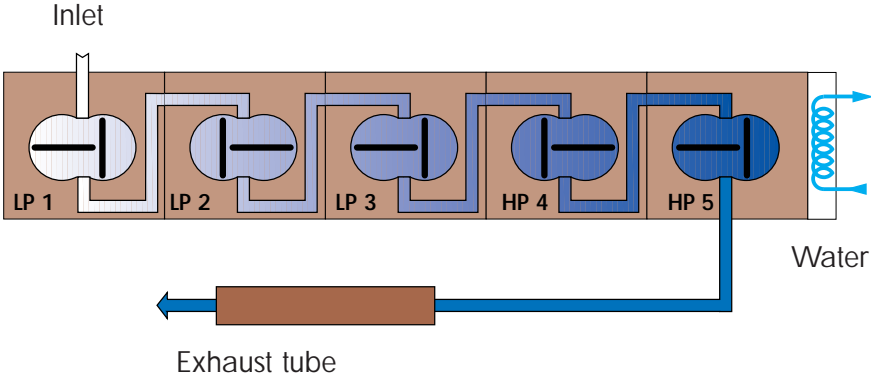

Dry pump operational principle

Tightness with environment

Tightness at low pressure side

The pump bearings on the low pressure side are fitted with ceramic ball bearings lubricated with fluorinated grease which resists high temperatures and the possible corrosion due to the application.

An overpressure zone is created around the bearing by injecting a neutral gas (Purge LP1).

This pressurization prevents pumped gases from migrating towards the bearings.

Neutral gas purging for the bearings is imperative for corrosive processes.

Tightness at high pressure side

The bearings are lubricated by oil splashing. The oil sump is sealed from stage HP5 by a trap and a deflector.

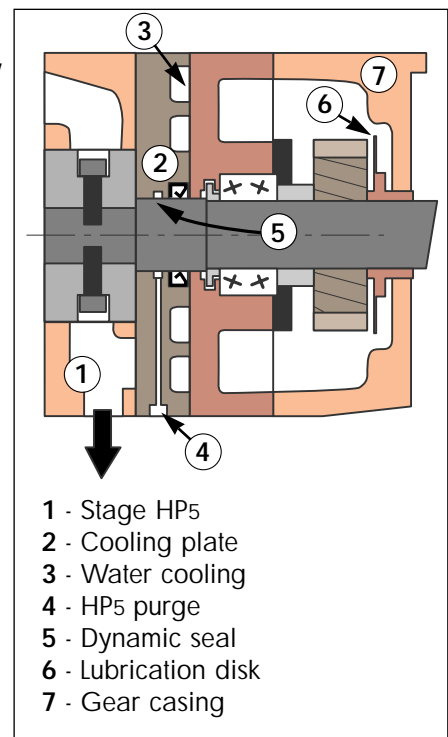

Dry pump operational principle

Tightness at motor side (shaft passage)

The vacuum tightness is ensured by the motor design with built-in jacket (hermetically sealed).

This system provides total safety regarding leaks outside the pump and requires no maintenance.

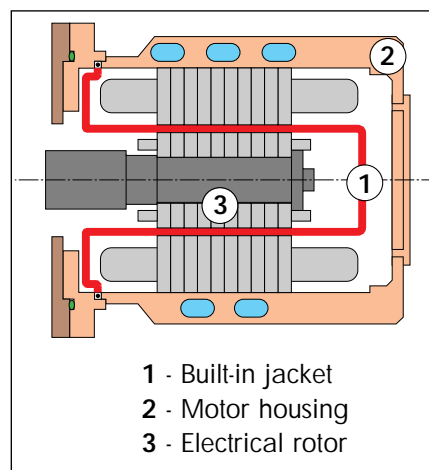

Tightness at shutdown

The pump is fitted with a antisuckback valve in the exhaust tube, preventing the exhaust being sucked back.

The pump in a pumping installation

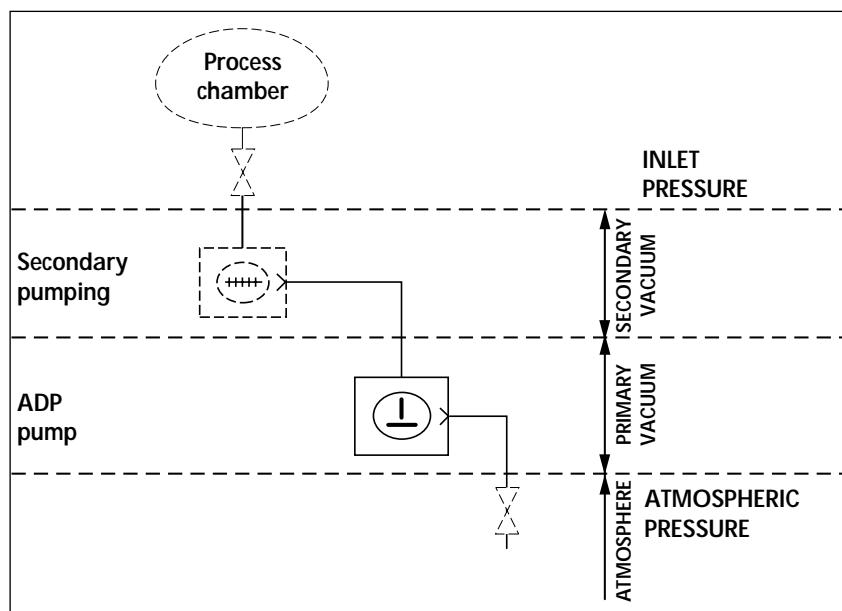

ADP/ADS Series Two dry pump range

A new range of Alcatel's dry pumps for every application

Alcatel has developed a new range of dry pumps, operating at high temperature, adapted to the different processes used in the semi-conductor industry.

The range includes:

- ADP 122, which is available in two versions:

ADP 122 P: integrated in a covered frame including: the pump, the monitoring, the hand-held remote control, facilities, the flowmeter panel, the OEM interface, the serial link.

ADP 122 L: simplified model designed for clean processes (load-lock and transfer chamber pumping).

- Two pumping groups composed of an ADP 122 P combined with a Roots to make a fully integrated system **ADS 602 P** and **ADS 1202 P**.



ADP 122



ADS 1202



ADS 602

ADP/ADS Series Two dry pump range

Interfaces

(for example ADP 122 P -
utilities on top)

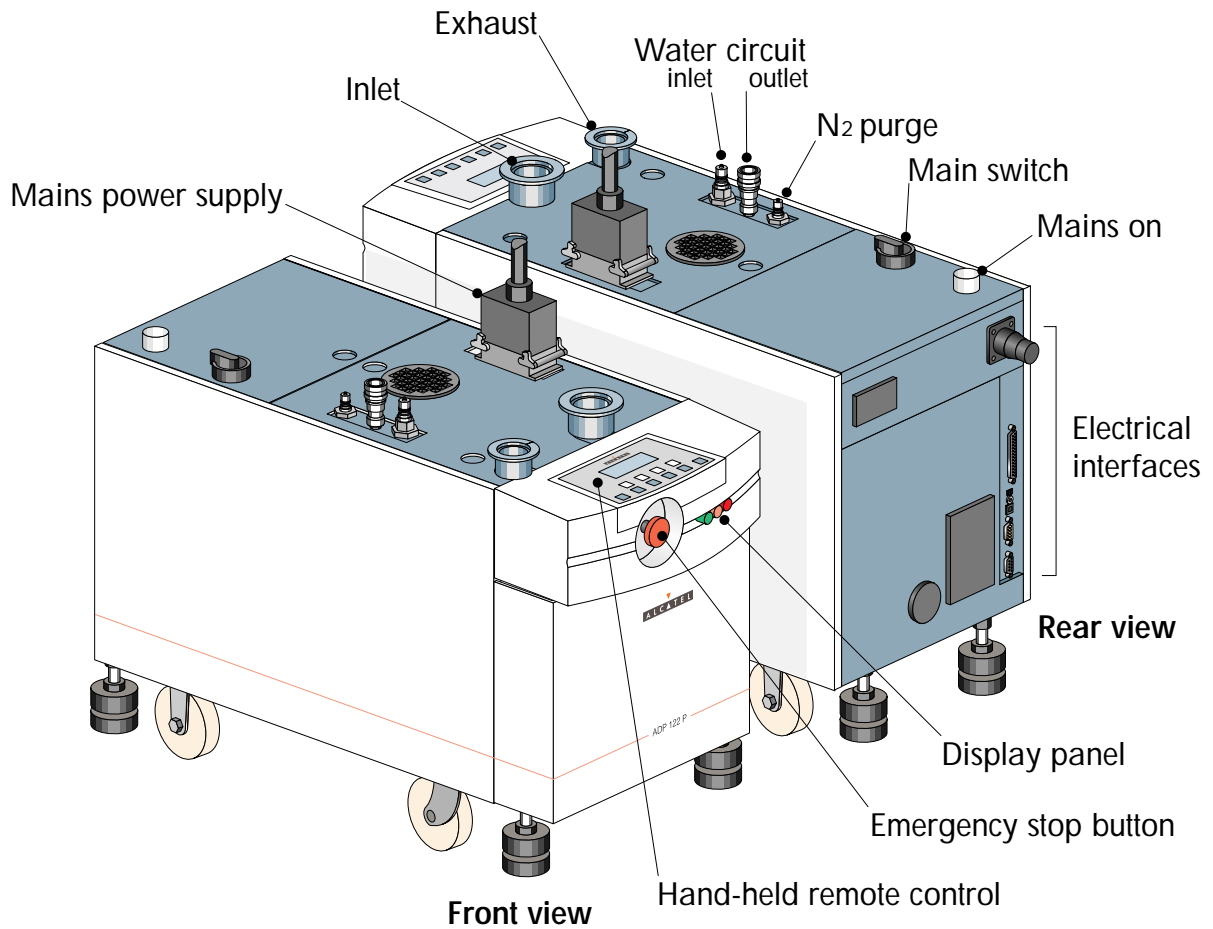

ADP/ADS Series Two dry pump range

Internal equipment of the pumps

The "P model" pumps of the Series Two range include a cooling circuit and an inert gas purge circuit.

The ADP 122 L model, especially designed for clean applications like load and transfer chamber pumping, does not include an inert gas purge circuit.

Cooling circuit (principle schema)

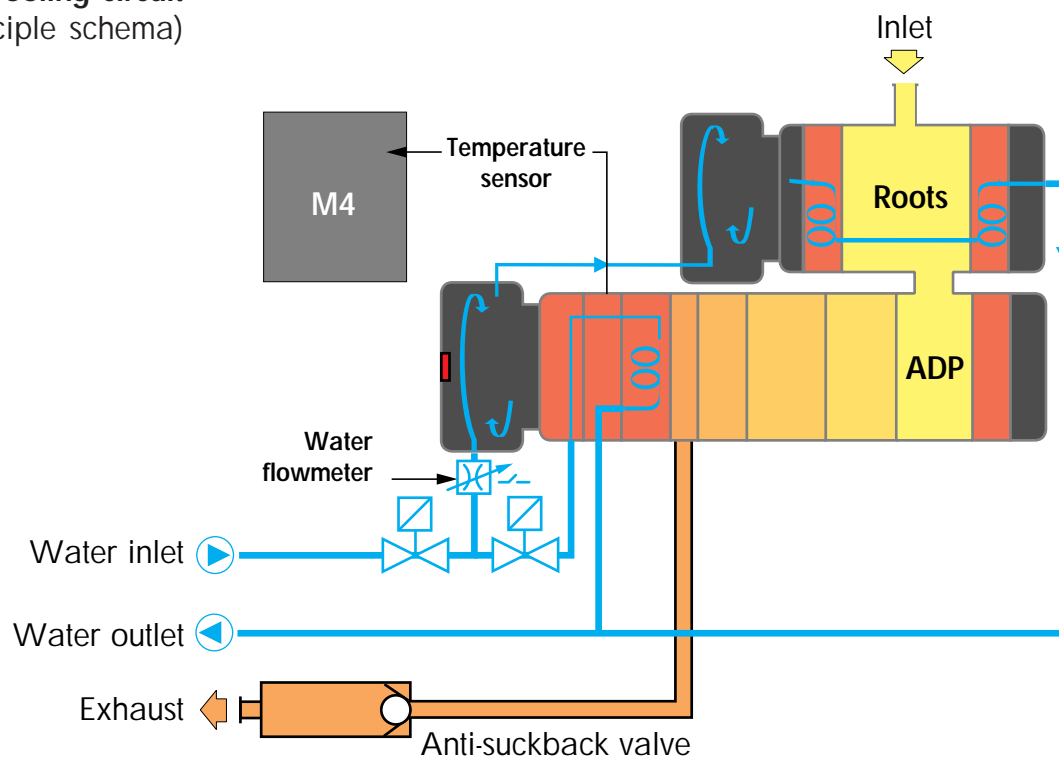

ADP/ADS Series Two dry pump range

"P" model
N2 purge circuit

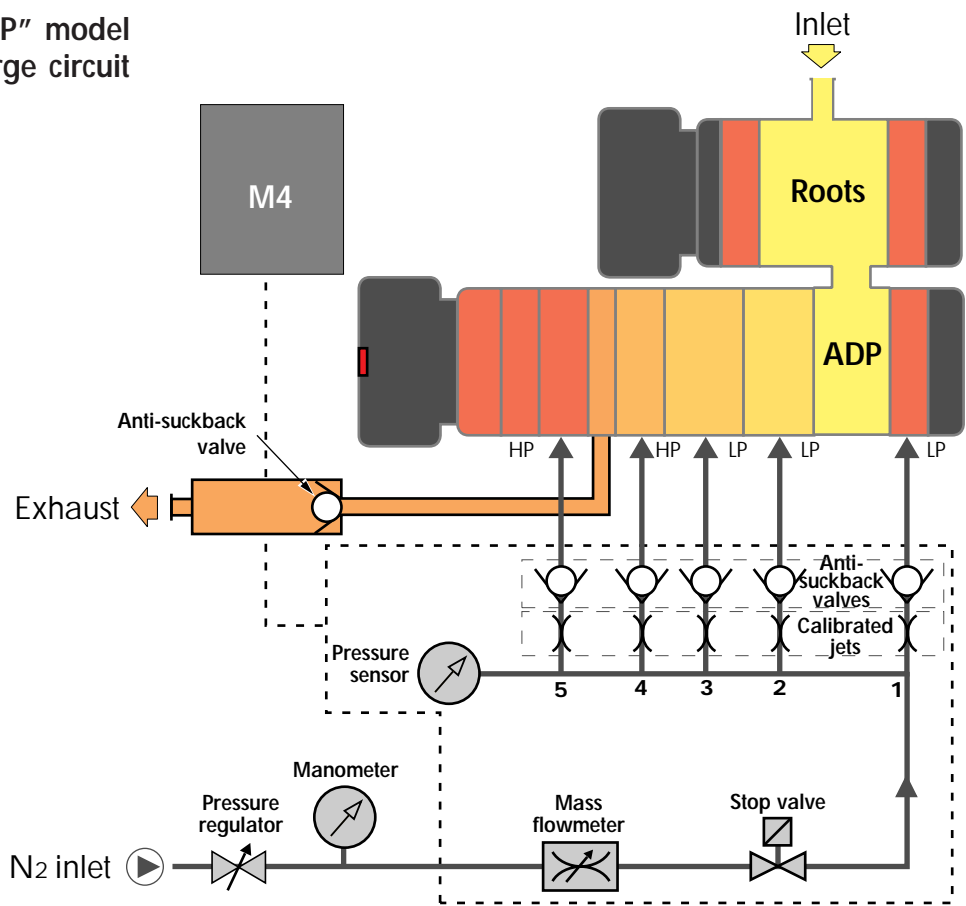

M4 monitoring for P pump model

Principle To improve the design flexibility of the products, Alcatel has developed a new generation of electrical equipment for the ADP/ADS.

Description	Electrical cabinet	Hand-held remote control
	It is located at the rear of the machine. It is linked with main power supply, ADP/Roots motors and electronic cabinet.	It ensures Man-Machine interface. It can be used either from the front or the rear of the pump and allows the access at all operation parameters.

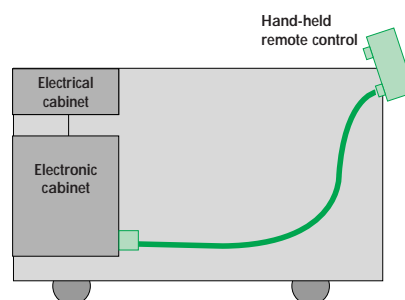

Electronic cabinet

It ensures the pump automatic operation and controls all sensors and valves. It is linked to the display panel and emergency stop button. It allows to exchange data with the hand-held remote control and ensures the interface with the supervision network. M4 monitoring can be interfaced with the main production equipments.

M4 monitoring for P pump model

M4 monitoring characteristics

- Monitoring system controlled by microprocessor
- Display (on the hand-held remote control) of parameters and messages
- Memorization of the 10 latest alerts and alarms
- RS 232 - RS 485 - Network links

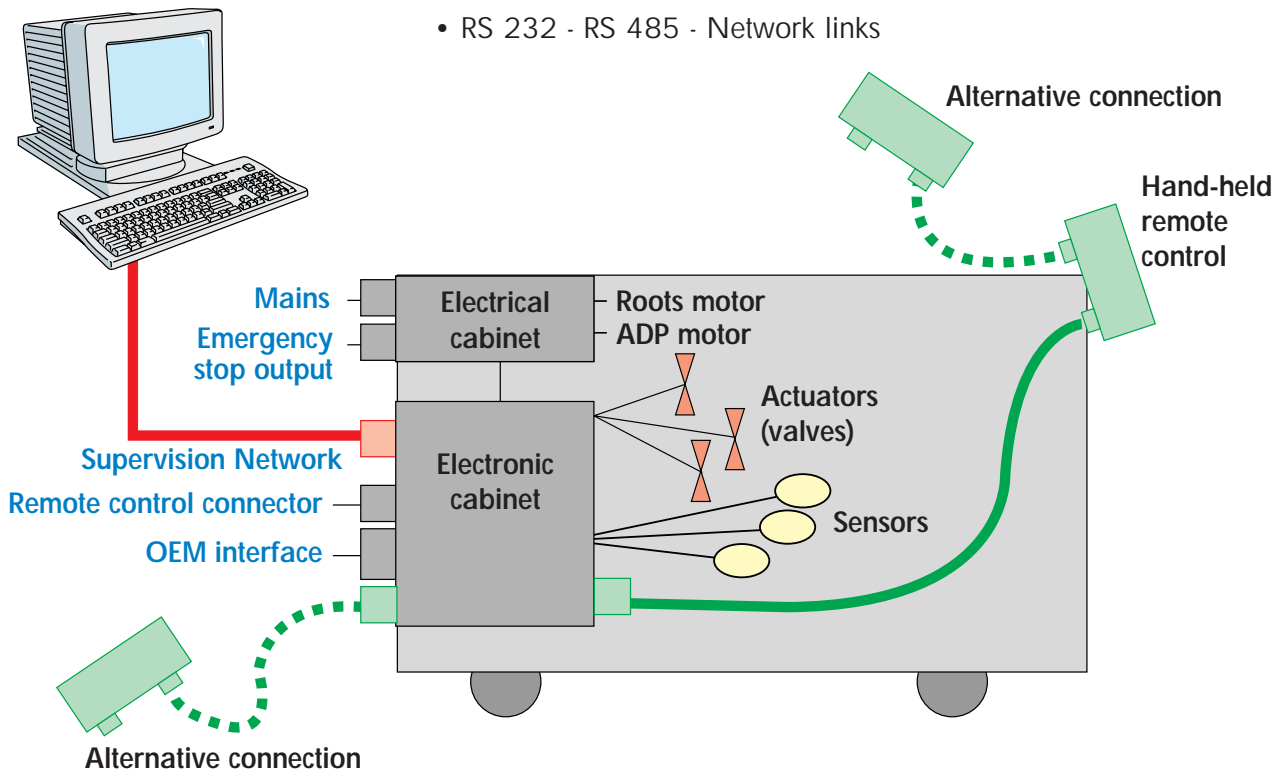

Main functions

- Motor protection
- N2 purge monitoring
- Pump temperature monitoring and control
- Thermostatic control of the pump (Temperature and water flow)
- Exhaust pressure monitoring
- Maintenance time control

Monitoring for ADP 122 L pump

Principle To improve the evolutivity of the products, Alcatel has developed a new generation of electrical equipment for ADP 122 L.

Description	Electrical cabinet	Control panel
	It is located at the rear of the machine. It is linked with main power supply, ADP motor and electronic cabinet.	It ensures Man-Machine interface.

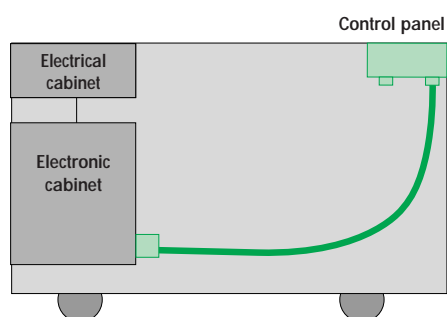

Electronic cabinet

It ensures the pump automatic operation and controls all sensors and valve.
 It is linked to the display panel and emergency stop button.
 It allows to exchange data with the control panel.
 The monitoring can be interfaced with the main production equipment.

Monitoring for ADP 122 L pump

Monitoring characteristics

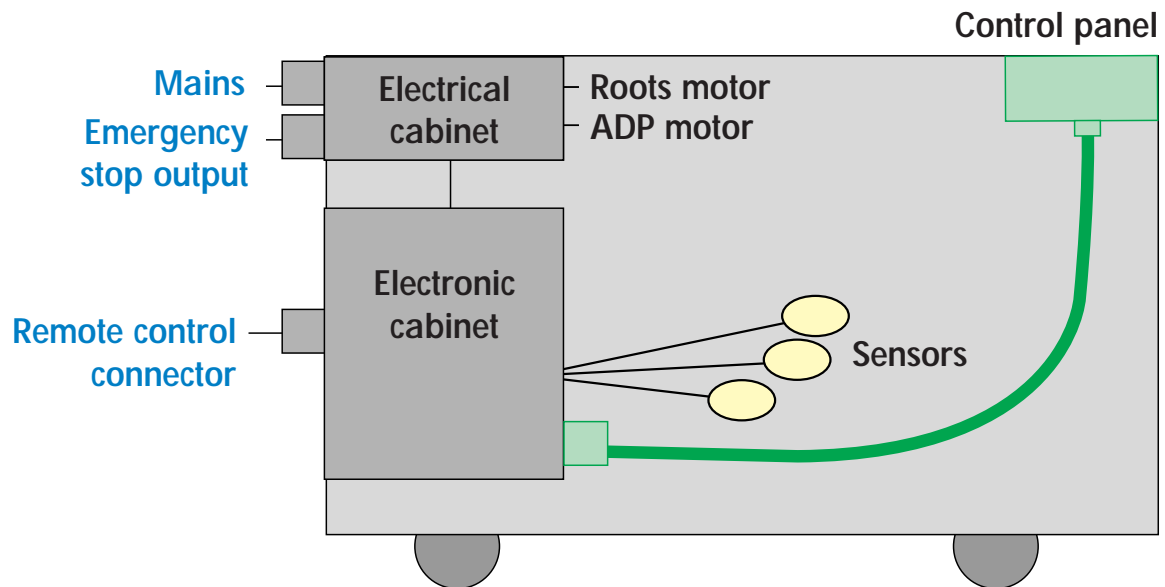

- Motor protection
- Pump temperature monitoring and control
- Maintenance time control

Options

In order to adapt the equipment to the specific conditions of the pumping installation, Alcatel offers a choice of options, factory configured when the pump is ordered.

Important note: Depending on the country, some options are integrated as standard. Please consult with your local Alcatel representative.

Facilities The different facilities connections (water, N₂, power supply) and the exhaust can be fitted on the top or at the rear of the pump.

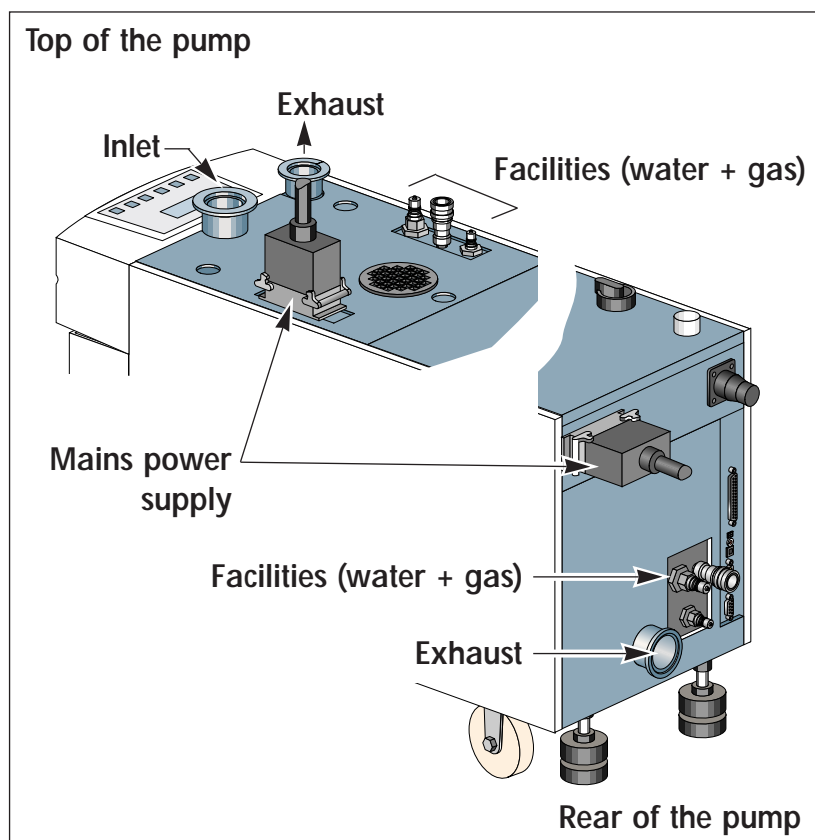

The main cable can be connected:

- directly on the terminal of electrotechnic cabinet (SEMI S2 93 compatibility),
- using a plug.

The exhaust can be fitted with an optional exhaust heater device (to be specified in configuration order) (see A 60).

Options

Hand-held remote control

The use of only one hand-held remote control is possible to successively control several Series Two pumps. In this case, the pump can be delivered without the hand-held remote control.



The hand held remote control can be ordered as an accessory (see A 60) Should two hand-held remote controls need to be connected to the same pump.

Roots converter (ADS 602 P model)

The Roots motor can be controlled by a converter, increasing the pump's efficiency and allowing the elimination of the mechanical by-pass.

Stand-by Purge

In order to reduce the overall nitrogen consumption, this option reduces the nitrogen injection in the ADP stages when processing is stopped.

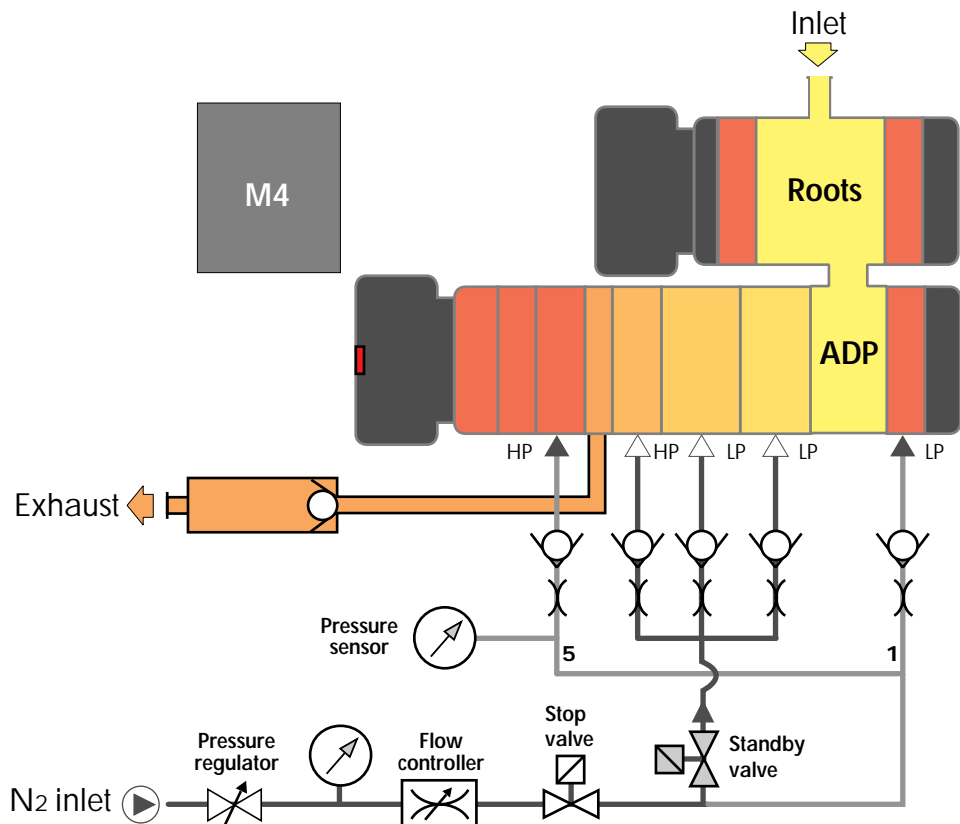

Edition 01 - November 98

Options

Power failure protection This option protects the M4 monitoring system against power failures for a delay less or equal to 3 seconds.

Exhaustable enclosure
(Required for SEMI compatibility) Compatible with SEMI S2 93 standard.
In this case, the main cable **must be directly** connected to electrical cabinet terminal (connection using a feedthrough - see **B 80**).

Technical characteristics

Characteristics	Units	ADP 122 L ADP 122 P	ADS 602 P		ADS 1202 P
			w/o conv.	with conv.	
Nominal flow-rate (50/60 Hz)	m ³ /h cfm l/mn	95/112 55.8/65.8 1583/1867	480/560 282/329 8000/9333	560/580 329/341 8000/9667	1050/1150 617/676 17500/19167
Ultimate Pressure maximale (50/60 Hz)	mbar torr Pa	$9 \cdot 10^{-3}/6 \cdot 10^{-3}$ $6.7 \times 10^{-3}/4.5 \times 10^{-3}$ $9 \cdot 10^{-1}/6 \cdot 10^{-1}$	$8 \cdot 10^{-4}/5 \cdot 10^{-4}$ $6 \cdot 10^{-4}/3.7 \times 10^{-4}$ $8 \cdot 10^{-2}/5 \cdot 10^{-2}$		$8 \cdot 10^{-4}/5 \cdot 10^{-4}$ $6 \cdot 10^{-4}/3.7 \times 10^{-4}$ $8 \cdot 10^{-2}/5 \cdot 10^{-2}$
Nominal power	kW	1.5	3		5.2
Supply voltage 3 Phases	V	200 / 480			
Consumption at ultimate pressure (50/60 Hz)	kW	1.3 / 1.5	1.8 / 2.0		3.0 / 3.2
Maximum continuous inlet pressure	mbar	50	10		5
Maximum exhaust overpressure	mbar Torr	1200 900			
N ₂ purge flow-rate*	sl/mn	0 to 50			
Cooling water	l/h	60	60		80
Rotation speed (pump)	rpm	3000 to 3600			
Pump running ambient temperaure	°C	5 to 40			
Gear boxes	ADP Roots	I I	0.35 0.7		0.35 2.05
Fluid capacity					
Inlet flange	ISO-K	DN 50 ISO-KF	DN 100		DN 100
Exhaust flange	ISO-KF	DN 40	DN 40		DN 40
Dimensions l x w x h	mm inches	830 x 390 x 580 32.7 x 15.4 x 22.8	830 x 390 x 875 32.7 x 15.4 x 34.4		995 x 390 x 985 39.2 x 15.4 x 38.8
Weight	kg	250	400		550

* "P" models only.

Technical characteristics

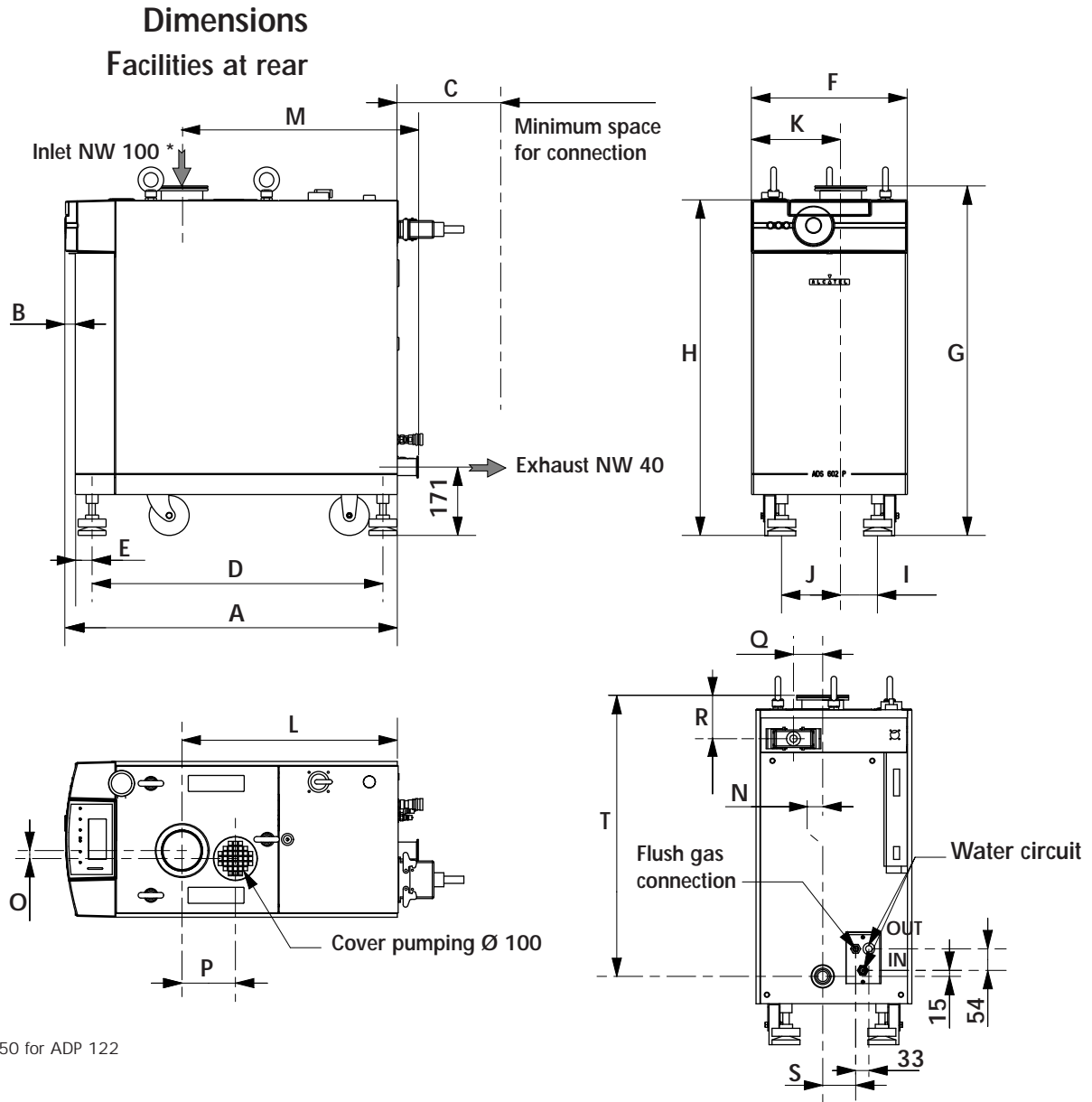

* DN 50 for ADP 122

Dimensions in inch /mm

	A	B	C	D	E	F	G	H	I	J
ADP 122	32.8 /832	1.03 /26	10.3 /260	28.7 /728	1.54 /39	15.4 /390	22.8 /580	22 /560	3.62 /92	5.8 /148
ADS 602	32.8 /832	1.03 /26	10.3 /260	28.7 /728	1.54 /39	15.4 /390	34.4 /875	33 /840	3.62 /92	5.8 /148
ADS 1202	39.5 /995	1.03 /27	10.3 /263	35.1 /891	1.62 /41	15.4 /390	38.7 /984	37.6 /955	4.7 /120	4.7 /120
	K	L	M	N	O	P	Q	R	S	T
ADP 122	8.8 /223	26.5 /674	28.6 /727	0 /0	1.12 /28	10.6 /269	2.9 /73	3.7 /94	3.25 /82	16.5 /419
ADS 602	8.8 /223	21.2 /539	23.3 /592	0 /0	0.8 /20	5.3 /134	2.9 /73	4.3 /108	3.25 /82	27.7 /704
ADS 1202	7.7 /195	21 /532	23 /585	1.12 /28	0 /0	7 /176	4 /101	4.1 /103	2.6 /72	31.3 /795

Technical characteristics

Dimensions Facilities on top

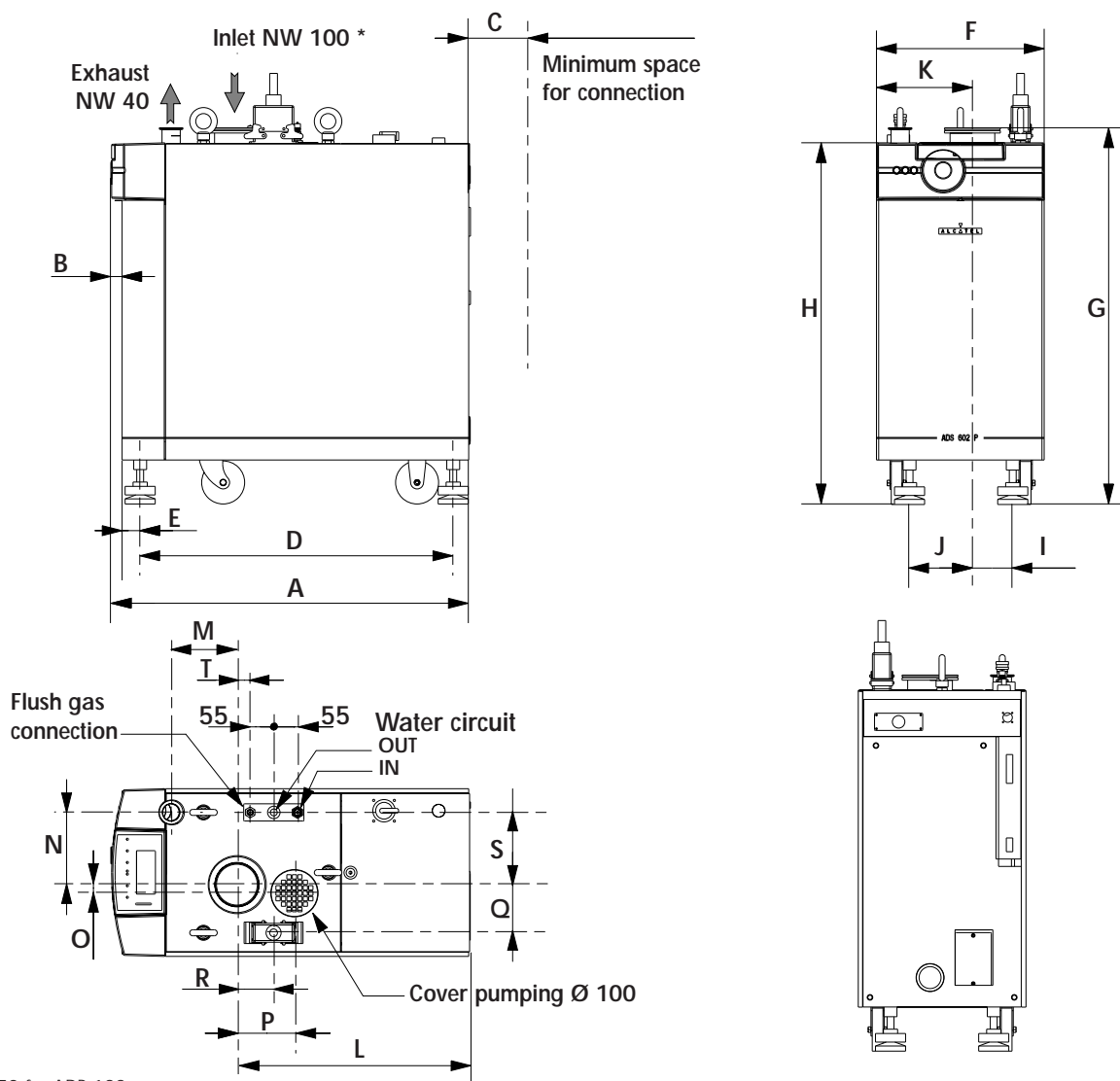

* DN 50 for ADP 122

Dimensions in inch /mm

	A	B	C	D	E	F	G	H	I	J
ADP 122	32.8 /832	1.03 /26	3.3 /83	28.7 /728	1.54 /39	15.4 /390	22.8 /580	22 /560	3.62 /92	8.8 /223
ADS 602	32.8 /832	1.03 /26	3.3 /83	28.7 /728	1.54 /39	15.4 /390	34.4 /875	33 /840	3.62 /92	8.8 /223
ADS 1202	39.5 /995	1.03 /27	3.3 /83	35.1 /891	1.62 /41	15.4 /390	38.7 /984	37.6 /955	4.7 /120	7.7 /195
	K	L	M	N	O	P	Q	R	S	T
ADP 122	5.8 /148	26.5 /674	0.7 /18	6.6 /168	1.12 /28	10.6 /269	4.4 /112	8.7 /220	6.6 /168	6.5 /166
ADS 602	5.8 /148	21.2 /539	6 /153	6.6 /168	1.12 /28	5.3 /134	4.4 /112	3.4 /85	6.6 /168	1.22 /31
ADS 1202	4.7 /120	21 /532	12.8 /324	5.5 /140	0 /0	7 /176	5.7 /144	3.2 /80.5	5.7 /144	1 /25.5

Accessories

Isolation valve at pump inlet

This valve avoids a reverse flow of gas to the chamber and increases tightness when the pump is switched off. It also isolates the running pump from the process.

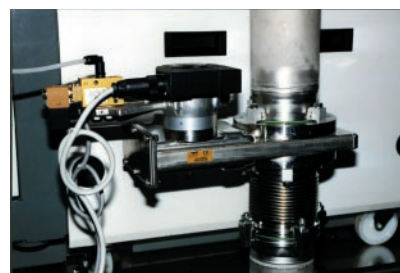

Manual valve	P/N
DN 50 ISO-KF	30108K
DN 100 ISO-F	30110K

Auto valve 24 VAC	P/N
DN 50 ISO-KF	106948
DN 100 ISO-F	107145

Anti-vibration pads

Anti-vibration pads significantly reduces the vibration rate transmitted to the floor.

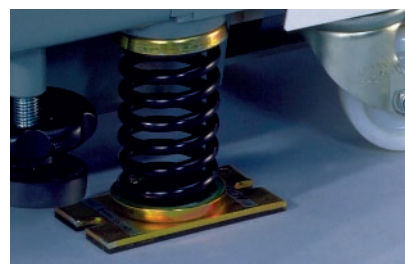

Pump	P/N
ADP 122 P or L	101838
ADS 602 P	101840
ADS 1202 P	102136

Hand-held remote control

A second hand-held remote control can be connected on the pump, a longer cable can also be used.



	P/N
Control box alone	106143
Cable 15m	107079

Accessories

Exhaust heater device

The exhaust heater is installed on the exhaust pipe which reduces deposits when pumping condensable gases. This accessory can be factory integrated on the pump as standard at time of order.

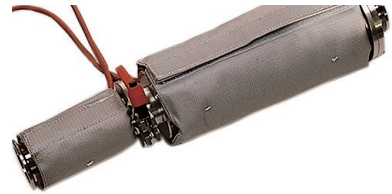

Pump	Power supply	Part Number	
		Facilities on top	Facilities at the rear
ADP 122 P	200/240 V	107136	106568
	380/460 V	107137	106569
ADS 602 P	200/240 V	107138	106568
	380/460 V	107139	106569
ADS 1202 P	200/240 V	107070	107068
	380/460 V	107071	107069

Interface boards OEM/Remote control

This device ensures direct interface between M4 monitoring and the main production equipment (Contact Alcatel).

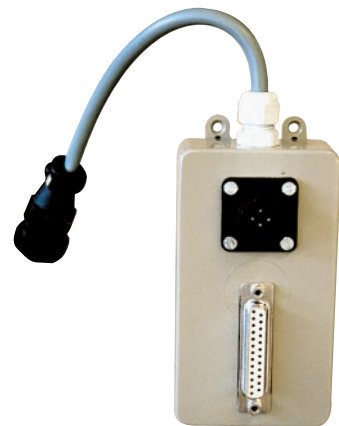

Fitting accessories

Several fitting accessories are available in Alcatel catalog (fitting rings, valves, bellows...).

User's Manual ADP/ADS Series Two

Start-up

■ Safety instructions	■ B 00
■ Unpacking / Storage	■ B 10
■ Positioning the pump in the pumping installation	■ B 20
■ Installing anti-vibration pads (accessories)	■ B 30
■ Filling the machine oil housings	■ B 40
■ Connection to the cooling circuit	■ B 50
■ Inert gas purge connection (N2 plug)	■ B 60
■ Pump power supply	■ B 70
■ Checking the rotational direction and first pump start-up	■ B 80
■ Connection to the pumping circuit	■ B 90
■ J14 Remote control plug connection	■ B 100
■ J3 Remote control plug connection (ADP 122 L) .	■ B 101
■ Emergency stop plug connection	■ B 110
■ RS 232 or RS 485 link wiring	■ B 120

Safety instructions

- The machines must be connected to an electrical installation in compliance with the decree 88-1056 dated 14 Novembre 1988.
- Our products are designed to comply with current EEC regulations. Any modification of the product made by the user is liable to lead non-compliance with the regulations, or even to put into doubt the EMC (ElectroMagnetic Compatibility) performance and the safety of the product. ALCATEL declines any responsibility for such operations.
- Before any maintenance operation is performed by a maintenance technician who has not received safety training (EMC, electrical safety, chemical pollution, etc.), isolate the product from the various energy sources (electricity, compressed air, etc.).
- The EMC performance of the product is obtained on the condition that the installation complies with the EMC rules. In particular, in disturbed environments, it is essential to:
 - use shielded cables and connections for interfaces,
 - stabilize the power supply line with meshing from the power supply source to a distance of 3m from the product inlet.
- When the main switch is set to "0", part of the equipment remains energized. Live circuits are exposed and accidental contact is possible (Energized electrical Work "Hot Work" in compliance with SEMI S2-93 Type 4). Before any maintenance operation, disconnect the main electrical cable.



Risk of electrical shock

Switch off the pump and disconnect the main cable. Do not operate inside if you are not trained and authorized

Safety instructions

- The EMO device is a pump EMO, not a system EMO, it only de-energize the pump when activated. To allow the pump to restart, turn the EMO button clockwise and pull it out. To control the system EMO, it is necessary to wire the corresponding contacts on the **J1** connector (see **B 100**).

You can stop the pump from the system EMO by wiring the corresponding terminals on **J1** connector (see **B 100**).

- Units containing control circuits are designed to guarantee normal safety conditions taking into account their usual operating environment. Take care not to insert objects in the ventilation louvers when handling units.
- When switching off an item of equipment containing capacitors loaded with over 60VDC or 25 VAC, take precautions at the access to the connector pins (single-phase motors, fitting with mains filter, frequency converter, monitoring system, etc.).
- The machines are designed so as to prevent any thermal risk to the user's safety. However, specific operating conditions may generate high pump temperatures justifying particular attention on the part of the user (external surfaces > 70°C). Hot surfaces which can cause serious burns when touched are signalled with a specific label.



Hot surface

Hot surface near the label
(pump body, exhaust tube...)

- Alcatel has no control over the types of gases passing through this pump. These are entirely under the control of the process user and/or the hardware systems integrator. Frequently, process gases are toxic, flammable, corrosive, explosive and otherwise reactive. Since these gases can cause serious injury or death, it is very important to plumb the exhaust of the pump to the facility's hazardous gas exhaust system which incorporates appropriate filters, scrubbers, etc., to insure that the exhaust meets all local air and water pollution control regulations.

Unpacking / Storage

Handling

Precautions



Risk of tilting: Even when compliance with EEC safety rules is guaranteed (normal range $\pm 10^\circ$), it is recommended to take precautions as regards the risk of tilting during product handling, installation and operation.



If the equipment has been damaged, take necessary steps with the carrier and inform Alcatel, if necessary. In all cases, Alcatel recommends that the packaging be saved, in the event that the equipment must be transported or put into prolonged storage.

Packaging dimensions

Dim. (mm)	A	B	C
ADP 122	1000	900	520
ADS 602	1000	1118	520
ADS 1202	1400	800	1300

Tolerance: ± 50 mm.

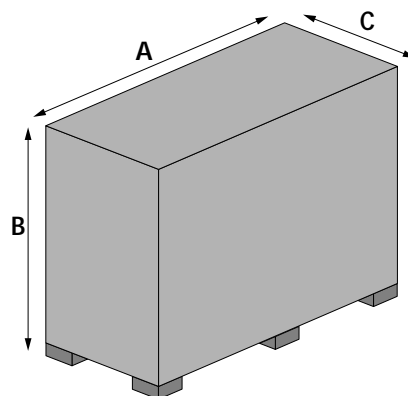

Unpacking

Remove the top of the outer crate.

Remove the fixing screws of the side panels, and remove the crate.

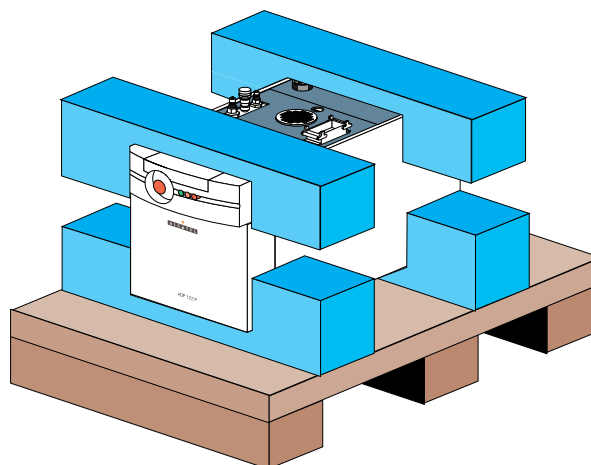

Unpacking / Storage

 For all equipment handling, use the devices provided for this purpose (lifting rings, handle, etc.).

Remove the pump from the crate

It is highly recommended to use a hoist.
Fit the pump with the hoisting rings.
Lift the pump using the rings and remove the foam blocks.

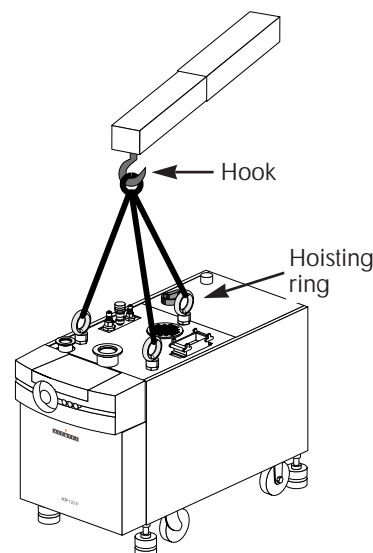

Pump	Weight in kg (lbs)
ADP 122	250 (551)
ADS 602	400 (881)
ADS 1202	550 (1212)

Prepare the pump

Screw in the leveling pads of the frame and lower the pump on the wheels.

Remove any additional packages from the crate and set aside. These packages will contain cables, accessories, and so forth.

To prevent humidity from entering the pump during transport, the unit has been pressurized with dry nitrogen before shipment. The inlet and exhaust are sealed with blank-off flanges which should not be removed until the pump is ready to be used.

Equipment storage

 If the pump is going to be put into storage, the inlet and exhaust, seals should be left in place.
Our equipment can be stored without particular storage precautions (pump pressurized in nitrogen and sealed) only at an ambient temperature between - 25°C and + 55°C.

Positioning the pump in the pumping installation

 Pump performance will depend on the kind of accessories used and the quality of the mechanical connections such as the pump fittings.

As these pumps are typically used in a corrosive atmosphere, their reliability will depend on proper installation and maintenance. When assembling the vacuum circuit, we recommend the installation of maintenance accessories such as shut-off valves on the inlet and purge lines.

For safety reasons, use accessories on the inlet and exhaust lines whose materials and sealing properties are compatible with the gases being used.

Positioning the pump

Determine where the pump will be placed.
Review to the dimensions according to the models before installation (see **A 40**).
Use a hoist to handle the pump, lifting it by the hoisting rings.

 The pump must be operated in the horizontal position, with the pumping axis vertical and the inlet opening upwards.

 Risk of tilting: Even when compliance with EEC safety rules is guaranteed (normal range $\pm 10^\circ$), it is recommended to take precautions to reduce the risk of tilting during product handling, installation and operation.

Each pump is equipped with four locking screw jacks. Lock the pump by adjusting these jacks so that all four feet are resting solidly on the floor.

See section **B 30** for installing anti-vibration pads.

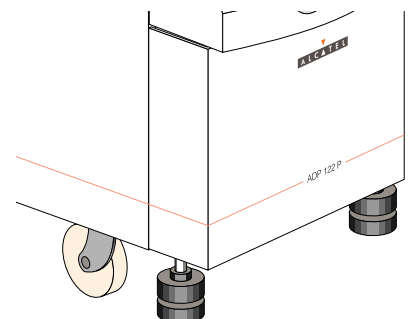

Positioning the pump in the pumping installation

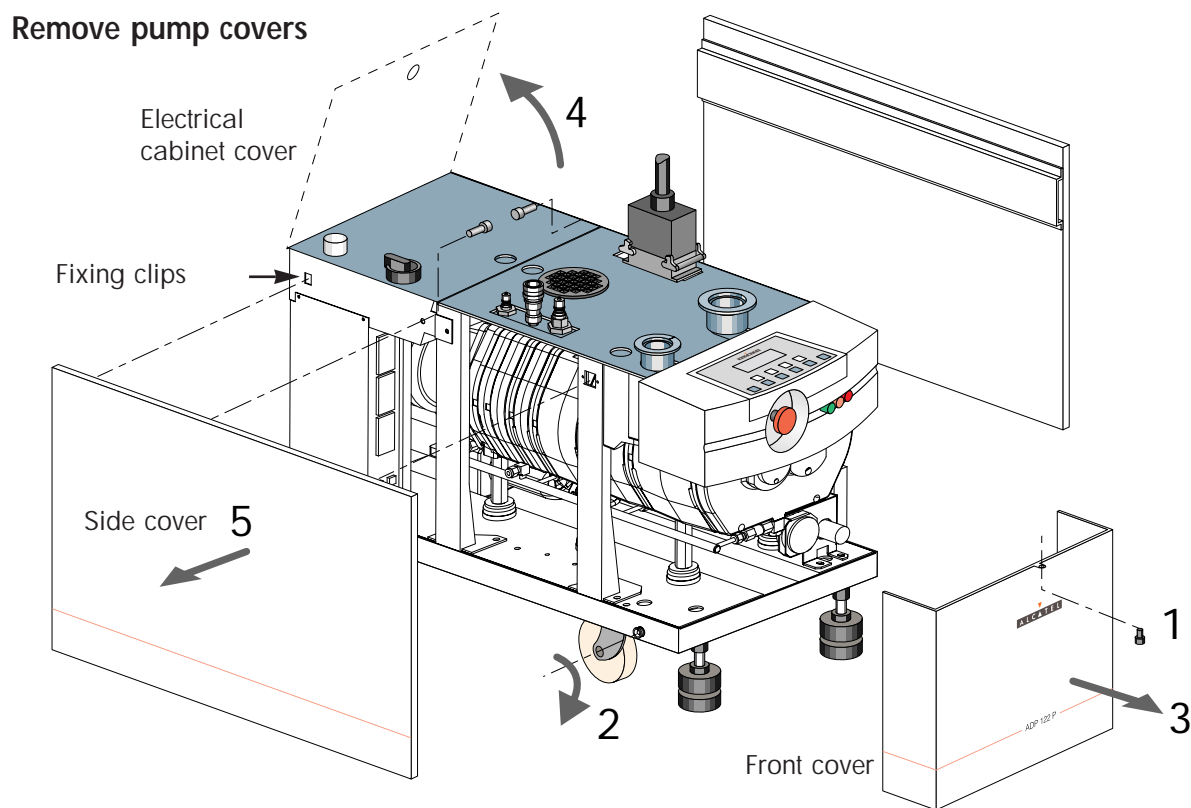

Remove the front cover fixing screw (1) and rotate the cover around its axes (2). Remove the front cover by pulling it outwards (3).

Note: make sure the circuit is electrically isolated

Remove the two side cover fixing screws, accessible by opening the electrical cabinet cover (4).

Pull (5) top part of the cover to remove the side cover out; then lift. Repeat the operation for the other side cover.

Installing anti-vibration pads (Accessories)

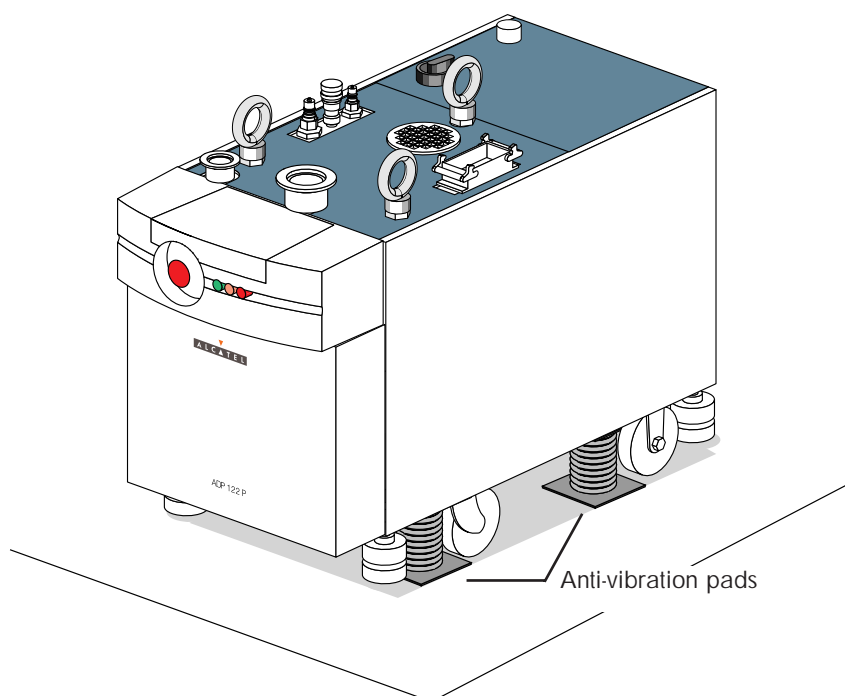

The pump can be equipped with anti-vibration pads which are mounted beneath the pump, near the locking feet.

Pads installation

Raise the pump using the 4 screws jacks.

Attach the 4 anti-vibration pads using the holes provided.

Lower the screw jacks so that the machine rests on the pads.

Characteristics

Vibrations transmitted to the ground by each support:

Quadratic mean acceleration:

< 10 mm/s² in the range 0.4 / 100 Hz,
< 200 mm/s² in the range 40 / 10000 Hz,

In order to limit the transmission of vibration to the foreline and the exhaust lines, it is recommended to use «flexible» connection accessories at the inlet and exhaust side (expanding type).

Filling the machine oil housings



Caution ! The pumps are delivered without an oil charge: the oil is found in separate containers. Similarly, it is recommended to drain the pump before returning the equipment.



For machines which use lubricants, it is recommended to request for the safety data sheets from the manufacturer.

The pump is tested using synthetic fluid Alcatel 113.

We recommend synthetic fluid Alcatel 113.



Mineral and synthetic oils cannot be used together. Contact Alcatel or your service agent before making any changes.

Oil quantities

OIL FILLING :

HOUSINGS :	ADP	REAR ROOTS HOUSING	FRONT ROOTS HOUSING	TOTAL CAPACITY	NBER OF CANS 0.4 L
ADP 122	0.35 L	-	-	0.35 L	x 1
ADS 602	0.35 L	0.45 L	0.25 L	1.05 L	x 3
ADS 1202	0.35 L	1.25 L	0.80 L	2.40 L	x 6

Filling the machine oil housings

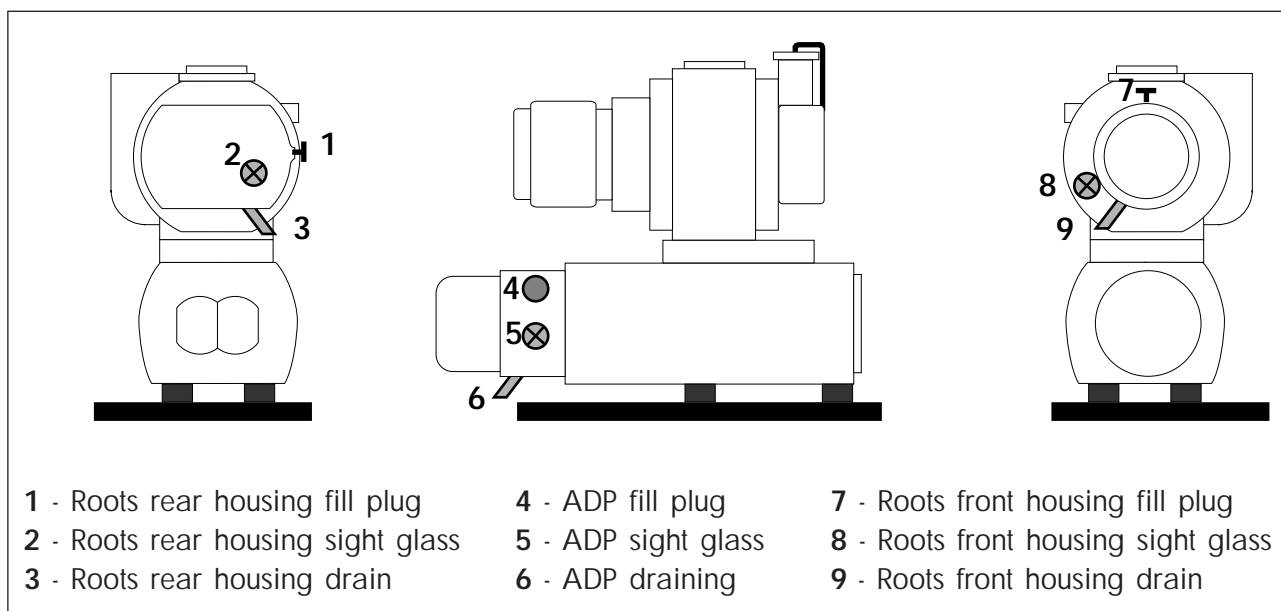

Filling procedure

Make sure the pump is off, and then remove the pump covers. Use the funnel equipped with a flexible tube delivered with the pump.

Filling of the Roots rear housing

Remove the fill plug (1). Position the funnel equipped with flexible tube in the oil filler neck. Fill the pump with oil according to the recommended quantities.

Do not exceed the indicated quantities.

The oil level should be in the middle of the sight glass (2). For this to be accurate, wait a few minutes for the oil to settle over all the internal surfaces. Replace the fill plug securely.

Filling of the Roots front housing

Remove the grid located on the top cover to access to the fill plug easier. Remove the fill plug (7). Position the funnel in the oil fill neck. Fill the pump with oil according to the recommended quantities.

Do not exceed the indicated quantities.

The oil level should be in the middle of the sight glass (8). For this to be accurate, wait a few minutes for the oil to settle over all internal surfaces. Replace the fill plug securely.

Filling the machine oil housings

Filling of ADP

Remove the fill plug (4).

Position the flexible tube in the oil fill neck.

Fill the pump with oil according to the recommended quantities.

The oil level should be in the middle of the sight glass (5).

Do not exceed the indicated quantities.

Replace the fill plug securely.

Connection to the cooling circuit

Water characteristics

In order to limit corrosion and fouling of the motor cooling coils, it is necessary to use cooling water with the following characteristics:

- Treated fresh water or non-aggressive industrial water
- pH between 7.5 and 11
- Hardness < 7 milli-equivalent/dm³
- Resistivity > 1500 Ω.cm
- Particles maximum size: 0.03 mm²
- Solid pollution < 100 mg/dm³
- Temperature from 10° to 25°C
- Pressure range between 3 and 7 bars absolutes
- Pressure Δ inlet/outlet: 2 bars minimum
- Flowrate per pump: 100 l/h

If the above mentioned characteristics are not respected, install a filter to the cooling connection.

Cooling circuit connections

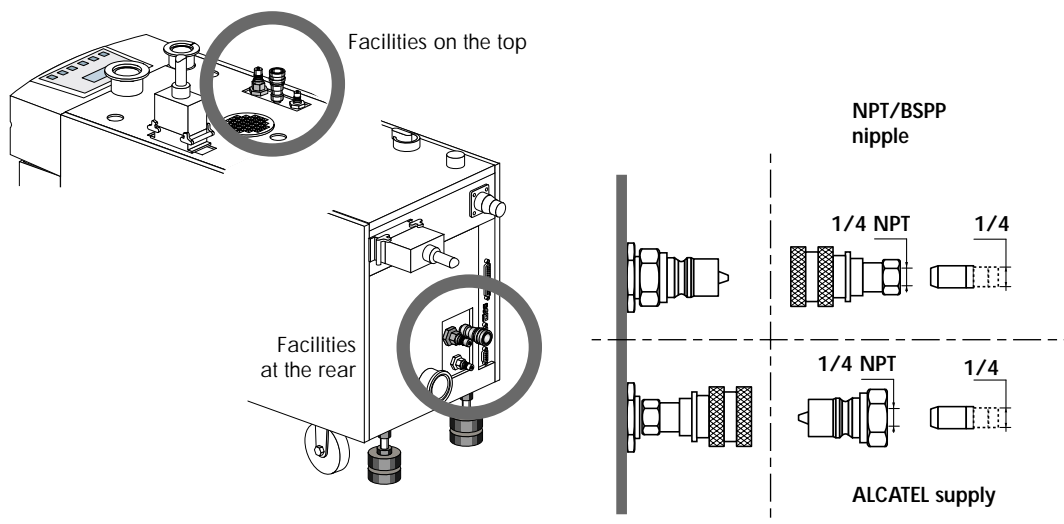

Install the two connectors, delivered separately, on the self-closing quick-couplings.

Attach the connectors to the supply and return lines:

- Water inlet labeled "IN" (1/4 NPT thread),
- Water outlet labeled "OUT" (1/4 NPT thread).

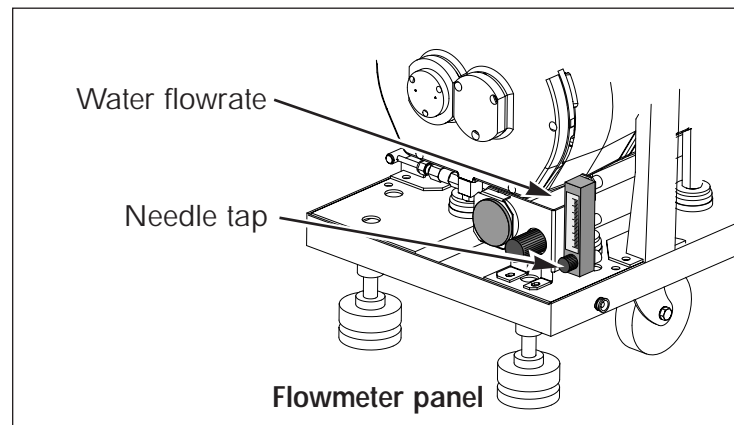
Connection to the cooling circuit**Water flowrate
adjustment**

Remove the front cover.

The water flow will be adjusted according to the pump model (see **C 60**) with the needle tap located on the flowmeter panel.

Inert gas purge connection (N2 plug)

Nitrogen characteristics ("P" version only)

For optimum performances the nitrogen supply should have the following characteristics:

- Maximum moisture rate: 5 ppm water
- Dust < 1µ.m
- Oil < 0.1 ppm
- Pressure between 3 and 7 bar absolute
- Flowrate per pump: 100 l/min.

 Before pressurizing the circuit, check that the pressure regulator is closed by turning the pressure regulator knob anti-clockwise (see B 60 2/2).

Connection

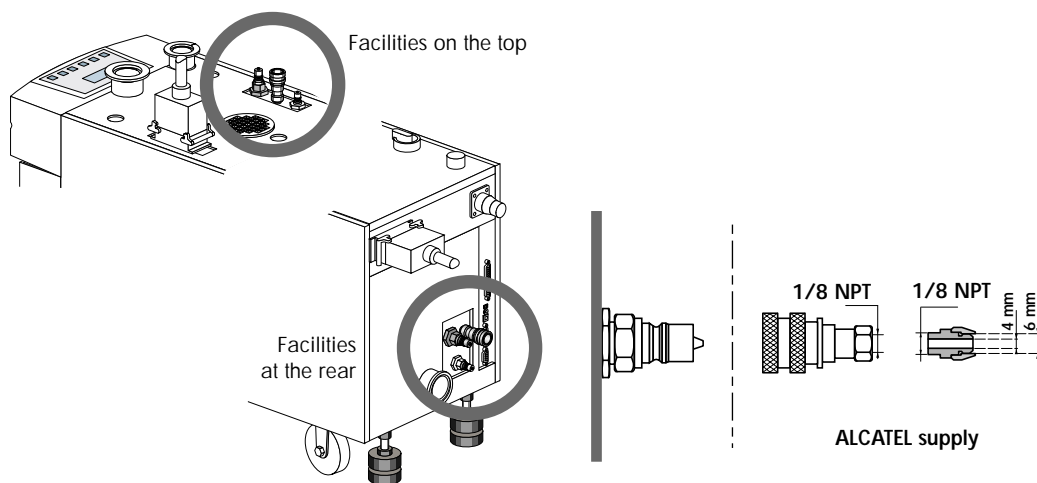

Inert gas purge connection (N2 plug)

N2 flowrate adjustment

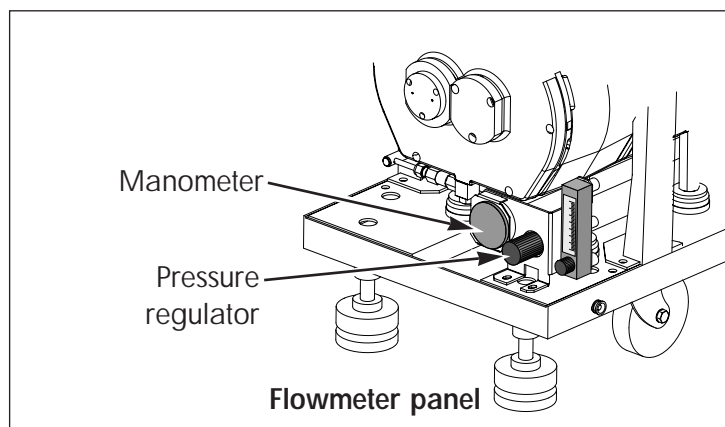

The N₂ flowrate will be adjusted with the pressure regulator according to the process (see C 60).

A mass flowmeter, located behind the front panel, allows flow reading on the hand-held remote control display.

Pump power supply



Study the preliminary precautions (see B 00)

All the electrical connections required for the various components operation have been done in the factory.

However, the user must make the electrical connection of the main power supply.

Customer electrical installation protection

Main circuit breaker rating (Minimum values)

Rating	BT	HT
ADP 122	15 A	10 A
ADS 602	25 A	20 A
ADS 1202	30 A	25 A

Minimum cut off rating of main pump switch: 10 kA.

For any change of power supply voltage in relation to the initial configuration, contact Alcatel Customer Service.

Electrical connection using a connector

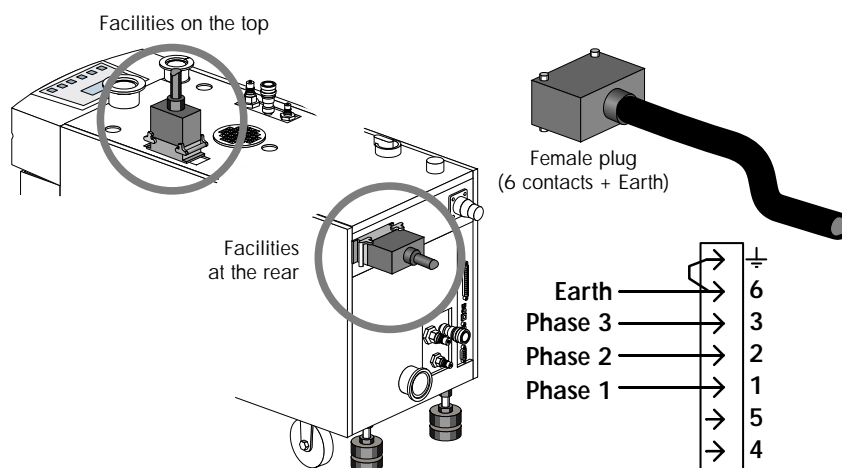

The pump is supplied with a female plug delivered separately. Connect the mains cable to the power supply connector using wires with the following specifications:

- AWG-12 (2.5 mm²) per ADP 122
- AWG-10 (4 mm²) per ADS 602/ADS 1202.



Check that the cable is correctly protected against ground defects and that earth wire is longer than the three conducting wires.

Then, connect the connector on the pump frame **and lock it**.

Pump power supply

Electrical hard wired connection (required for SEMI compatibility)

Open the electrical cabinet. Pass the cable through one of the feedthrough provided for this purpose.

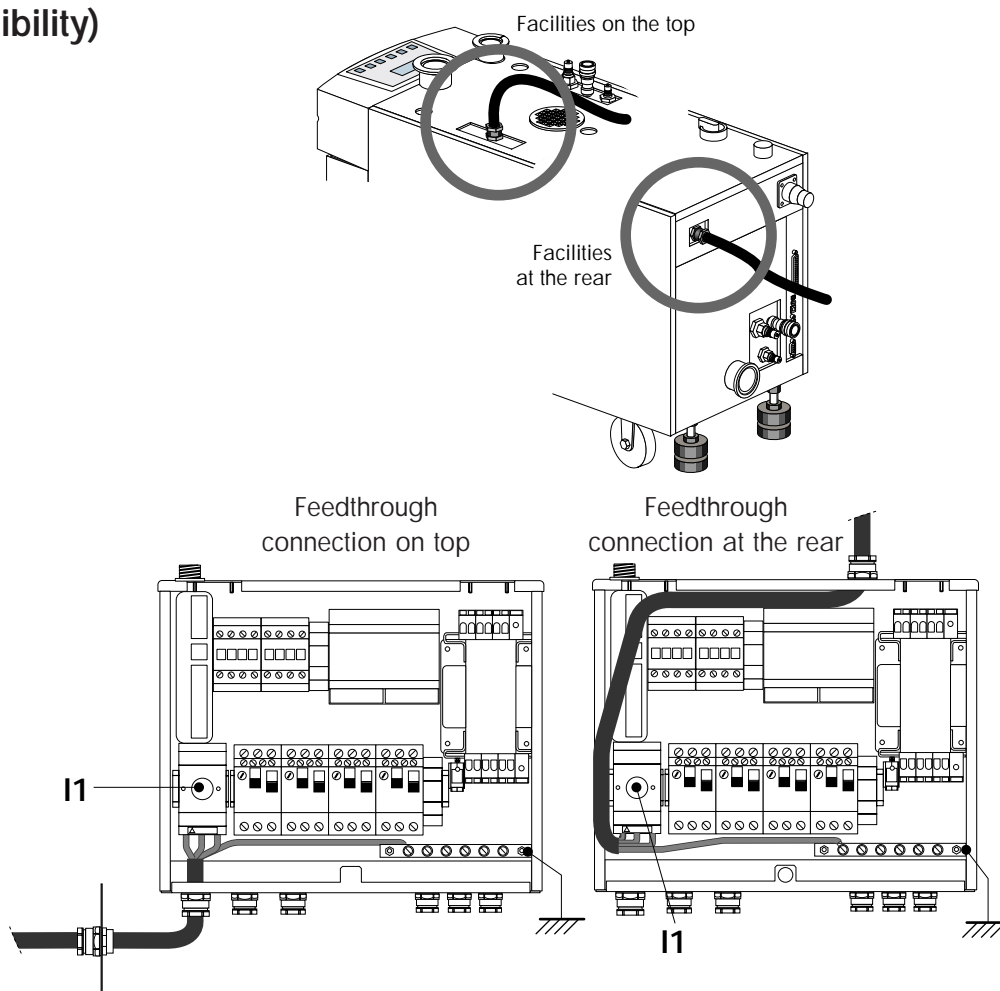

Connect the mains cable to the I1 main disconnect switch using a cable with following specifications:

- AWG-12 (2.5 mm²) per ADP 122, or
 - AWG-10 (4 mm²) per ADS 602/ADS 1202.
- (cable customer supply)

Connect the ground to the separate terminal bar.



Check that the cable is correctly protected against ground defects and that earth wire is longer than the three conducting wires.



Check the direction of rotation of the pump at the first start-up (see B 90).

Checking the direction of rotation and initial pump start-up



Study the preliminary precautions (see B 00)



- Before using the monitoring, check that the mechanical and electrical connections defined in the chapter B have been made.
- Before each pump starts-up, check that oil levels of ADP and Roots housings are visible in the middle of the sight glass: do this check with the pump stopped.
- In order to prevent moisture from entering the pump before installation, it has been pressurized before hand with nitrogen and sealed with blank-off flanges.
- Remove the guards blocking the intake and exhaust holes; these components prevent foreign bodies from entering the pump during transport and storage. It is dangerous to leave them on a pump in operation.

Connect the cover plugs



In local mode, the pump will run only if the cover plugs (delivered with the pump) are respectively connected on J1 and J14 connectors (remote control connector).

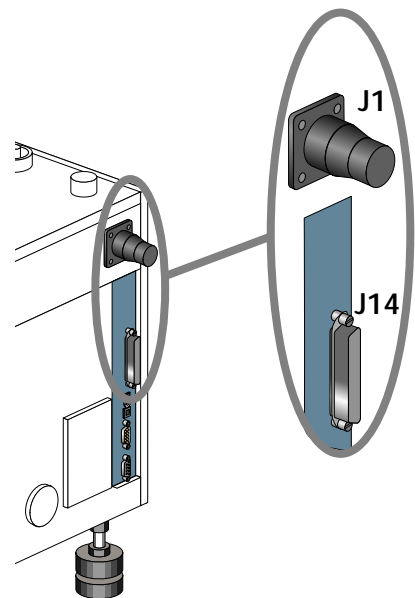

Checking the direction of rotation and initial pump start-up

Switch on the pump

Set the main switch to position 1.
The "mains on" indicator light comes on.

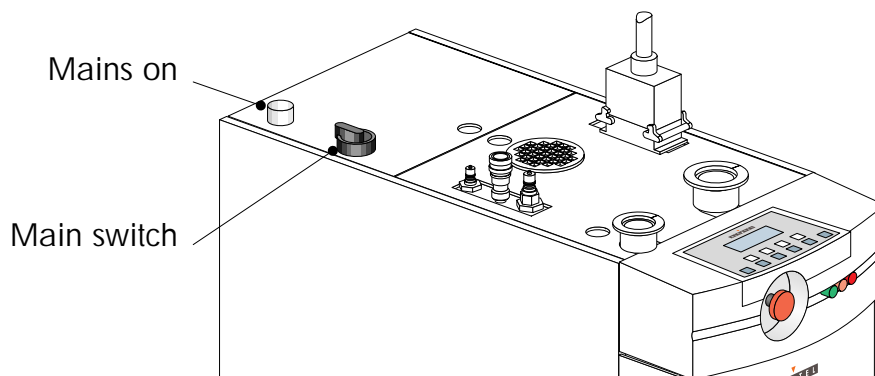

Controlling the pump using the hand-held remote control

The hand-held remote control allows to control the pump and to configure the parameters.

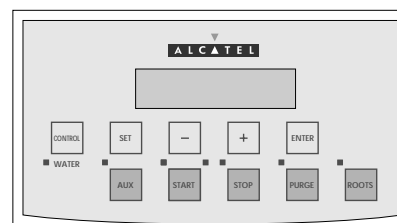

At the first hand-held remote control connection, the monitoring identifies the pump.

```
ALCATEL          AVT-F
MONITORING XXXXXX
PRESS ENTER
FOR COMMUNICATION
```

Initialize the system by pressing on ENTER.

```
1H LOC          ROOTS
PUMPING STOPPED
13/10/98          15:39
```

Because it is the first connection, it is necessary to take the pump control via the CONTROL key: a star appears on the left side of the display.

```
* 1H LOC          ROOTS
PUMPING STOPPED
13/10/98          15:39
```

Checking the direction of rotation and initial pump start-up

Check the direction of rotation at initial pump start-up



When inspecting the direction of rotation of the Roots at the initial start-up, provide protection against the risk of compression related to the rotating parts in the inlet. **Caution ! A non-powered Roots can be driven by another pump in rotation (risk of compression) .**

Remove the blank-off flange on the inlet and exhaust port.

Fit a pressure gauge at the pump inlet.

Set the main switch to position **1**.

Press on the **ROOTS** key until the word **ROOTS** disappears from the display.

Start-up the pump by pressing "**START**" (on "**ON**" for an ADP 122 L) and stop it after few seconds:

- if the pressure indicated is less than $5 \cdot 10^{-1}$ mbar, the direction of rotation is correct.
- if the pressure increases, **invert two phases at the main power input female connector, or from main switch terminal** (if connection on feedthrough - *see B 70*).



Before any service on the electrical cabinet, make sure the electrical source has been disconnected to the pump (customer mains circuit switch).

Note : Rotation can also be checked at the exhaust by making sure gas is being forced out at the exhaust nipple.





In order to prevent foreign bodies from entering the pump, while waiting to be installed, replace blank-off flanges on inlet and exhaust ports again.

As soon as the installation and start-up procedure is complete, and the direction of rotation is checked, (*sheets B 10 to B 80*), the pump is now ready for use (*see B 90*).

However, if the pump has to be remote controlled, proceed to specific wiring instructions (*B 100*).

Connection to the pumping circuit

 Remove the guards blocking the intake and exhaust holes; these components prevents foreign bodies from entering the pump during transport and storage. It is dangerous to leave them on a pump in operation.

 The vacuum pump is also a compressor: incorrect use may be dangerous. Study the user manual before starting the pump

Make sure the direction of rotation has been checked (see B 80).

At the pump exhaust

Preliminary precautions

 Any maintenance accessories connected to vacuum circuit should be done at this time (inlet and exhaust isolation valves, purges, ...)
It is recommended the pump exhaust be connected to an flue gas evacuation pipe.

For safety reasons, any accessories connected to the inlet and exhaust must be made of materials compatible with pumped gases and the leak test after the reassembly is completed.

Anti-noise device

For free exhaust test (neutral gas pumping, air), an anti-noise device supplied with the pump can be fitted on to the exhaust tube in order to reduce the exhaust noise level.

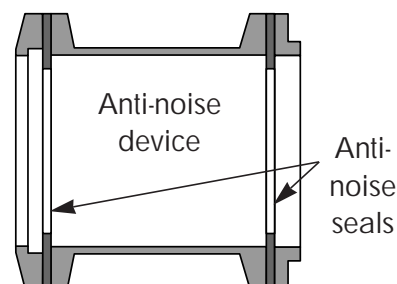

 When pumping on aggressive gases, the exhaust of the pump must be connected to an exhaust stack or an evacuation duct. In this case, do not use the anti-noise device.

Make sure that the exhaust pressure does not exceed 1200 mbar.

Exhaust connection

DN40 ISO KF. Several fitting accessories are available in the Alcatel catalog.

Connection to the pumping circuit

At inlet pump



Make sure that any vacuum accessories connected to the inlet of the pump can withstand a negative pressure of 1 bar with reference to the atmospheric pressure.

Inlet isolation valve
(accessory)

This accessory avoids a sudden reverse flow of gas to the chamber when the pump is stopped.

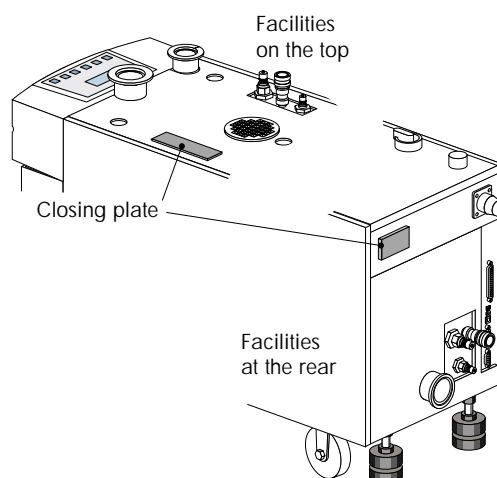

Connect the valve directly on the pump inlet flange using connecting accessories.

Connect the electrical cable to the electronic cabinet inside the frame (**see D 10**).

If the valve must be remote controlled **see B 100**.

Remove the closing plate, connect the cable to the electronic cabinet and the plate equipped with a feedthrough, delivered with the cable.

Exhaustable enclosure
(required for
SEMI compatibility)

The enclosures have to be exhausted with a volumetric flow rate of minimum 67 CFM, with a duct static pressure of 0.04" w.g.(as measured 2.0' from the duct connection to the cabinet). The size of the exhaust duct is 4", the material can be PVC, except for flammable gases for which stainless steel is strongly advised.

J 14 remote control plug connection



Study the preliminary precautions (see B 00)



When units containing control circuits are equipped with dry contact outputs, it is the responsibility of the customer to use these outputs in compliance with safety standards.

The remote control function allows:

- Remote control of pumping functions "START/STOP/PURGE", "Roots" and "Inlet valve".
- Remote monitoring of parameters through auxiliary dry contacts (50V - 1A). These contacts can be used to control automatic functions.

Location of J 14 remote control connector

The remote control connection is done via the "J 14" connector, located on the rear panel of pump.

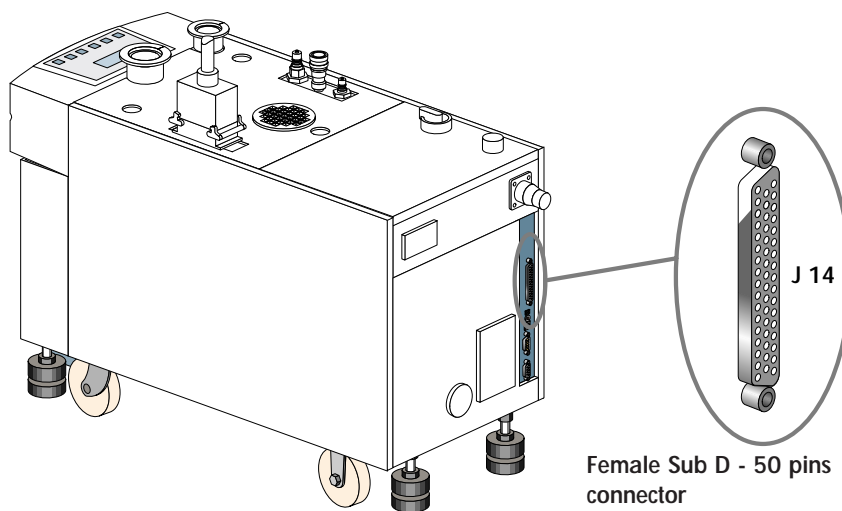

In local mode, the pump can run only if the cover plug (delivered with the pump) is fitted on "J 14" connector.

J 14 remote control plug connection

Cover plug wiring

Cover plug type: Sub D - 50 pins connector.

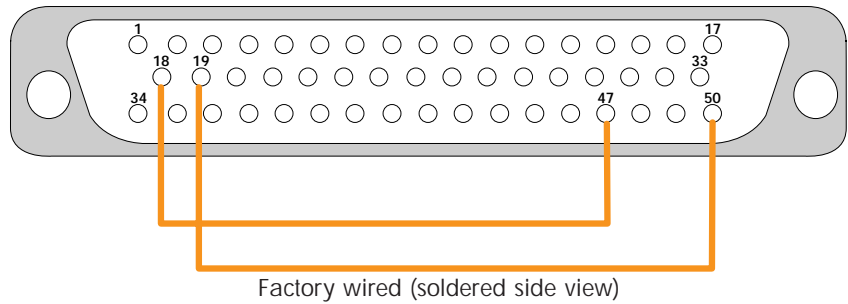

Control contacts (inputs)

These inputs are considered to be activated when a DC voltage between 5 and 30V is applied.

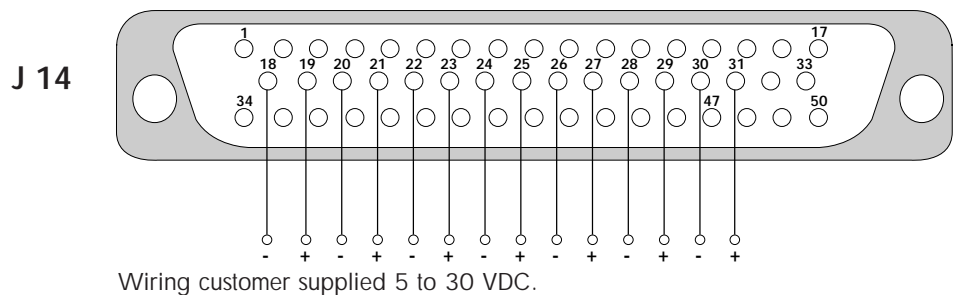

Inputs can be used by pins 47, 48 (0V) and pins 49, 50 (12V), in order to be controlled by external contacts of the customer equipment.

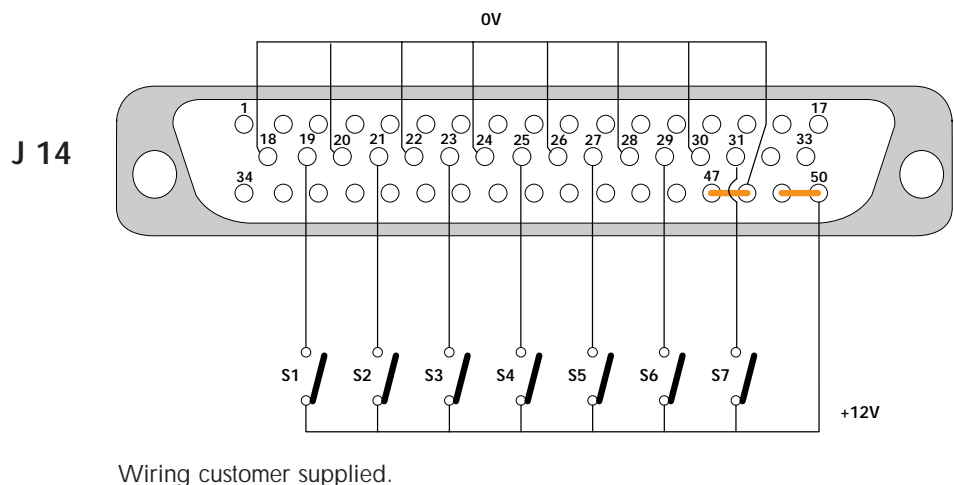

J 14 remote control plug connection

Control contacts (inputs) (continued)

Contact	Function
S1	Contact open, remote control valid, keyboard inhibited Contact closed, keyboard valid, remote control inhibited
S2	ADP Start/Stop
S3	Roots Start/Stop if "Roots CMD" selection is validated in DEFINITION menu
S4	N2 purge Start/Stop if "Purge CMD" selection is validated in DEFINITION menu
S5	Switching command "Stand Purge" if the "N2 standby" selection is validated in DEFINITION menu
S6	Opening/Closing of inlet valve if S7 is activated
S7	Authorization to close or not the inlet valve if INLET VALVE OPTION is validated in DEFINITION menu

Available outputs

Available dry contacts 50V - 1A.

Contact	Function
	These contacts open in the presence of a fault:
14-15	Pump operation (ADP or ADS)
16-17	State of inlet valve
8-9	Pump running, correct purge and valve opened
6-7	Maintenance alert
39-40	Exhaust pressure alert
37-38	Purge alert
35-36	Motor temperature alert
1-34	Pump fail (pump running, valve opened, no alert)
2-3	Alert presence
4-5	Alarm presence - Unit stoppage
	These contacts close in the presence of a defect:
12-13	Alert presence (without maintenance)
10-11	Alarm presence - Unit stoppage

J 3 remote control plug connection (ADP 122 L)



Study the preliminary precautions (see B 00)



When units containing control circuits are equipped with dry contact outputs, it is the responsibility of the customer to use these outputs in compliance with safety standards.

The remote control function allows:

- Remote control of pumping functions "START/STOP/PURGE", "Roots" and "Inlet valve".
- Remote monitoring of parameters through auxiliary dry contacts (50V - 1A). These contacts can be used to control automatic functions.

Location of J 3 remote control connector

The remote control connection is done via the "J 3" connector, located on the rear panel of pump.

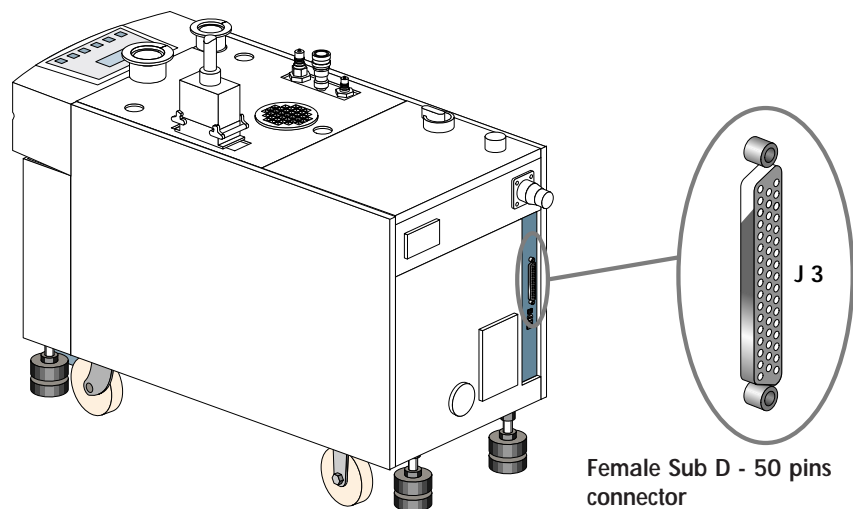

In local mode, the pump can run only if the cover plug (delivered with the pump) is fitted on "J 3" connector.

J 3 remote control plug connection (ADP 122 L)

Cover plug wiring

Cover plug type: Sub D - 50 pins connector.

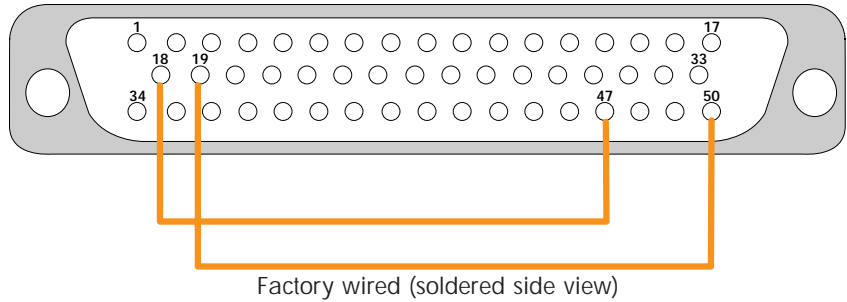

Control contacts (inputs)

J 3

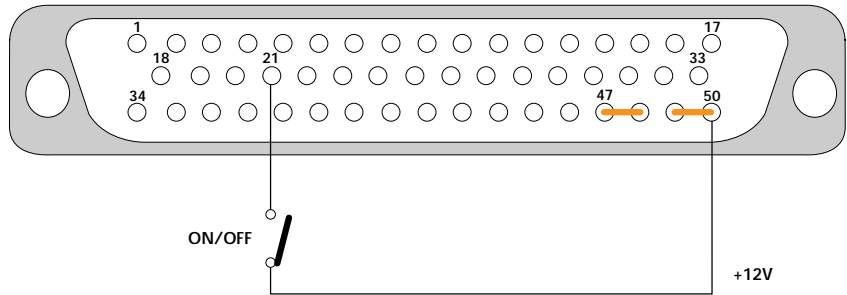

Inputs can be used by pins 46 (0V) and pins 45 (+24V).

J 3

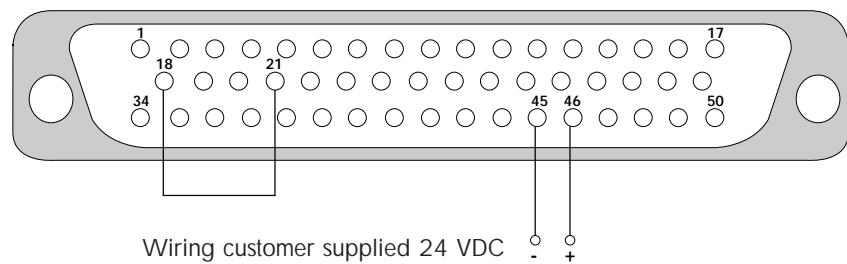

Available outputs

Available dry contacts 50V - 1A.

Contact	Function
	These contacts open in the presence of a fault:
14-15	Pump operation (ADP)
8-9	Pump running, valve opened, no alert
1-34	
2-3	Alert presence
4-5	Alarm presence - Unit stoppage

Emergency stop plug connection

"J1" connector location This connector allows the control or remoting of the emergency stop function from the front panel of the unit.

This connector is located at the rear of the pump.

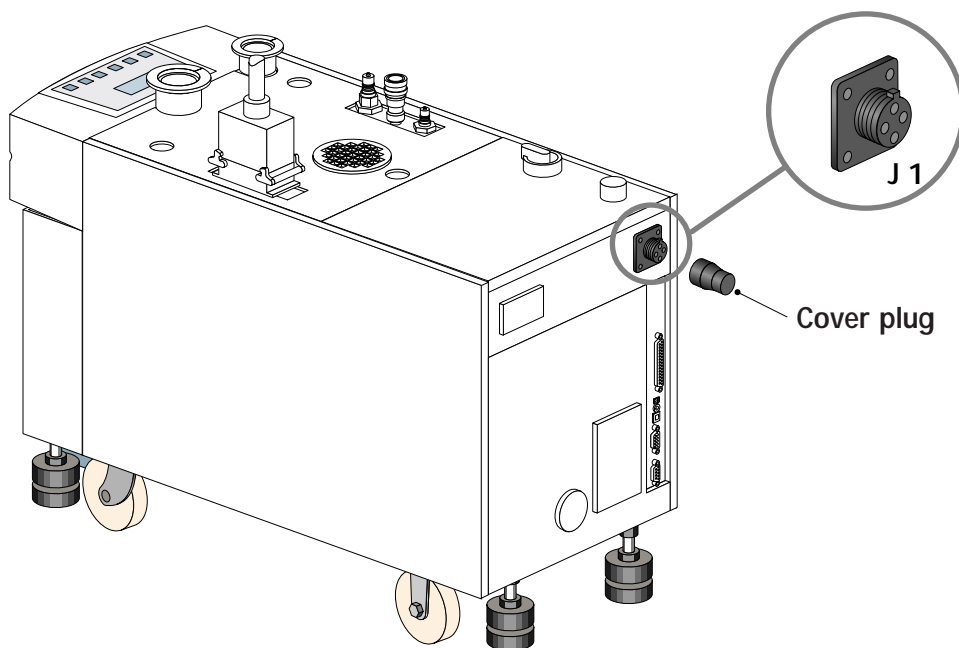

Cover plug wiring

 In local mode, the pump can run only if the cover plug (delivered with the pump) is fitted on "J1" connector.

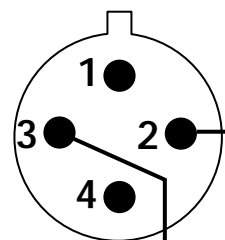

AMP connector
Wiring viewed under soldered side

Emergency stop plug connection

Control contact (input)

The input is considered activated when the pins are linked.

Contact	Function
2-3	Contact opened, emergency stop command is activated.

Available output: "Emergency stop" state

It is a dry contact.

Contact	Function
1-4	This contact opens when emergency stop is activated: Contact opened, emergency stop command is activated.

RS 232 or RS 485 link wiring

At the first power-on, the user will find the initial configuration set at factory.

The settings can be modified through the M4 corresponding menu.

The initial configuration of the serial link is as follows:

- Type : **RS 232**
- Transmission SPEED : **9600 bauds**
- Data Length : **8 bits**
- Parity : **NONE**
- Stop bit : **1**

Connector wiring RS 232/485 (J6)

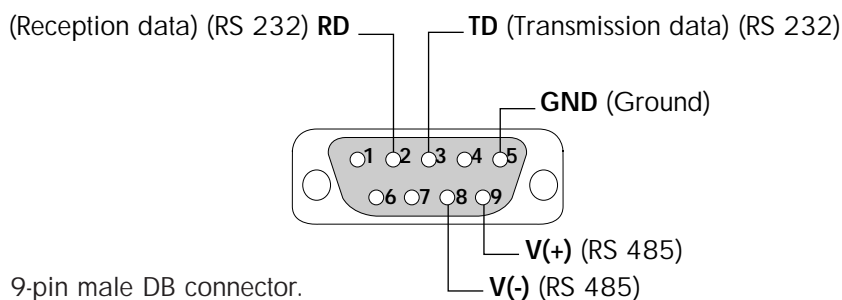

Connector wiring RS 485 (J7)

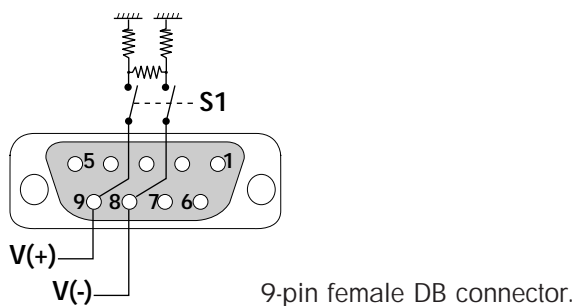

RS 232 or RS 485 link wiring

The commands and messages reception syntax is dealt with in a separate chapter (**Contact Alcatel**).

Examples of possible connection

Link RS232
with a single
monitoring system M4



Multiple serial link RS 232

Several M4 monitoring systems may be connected on a single link.

The multiple link is obtained by creating a loop and validating "Echo" function:

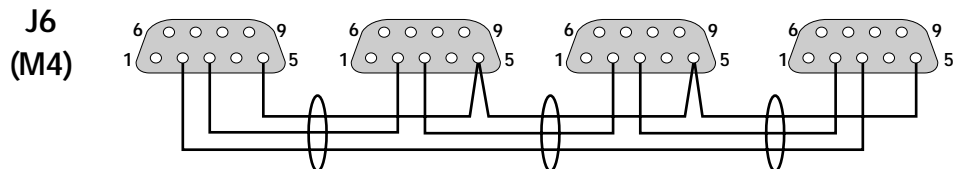

Serial link RS 485

Link using standard cables, which will be interrupt at monitoring disconnection.

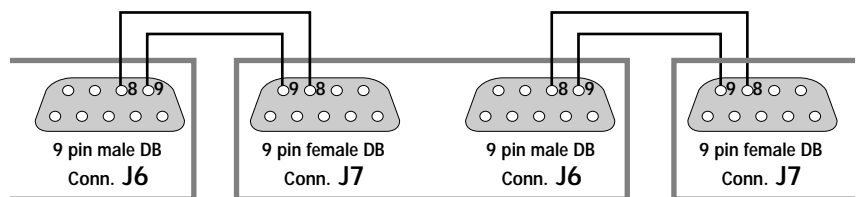

Link using specific cables, without interruption at monitoring disconnection.

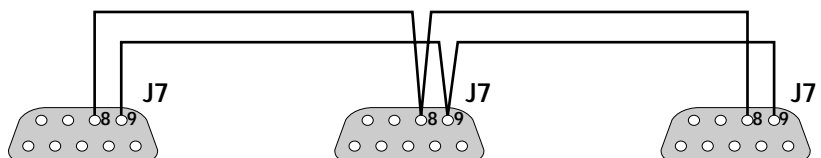

In both cases, for the units located at end of link, **S1** must be to "ON" position.

User's Manual
ADP/ADS Series Two

Operation

- Operating modes (P model pumps) ■ C 10
- Operating modes (L model pumps) ■ C 11
- Start-up of the M4 monitoring system ■ C 20
- Use of the M4 monitoring system for pumping operation ■ C 30
- Use of the pump ADP 122 L ■ C 31
- The M4 monitoring system parameters ■ C 40
- M4 monitoring system function table. ■ C 50
- Water flowrate and gas purge according to main semiconductor processes ■ C 60
- Saving and remote loading of pump configuration (with M4). ■ C 70
- M4 monitoring setting for transport. ■ C 80

Edition 02 - February 99

Operating modes (P model pumps)

Different control modes

According to the monitoring configuration and wiring, the pump can be:

- locally controlled by the hand-held remote control,
- remote controlled by serial link,
- remote controlled using dry contacts via J 14 connector.

Local mode



In local mode, the cover plugs delivered with the machine must be plugged on J1 and J 14 connectors.

In this case of operation, the pump is running as a stand-alone part of the equipment on which it has been installed. The pump is controlled by a hand-held remote control, connected in front or at the rear of the frame, or by both simultaneously connected, one in front, the other at the rear of the frame.

A second hand-held remote control can also be connected in series with the first one.



For safety reasons, the pump can be controlled only by one hand-held remote control at the same time.

Switch configuration according to the hand-held remote control layout

Two switches have to be configured: the first at the back of hand-held remote control and the second, S1, located on electrical interface (see A 20).

Use of only one hand-held remote control:

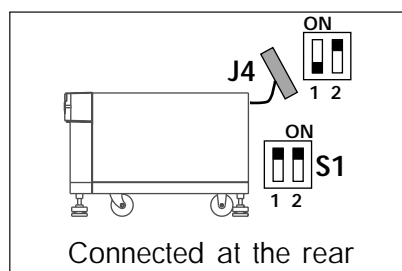
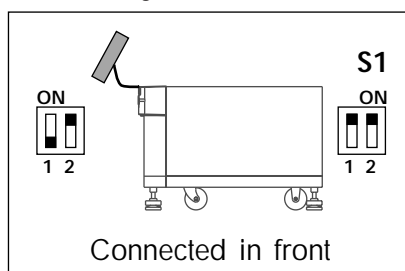

Use of two hand-held remote control:

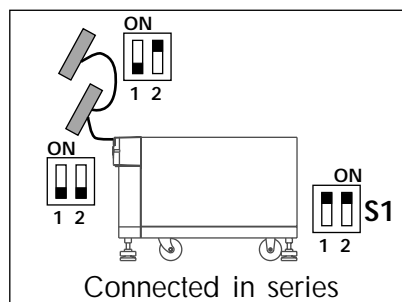
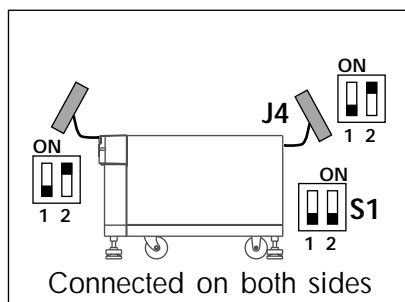

Operating modes (P model pumps)

Remote controlled operating modes

Remote control via J 14 (Dry contacts) Pump alone

The pump is monitored by the equipment in which it is installed (such as an automated pumping system or of an industrial equipment).

The pump is remote controlled by the opening or closing of different dry contacts wired on J 14 connector (*see B 100*).

The hand-held remote control keyboard is inhibited as long as the contact S1 of the J 14 connector (*see B 100*) is kept open. In Remote mode, "RM" is displayed on the display.

Datas and operating parameters can be read locally on the hand-held remote control.



The control of emergency stop is not possible from J 14 connector: use the J1 connector "EMERGENCY STOP" located at the rear of the pump if emergency stop must be remote controlled (*see B 110*).

Remote control via RS 232/485 serial link Pump alone or in a group of pumps

The pump is monitored by the equipment in which it is installed, either alone or in a group of pumps.

It is remote controlled by the commands transmitted on the serial link (*see B 120*).

Commands and messages reception syntaxes are given in a separate chapter. Consult Alcatel.

The remote mode dry contacts have the priority on the serial link mode.

Operating modes

ADP 122 L

Different control modes

According to the monitoring configuration and wiring, the pump can be:

- locally controlled by the control box,
- remote controlled using dry contacts via J 3 connector.

Local mode



In local mode, the cover plugs delivered with the machine must be plugged on J 1 and J 3 connectors.

In this case of operation, the pump is running as a stand-alone part of the equipment on which it has been installed.

The pump is controlled by a control box, which includes the ON/OFF switch and the time counter (Counting the pump operating time).

Remote controlled operating mode

The pump is monitored by the equipment in which it is installed. The pump is remote controlled by the opening or closing of different dry contacts wired on J 3 connector.



The control of emergency stop is not possible from J 3 connector: use the J 1 connector "EMERGENCY STOP" located at the rear of the pump if emergency stop must be remote controlled (see B 110).

Operating modes

ADP 122 L

Operation monitoring from M4 monitoring system

The ADP 122 L pump can be connected to the M4 monitoring system of another pump which is monitoring, on the logic inputs, information related to the "Load Lock" pump operation.

Following functions are monitored :

- the state "Running" (ON/OFF);
- the state defect (Temperature alert);
- Operating time (for maintenance).

For that, the ADP 122 L pump must be connected to another pump equipped with an M4 monitoring system and the following parameters have to be configured :

- **LL PUMP OPTION**
- **LL MAINT.** (Operating time of ADP 122 L);
- **LL MAINT. ALERT** (Maintenance threshold).

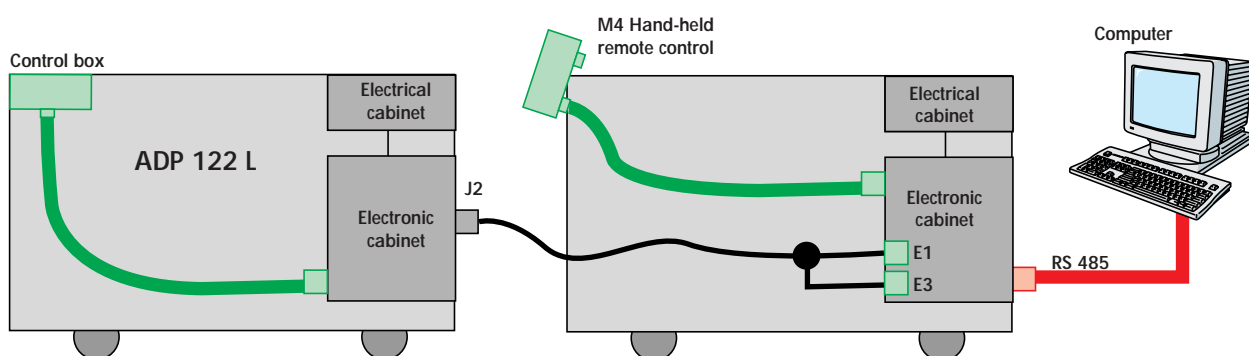

Start-up of the M4 monitoring system



Study the preliminary precautions (see B 00)

The hand-held remote control

It is used to control the pump and configure the parameters.

Parameter selection and configuration keys

Indicators

Manual control key

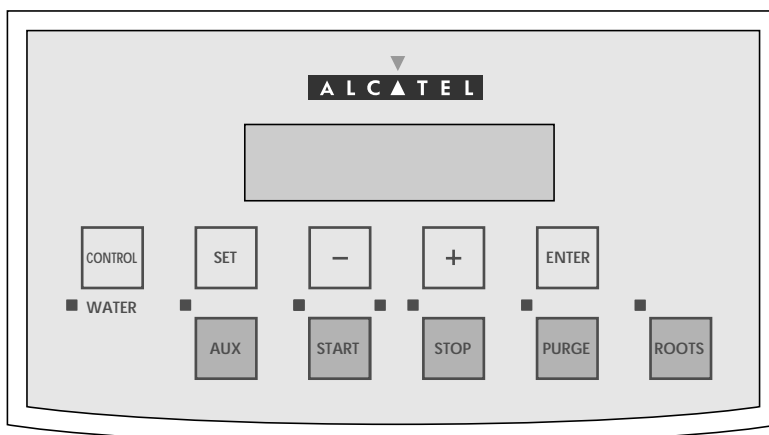

The functions of the parameter selection and configuration keys

Symbol	Description	Functions
	Parameter setting mode access key	<ul style="list-style-type: none"> Used to gain access to the parameter setting mode Used to exit the various menus without validating the functions
 	Selection keys	<ul style="list-style-type: none"> Used to gain access to: <ul style="list-style-type: none"> the next or previous menu the next or previous parameter in the displayed menu Used to select or adjust the value of the parameter selected previously
	Configuration validation key	<ul style="list-style-type: none"> Used to validate the selection of a menu, parameter or value Used to confirm an answer to a question



An insulating film protects the keys. Do not use hard objects such as pens, screwdrivers, etc., which could damage the keys.

The continuous pushing of + and - keys allows for quick scrolling. Use by successive pulses for the other keys.

Start-up of the M4 monitoring system

Pump start-up

Put the main switch on position 1.
The "mains on" light indicator comes on.

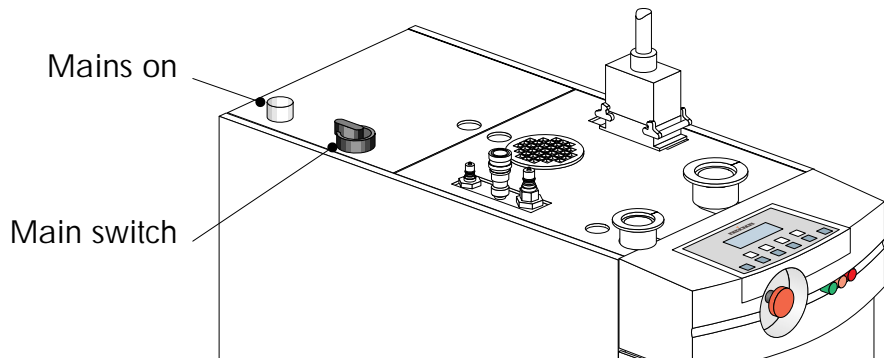

The monitoring displays the state of the pump. The star appears on the left side of the display and indicates that the control has been taken by hand-held remote control (Control taken to check the direction of rotation).

```
* 1H LOC      ROOTS
PUMPING STOPPED
01/23/99      15:39
```

The M4 monitoring system has been configured in the factory according to the options and accessories defined during the order.

This configuration allows the pump to run (*see C 30*). If parameters have to be customized by the user, it is necessary to gain access to the program.

Accessing the programmable parameters

The programming made at the factory is protected by an access code which disables the entry of new parameters.

Press the key SET.

Valid the code with ENTER.

Access code and parameters can be customized (*see C 50*).

```
ENTER PASSWORD :
```

```
CODE : 0
```

Start-up of the M4 monitoring system

To ensure correct maintenance schedules, monitoring of the faults and customized parameters, it is necessary to initialize time and date of the machine.

Reset the clock (at the initial start-up)

Enter in the menu by **SET**.
Go on using **+** to access to the **SETTING** menu and valid by **ENTER**.

```
DEFINITION
>>> SETTING <<<
MAINTENANCE
MANAGEMENT
```

Go on using **+** to access to the **DATE/TIME** menu and valid by **ENTER**.

```
SERIEAL LINK
>>> DATE/TIME<<<
TEMPERATURE UNIT
PRESSURE UNIT
```

Select the parameters to be modified and set them using **+** and **-** key.
Valid by **ENTER**.

```
DAY
MONTH
YEAR
HOUR
```

Return to the main menu and exit the setting mode using the key **SET**.

Use of the M4 monitoring system for pumping operation



Study the safety instructions (see B 00).



Check the direction of rotation at the initial start-up (see B 80).



The performances and the operational safety of this product are guaranteed provided that it is used in normal operating conditions.

Operation setting

According to the operating mode chosen, check the position of the switches (S1 on electrical interface, and at rear of hand-held remote control) (see C 10).

Neutral gas purge control

To ensure the gas purge comes on as soon as the pump starts, set the **CMD PURGE** menu on **INVALID**.

To start-up or stop the gas purge during pumping, set the **CMD Purge** menu on **VALID**.

The purge will start or stop by pressing the **PURGE** key.

Pump start-up

To start the Roots and ADP simultaneously, set the **CMD. ROOTS** menu on **INVALID**.

To start-up or stop the Roots while the ADP is running, set the **CMD. ROOTS** menu on **VALID**.

The pumps will start or stop by pressing the **ROOTS** key.

Use of the M4 monitoring system for pumping operation

Pumping start-up Start-up the pumping by pressing **START**.

The monitoring system performs the following operations:

- opening the inlet valve (if preselection has been validated),
- ADP pump start-up,
- opening the water valve,
- data capture and sensor processing,
- opening the purge gas valve (if preselected),
- Roots pump start-up (if preselected).

At the same time the operating parameters are shown.

52H LOC N2	ROOTS
ADP POWER	1410 W
PRESSURE	940 MBAR
ADP TEMP.	58°C

Gain access to other operating parameters* using the **SET** key (see C 50).

(*) Only installed and configured options parameters are displayed.



The pumps are equipped with an exhaust pressure monitoring sensor. When this is not used (particularly L version), it is the responsibility of the user to prevent the risks related to excess overpressure.



Avoid moving a pump in operation

Operation monitoring

During operation, the user is warned of an operating incident by:

- one or more faults are displayed on the screen, alternating with monitoring parameters. When these faults are activated, the monitoring system triggers the alert phase followed by the alarm phase. The period for these phases are programmable.
- indicator light and buzzer sounded, if option selected.
- indicator light on display panel.
- the fault contacts on the remote connector J14 at the rear of the monitoring unit are closed.
- pumping is stopped.

A list of incidents is given in the **chapter D**.

Use of the M4 monitoring system for pumping operation

Pumping shut-down Press on **STOP** key.

The monitoring system performs the following operations:

- inlet valve closing (if the pump is fitted with such accessory and if option selected).
- pump stopping,
- water valve closing,
- injection of purge gas is continued during the shutdown phase (if programmed),

When the stoppage is caused by a loss of power, automatic restarting is possible if **AUTO RESTART** is set on **VALID**.



When the pump has been configured for automatic restart after a power failure, it is the responsibility of the user to take all the measures required to prevent risks resulting from this type of operation.

Use of the M4 monitoring system for pumping operation

Use with two hand-held remote controls

To take the control with a hand-held remote control, press only on the **CONTROL** key of the choosen hand-held remote control: then a star appears on the left corner of the display.

The control of the pump is now not possible from the other hand-held remote controls, as long as the first one has not given the control back.

To give the control again, press on the **CONTROL** key of the hand-held remote control, until the star has disappeared.

Reading of data and parameters can be done on both hand-held remote controls, **even if they do not control the pump.**



If the message "NOT ALLOWED" appears after an action of any key, check the presence of the star on the display, showing that the control has been taken.

Use of the pump ADP 122 L



Study the safety instructions (see B 00).



Check the direction of rotation of the pump, at initial start-up (see B 80).



The performances and the operational safety of this product are guaranteed provided that it is used in normal operating conditions.

Pumping start-up

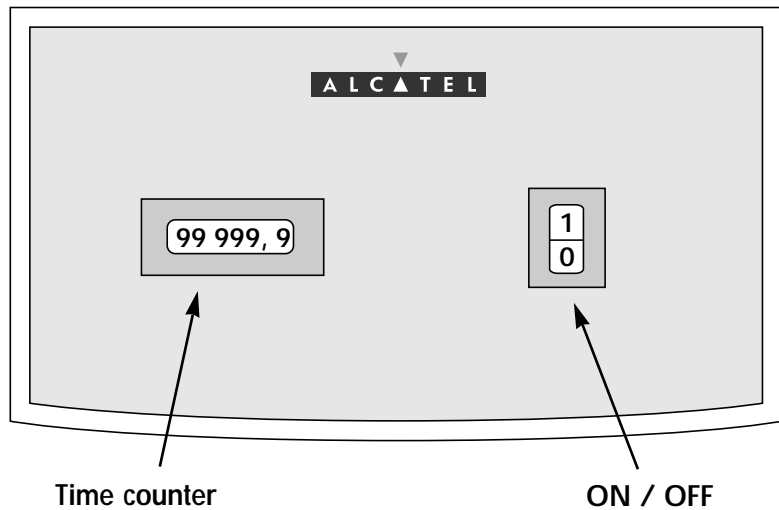

Put the **ON/OFF** switch on position 1 to start the pump.

The monitoring system performs the following operations:

- ADP pump start-up,
- opening the water valve,
- data capture and sensor processing,
- the time counter increases.



Avoid moving a pump in operation

Use of the pump ADP 122 L

Operation monitoring

During operation, the user is warned of an operating incident by:

- indicators light on display panel.
- the fault contacts on the remote connector J3 at the rear of the monitoring unit are closed.
- pumping is stopped.

Pump shut-down

Put the **ON/OFF** switch on position 0.

The monitoring system performs the following operations:

- pump stopping,
- water valve closing.

When the stoppage is caused by a loss of power, restart is automatic after power returns.



When the pump has been configured for automatic restart after a power failure, it is the responsibility of the user to take all the measures required to prevent risks resulting from this type of operation.

The M4 monitoring system parameters

Purpose of the sensors

Mass-flowmeter	<p>Allows the display of the nitrogen flowrate</p> <p>Signals insufficient gas purge during a warning time, and stops the pumping at the end of alarm time.</p>
Temperature sensor	<p>Allows the regulation of the ADP temperature.</p> <p>Signals a pump temperature variation (alert if $T >$ alert threshold and alarm if $T >$ alarm threshold). The sensor is fitted with a fixed low temperature threshold (Set temperature - 10°C) signaling a pump is too cold.</p>
Motor power sensor	<p>Monitors the power consumed by the machine by generating an alert followed by an alarm as soon as the power is greater than each of its thresholds ; the pump is immediately stopped when alarm threshold is exceeded.</p>
Pressure sensor	<p>Signals exhaust overpressure when the pressure reaches 1450 mbar (exhaust pipe clogging) and stops the pump at 1990 mbar.</p>
E. Analogic sensor	<p>Allows the monitoring of voltage or an input contact with two adjustable thresholds.</p>
LI1, LI2 and LI3 Logic sensors	<p>Allow the monitoring of a logic sensor and to program an alert time.</p>
Auxiliary temperature sensor (option)	<p>Allows the monitoring of the auxiliary temperatures.</p>

The M4 monitoring system parameters

Summary table of monitoring parameters
Max. and min. thresholds

	Unit	Mini.		Alert	
		Mini.	Maxi.	Alert	Alarm
Mass-flowmeter	slm	10	60	15	-
	mn	0	60	0	invalid
ADP temperature sensor	°C	70	130	100	120
Motor power sensor	W	500	4000	2500	4000
E. analogic sensor	mV	0	10000	4000	8000
LI1 logic sensor	mn	0	60	invalid	invalid
LI2 logic sensor	mn	0	60	invalid	invalid
LI3 logic sensor	mn	0	60	invalid	invalid
Auxiliary temperature	°C	0	170	< 20	> 140

At the pump start-up, the monitoring operation will depend on the programming done at the factory. However, the monitoring system can be customized at any time according to the running process, by programming the parameters of the various menus listed in **C 50** with the pump stopped.

Sensor location See sheet **D 10**.

M4 monitoring system function table

Pump configuration

Gain access to parameter programming using the hand-held remote control.

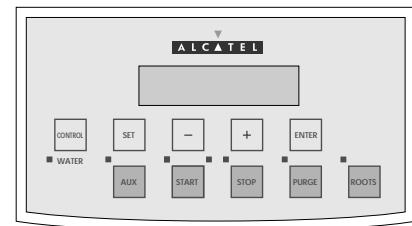

The programming made at the factory is protected by an access code which disables the entry of new parameters.

Press the key **SET**.

Valid the code with **ENTER**.

Access code can be customized (*see folio 7*)

ENTER PASSWORD :

CODE : 0

Parameters can be transferred from one pump to another. This can be done in case of a pump replacement, or for new pump installations (*see C 70*).

M4 monitoring system function table

	Choice	Definition	Initial configuration
LANGUAGE	FRENCH ENGLISH	All the menus are in the selected language.	ENGLISH
SYSTEM SELECT.	ADP122 ADS602 ADS602V ADS1202	Select the pump monitored by the monitoring system. (V indicates that the Roots is fitted with convertor option)	According to the pump
ANALOG INPUT	ENABLED DISABLED	Allows retrieving analogic data. This input is not available on ADS 602V and ADS 1202 systems.	DISABLED
LI1 LOG. INPUT	ENABLED DISABLED	Allows retrieving logic data on LI1 input using a customer supplied sensor (closed when switched off). This input stays DISABLED if parameter LL PUMP OPTION is enabled.	DISABLED
LI2 LOG. INPUT	ENABLED DISABLED	Allows retrieving logic data on LI2 input using a customer supplied sensor (closed when switched off). This input stays DISABLED if ADS 1202 system is selected.	DISABLED
LI3 LOG. INPUT	ENABLED DISABLED	Allows retrieving logic data on LI3 input using a customer supplied sensor (closed when switched off). This input stays DISABLED if parameter LL PUMP OPTION is enabled.	DISABLED
AUTO START.	ENABLED DISABLED	Allows the pump to restart automatically after a power cut, irrespective of the duration.	DISABLED
ROOTS CMD	ENABLED DISABLED	Allows separate control of the Roots START/STOP control from the ADP START/STOP, instead of simultaneous start-up, the Roots is started using ROOTS key or remote controlled.	DISABLED

M4 monitoring system function table

DEFINITION MENU (cont'd)

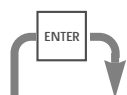

	Choice	Definition	Initial configuration
PURGE CMD	ENABLED DISABLED	Allows independant purge control at pump start-up. The purge flow is controlled by the PURGE key or remote controlled.	ENABLED
BUZZER	ENABLED DISABLED	Controls buzzer on/off in case of defect. Buzzer stop by pressing on ENTER .	ENABLED
N2 STANDBY	ENABLED DISABLED	"Standby purge" option validation during equipment standby phase (additional N2 injection manifold, specified at order, is necessary).	DISABLED
LL PUMP OPTION	ENABLED DISABLED	Allows ADP 122L pump monitoring by displaying operating status.	DISABLED
AUX. TEMPERATURE	ENABLED DISABLED	Auxiliary temperature sensor presence validation.	DISABLED
N2 FLOW OPTION	MFC MFS DISABLED	Choice of the type of flow controller.	MFS
INLET VALVE OPTION	ENABLED DISABLED	Inlet valve presence validation.	DISABLED
THERM. ADP OPTION	ENABLED DISABLED	Temperature regulation validation.	DISABLED
BACKUP POWER OPTION	ENABLED DISABLED	Backup option presence validation.	DISABLED

M4 monitoring system function table

	Selection	Settings limits	Initial configuration
N2 FLOW SENSOR	WARNING threshold	0 to 60 mn OR Disabled	0 mn
	ALARM threshold	0 to 60 mn OR Disabled	DISABLED
PURGE WARNING (*) <i>(only with MFS)</i>		10 to 60 slm (Standard litre minute)	15
INPUT VALUE MFC (*) <i>(only with MFC)</i>		15 to 60 slm (Standard litre minute)	25
ADP TEMPERATURE (*)	INPUT VALUE	70 to 110 °C	100
	ALARM threshold	(Input value + 10 °C) to 130 °C	120
AUX. TEMP SENSOR (*)	WARNING threshold	0 to 140 °C	20
	ALARM threshold	20 °C to 170 °C	140
ADP POWER SENSOR	WARNING threshold	500 to 4000 W	2500
	ALARM threshold	(Warning threshold) to 5000 W	4000
ANALOG INPUT (*)	WARNING threshold	0 V to (Alarm threshold)	4000
	ALARM threshold	(Warning threshold) to 9950 mV	8000
LI1 LOG. SENSOR (*)	WARNING threshold	0 to 60 mn OR Disabled	DISABLED
	ALARM threshold	0 to 60 mn OR Disabled	DISABLED
LI2 LOG. SENSOR (*)	WARNING threshold	0 to 60 mn OR Disabled	DISABLED
	ALARM threshold	0 to 60 mn OR Disabled	DISABLED
LI3 LOG. SENSOR (*)	WARNING threshold	0 to 60 mn OR Disabled	DISABLED
	ALARM threshold	0 to 60 mn OR Disabled	DISABLED

(*) : Accessible menu only if option is validated in DEFINITION menu.

M4 monitoring system function table

SETTING (cont'd)			
	Selection	Settings limits	Initial configuration
PURGE FLOW PROLONGED	WARNING threshold	0 to 120 mn	10 mn
SERIAL LINK	TYPE	RS 232 / RS 485 / NETWORK	RS 232
	ECHO	ENABLED / DISABLED	ENABLED
	SPEED	1200/2400/4800/9600 Bauds	9600
	PARITY	NO / EVEN / ODD	NO
	2 STOP bits	ENABLED / DISABLED	DISABLED
	ADDRESS	0 to 999	0
	TIME - DATE	Month/Day/Year	
Hours/Minutes			
TEMPERATURE UNIT		CELSIUS / FARHENHEIT	CELSIUS
PRESSURE UNIT		mbar / PSI / Torr / hPa	mbar
CONTRAST		Contrast display setting	

M4 monitoring system function table

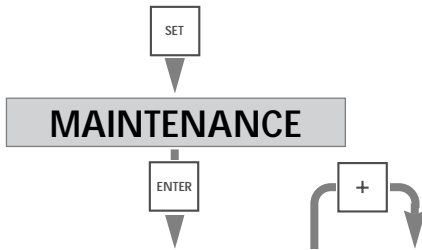

	Settings limits	Initial configuration
RUN TIME	0 to 65500 h	0
ADP MAINTENANCE	0 to 65500 h	0
ADP LP BEARING	0 to 65500 h	0
INSPECT EXHAUST	0 to 65500 h	0
LL MAINTENANCE	0 to 65500 h	0
ROOTS MAINTENANCE	0 to 65500 h	0
ADP MAINT. WARNING	1000 to 34000 h	17000
BEARING WARNING	1000 to 34000 h	8500
EXHAUST WARNING	1000 to 34000 h	8500
ROOTS MAINT. WARNING	1000 to 34000 h	17000
LL MAINT. WARNING	1000 to 34000 h	17000

M4 monitoring system function table

The diagram shows a navigation flow starting from a 'SET' key leading to a 'MANAGEMENT' menu. From 'MANAGEMENT', an 'ENTER' key leads to 'PASSWORD'. A second 'ENTER' key leads to 'Selection', and a '+' key leads to 'Settings limits'. 'Initial configuration' is also indicated as a separate column.

	Selection	Settings limits	Initial configuration
PASSWORD		0 to 65535	0
VERSION	Frame serial Nr		-
	M4 serial Nr		-
	M4 OTP Version		-
	M4 Flash Version		-
	ADP serial Nr		-
	ROOTS serial Nr		-
	Display OTP version	(OTP - One Time Programmable)	-
	Display Flash version		-
STORAGE		ENABLED / DISABLED	DISABLED
CONFIG. SAVE	Save a pump configuration in the hand-held remote control memory.		
CONFIG. LOAD	Allows to record the configuration from hand-held remote control to monitoring system memory.		
OPERATING TIME	Displays the operating times of the various components.		
LAST WARNINGS	Displays the 10 last warnings recorded.		
LAST ALARMS	Displays the 10 last alarms recorded.		

Water flowrate and gas purge according to main semiconductor processes

	Processes	Pump	N2	Temp.	Exhaust heating
CLAEN	Load-lock and transfer chamber pumping	ADP 122 L	0	-	
	Sputtering		0	-	
	Ion implant		0	-	
MEDIUM	Dielectric etch	ADP 122 P or ADS 602 P	20 slm	Not regul.	
	Stripping		20 slm	Not regul.	
	Resist and polyamid etch		20 slm	Not regul.	
	Metal etch (Al, W, Ta, Ti, TiN)		20 slm	90 °C	•
	Polysilicon etch		20 slm	80 °C	•
	Ion implant (source)		35 slm	Not regul.	
	Tungsten CVD (W CVD)		35 slm	Not regul.	
	Titanium and Titanium nitride CVD (Ti, TiN CVD)		35 slm	Not regul.	
	Silicon epitaxy		50 slm	80 °C	
	SiO ₂ CVD using silane as silicon source		35 slm	80 °C	
	Polysilicon CVD		35 slm	80 °C	
	MOCVD		50 slm	80 °C	
HARSH	Non doped SiO ₂ CVD using TEOS	ADS 602 P or ADS 1202 P	35 slm	80 °C	•
	Dopped SiO ₂ CVD using TEOS (PSG, BSG, BPSG)		50 slm	90 °C	•
	SACVD oxid using TEOS		50 slm	90 °C	•
	Nitride and oxi-nitride of silicon PECVD		50 slm	100°C	•
	Silicon nitride LPCVD		50 slm	100°C	•

In any case, water flowrate is 60 l/h, except for model ADS 1202 P, which is 80 l/h.

Saving and remote loading of pump configuration (with M4)

At pump installation or replacement, it may be interesting to copy the configuration (set of all the parameters and operation setting programmed by the user) from a pump to another.



For safety reasons, carry these operations out when pump is switched on but pumping stopped.

Configuration saving

The pump configuration is memorized in the internal electronics of M4 monitoring.

Enter in the menu by **SET**.

Go on using **+** to access the **MANAGEMENT** menu and valid by **ENTER**.

Go on using **+** to access the **CONFIG. SAVE** menu and valid by **ENTER**.

```
DEFINITION
SETTING
MAINTENANCE
>>> MANAGEMENT <<<
```

```
STORAGE
>>>> CONFIG SAVE <<<<
CONFIG. LOAD
OPERATING TIME
```

The pump configuration is then duplicate into the hand-held remote control memory.

Return to main menu and exit the setting mode by **SET**.

Disconnect the hand-held remote control.

Saving and remote loading of pump configuration (with M4)

Remote loading

Connect the hand-held remote control onto the pump to configure.

Take the control of the pump from the hand-held remote control (★ at cover left of the display).

Load the configuration previously saved into the pump by selecting the **CONFIG. LOAD** menu from **MANAGEMENT** menu. The former configuration is automatically reset.

All pump parameters are loaded remotely, except the options which have to be locally configured according to the pump:

- buzzer
- unit of temperature
- unit of pressure
- RS link
- time and date

M4 monitoring setting for transport

Setting of "storage" mode for transports and prolonged storage

Gain access to **MANAGEMENT** menu by successive press on +.

```
DEFINITION
SETTING
MAINTENANCE
>>>> MANAGEMENT <<<<
```

Enter the sub menu **STORAGE** by pressing **ENTER** then select **ENABLED** using the key +.
Valid with **ENTER**.

```
STOCK                150H
Pumping stopped
01/12/98              13H56
```

The pump start up is now not possible, second counter is blocked.

Note : At switching on, **STORAGE** mode is automatically deleted. Date and Time reset is only necessary (see **C 20**).

User's Manual ADP/ADS Series Two

Maintenance

■ Safety instruction related to maintenance	■ <i>D 00</i>
■ First level of maintenance	■ <i>D 10</i>
■ Maintenance frequency	■ <i>D 20</i>
■ Diagnosis and troubleshooting	■ <i>D 30</i> to <i>D 140</i>

Safety instruction related to maintenance

This chapter describes the main preventive maintenance operations and provides a guide for first diagnosis in the event of an incident.



Standard precautions before any maintenance operation:

Before performing a maintenance operation, switch off the pump by setting the main switch to "0" and disconnect the mains cable.



CAUTION: before any operation, check the pumping conditions of the installation: toxicity, corrosion, possible radioactivity of the pumped gases.



Product tightness is guaranteed upon leaving the factory for normal operating conditions.

It is the responsibility of the user to ensure that the level of tightness is maintained when pumping dangerous gases.

Recommandations (except model ADP 122 L)

Purge the installation with dry nitrogen.

The flush is performed automatically when the pump is stopped (normal stop, or due to a fault) if a maintained level of purge gas has been programmed.

Otherwise, proceed as follows:

If the pump is remote controlled, remove the connections on J14 and J1 connectors, at the rear of the pump, and connect the cover plug connectors (supplied with the machine) instead. Program "**PURGE FLOW PROLONGED**" and set the **PURGE COMMAND** on **DISABLED**.

Press **START**, followed by **STOP** on the front panel, the gas flush is performed after the pump is stopped.

Wear gloves, protective glasses and, if necessary, a breathing mask.

Ventilate the premises well.

Do not dispose of residue, if necessary, have it destroyed by a qualified organization.

Safety instruction related to maintenance

- Certain gases can become corrosives and toxic when trapped in oil. Always wear protective gloves when handling used and dirty pump oil, drain it into a closable container, and do not breathe the fumes of the oil. Always use fully self-contained breathing apparatus.
- When the exhaust is maintained, avoid any contact with the reaction by-products (deposit, powder..) strongly corrosive: wear gloves even a breathing mask.
Cleaning procedure can produce violent reactions and dangerous gas releases.
We recommend to ventilate the premises well and disassemble the equipment under a ventilated hood.
- Always dispose of used dirty oil, or sub-products properly and in compliance with all local, state and federal environmental laws and regulations.



After a complete maintenance operation, on the pump or on the installation, it is recommended to perform a helium leak test.

First level of maintenance



Study the safety instructions related to maintenance
(See D 00).

When a problem occurs, the user is informed by:

- the relevant fault indicator light which is located on the front panel: orange lit in case of alert, red lit in case of alarm (followed by a pump stop),
- the audible buzzer warning (if preselected),
- the fault contacts on the J14 remote connector at the rear of the monitoring system which close,
- the stopping of the pumping although the STOP command has not been given,
- the display of fault message on the display of the hand-held remote control,
- a message via the RS 232 or RS 485 link on a micro-computer.

Maintenance time monitoring

Depending on the maintenance parameter programmed, when the operating time before maintenance has expired, the screen display alternates between operating parameters and the corresponding alert message.

The red indicator light is lit on front panel.

Press the **SET** button during the pumping.

The operating times for components are in turn displayed.

This information can be read at any time using the **MAINTENANCE** menu.

Perform maintenance on the relevant parts.

Maintenance operations

See *Section E*.

First level of maintenance

Location of electrical components (electrical cabinet)

The diagnosis and troubleshooting guide (*from D 30*) may lead to check the electrical components of the monitoring cabinet described below:

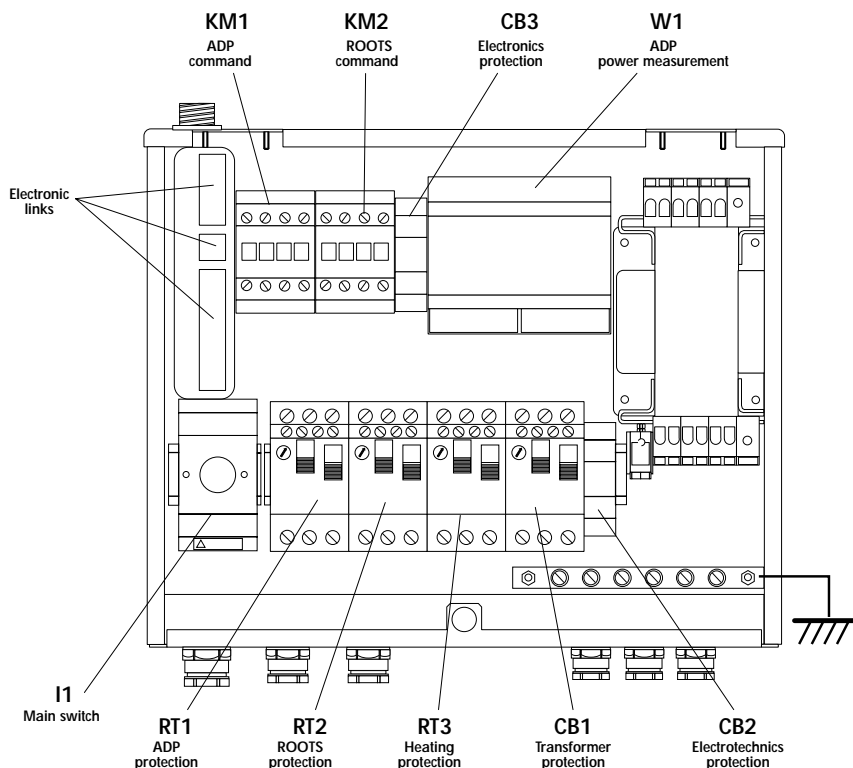

Breakers rating

ADP 122 / ADS 602

Voltage	RT1	RT2	RT3	CB1
L.V. 200 to 230 V - 50/60 Hz	10 A	10 A	1 A	1 A
H.V. 380 to 480 V - 50/60 Hz	8 A	8 A	0.7 A	0.7 A

ADS 1202

Voltage	RT1	RT2	RT3	CB1
L.V. 200 to 230 V - 50/60 Hz	10 A	14 A	1 A	1 A
H.V. 380 to 480 V - 50/60 Hz	8 A	12 A	0.7 A	0.7 A

First level of maintenance

Electrical interfaces lay-out at the rear of the pump

P model pump

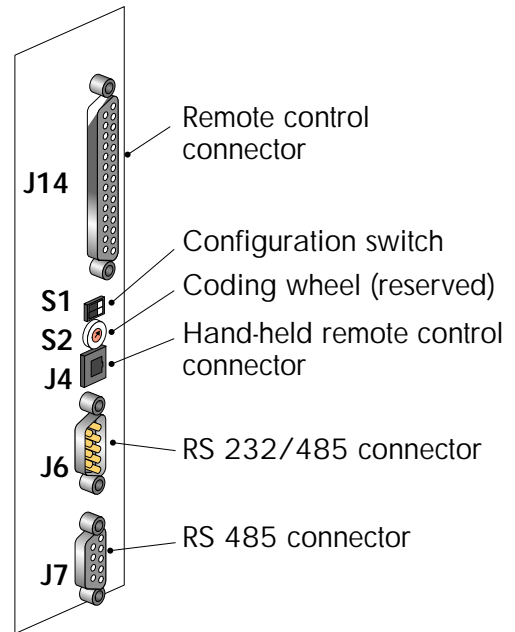

L model pump

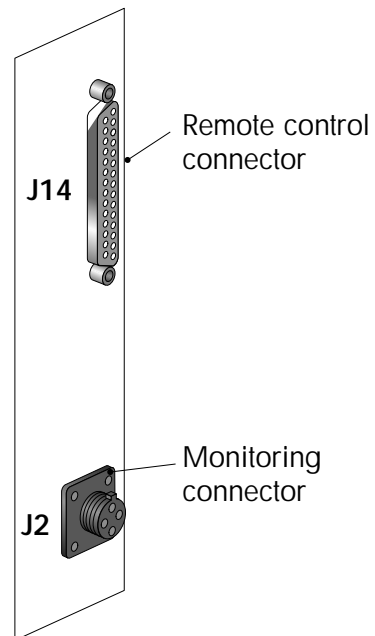

First level of maintenance

Sensors connectors
lay-out at the rear of
the monitoring system

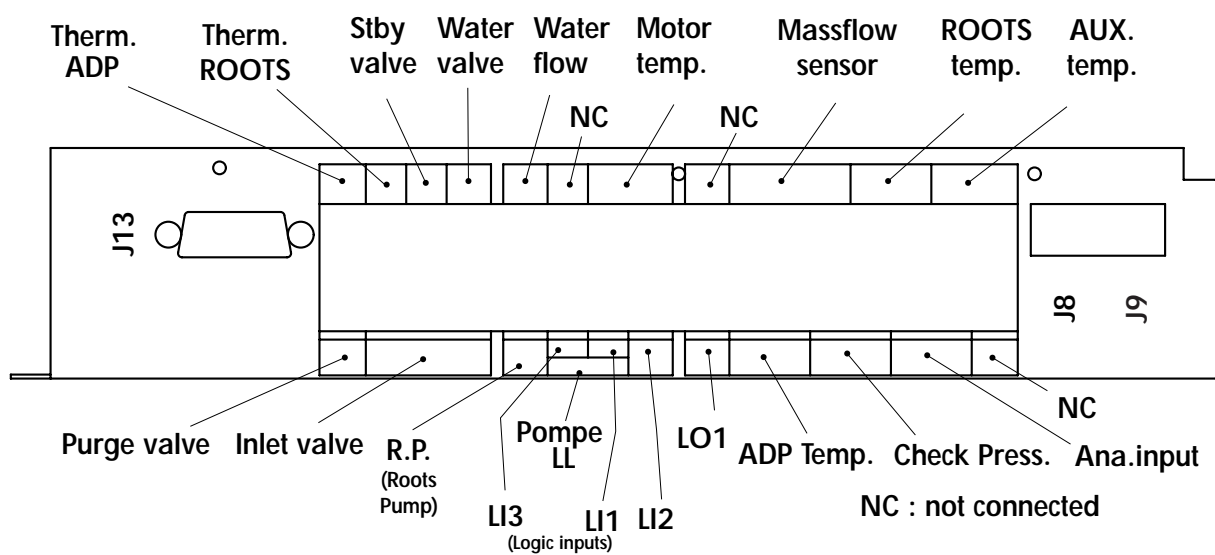

Maintenance frequency

Clean processes (see C 60)

	Description	17000 h	34000 h	Time* required	Equipment required		Specific tool	Comments
					Description	P/N		
A ADP 122 P - ADP 122 L	Part overhaul			1 h	Anti-suckback valve maintenance kit	106624	Consult Alcatel	
	Anti-suckback valve				Minor kit ADP 122 P	107057		
	LP bearing repl.				Minor kit ADP 122 L	106804		
	Full overhaul			10 h*	Major kit ADP 122 P	107055	Consult Alcatel	1 oil filling (see B 40)
					Major kit ADP 122 L	106803		
					Fluid Alcatel 113 (0.5 l)	064657		

* *Testing and cleaning time not included*

Maintenance times can change according to processes and equipments used.

Maintenance frequency

Medium processes (see C 60)

	Description	13000 h	26000 h	Time* required	Equipment required		Specific tool	Comments
					Description	P/N		
A ADP 122 P	Part overhaul			1 h	Anti-suckback valve maintenance kit	106624	Consult Alcatel	
	Anti-suckback valve				Minor kit ADP 122 P	107057		
	LP bearing repl.							
	Full overhaul			10 h*	Major kit ADP 122 P	107055	Consult Alcatel	1 oil filling (see B 40)
					Fluid Alcatel 113 (0.5 l)	064657		
B Roots 602	Full overhaul			8 h*	Major kit	106927	Consult Alcatel	2 oil fillings (see B 40)
					Fluid Alcatel 113 (0.5 l)	064657		
C Roots 1202	Full overhaul			12 h*	Major kit	106790	Consult Alcatel	5 oil fillings (see B 40)
					Fluid Alcatel 113 (0.5 l)	064657		

A : ADP 122 P Maintenance

A+B : ADS 602 P Maintenance

A+C : ADS 1202 P Maintenance

* Testing and cleaning time not included

Maintenance times can change according to processes and equipments used.

Maintenance frequency

Harsh processes (see C 60)

	Description	8500 h	17000 h	Time* required	Equipment required		Specific tool	Comments
					Description	P/N		
A ADP 122 P	Part overhaul			1 h	Anti-suckback valve maintenance kit	106624	Consult Alcatel	
	Anti-suckback valve				Minor kit ADP 122 P	107057		
	LP bearing repl.							
	Full overhaul			10 h*	Major kit ADP 122 P	107055	Consult Alcatel	1 oil filling (see B 40)
					Fluid Alcatel 113 (0.5 l)	064657		
B Roots 602	Full overhaul			8 h*	Major kit	106927	Consult Alcatel	2 oil fillings (see B 40)
					Fluid Alcatel 113 (0.5 l)	064657		
C Roots 1202	Full overhaul			12 h*	Major kit	106790	Consult Alcatel	5 oil fillings (see B 40)
					Fluid Alcatel 113 (0.5 l)	064657		

A : ADP 122 P Maintenance

* Testing and cleaning time not included

A+B : ADS 602 P Maintenance

A+C : ADS 1202 P Maintenance

Maintenance times can change according to processes and equipments used.

Diagnosis and trouble shooting

Pump does not start	...Mains presence light indicator does not switch on	D 40
	...Hand-held remote control display is not lighting up	D 50
	...Display is showing a message or an alarm	D 60
Pump only starts-up	...Roots does not start	D 70
The pump is running and then is showing an alert or alarm message	...Electrical problems	D 80
	...Facilities problems	D 90
	...Temperature or pressure problems	D 100
	...Temperature problems (ADP 122 L)	D 101
	... Maintenance problem	D 110
	...Options and accessory problems	D 120
	...Analogic and logic input problems	D 130
The pump is running	...No message	D 140

**Pump does not start
Mains presence light indicator
does not switch on**

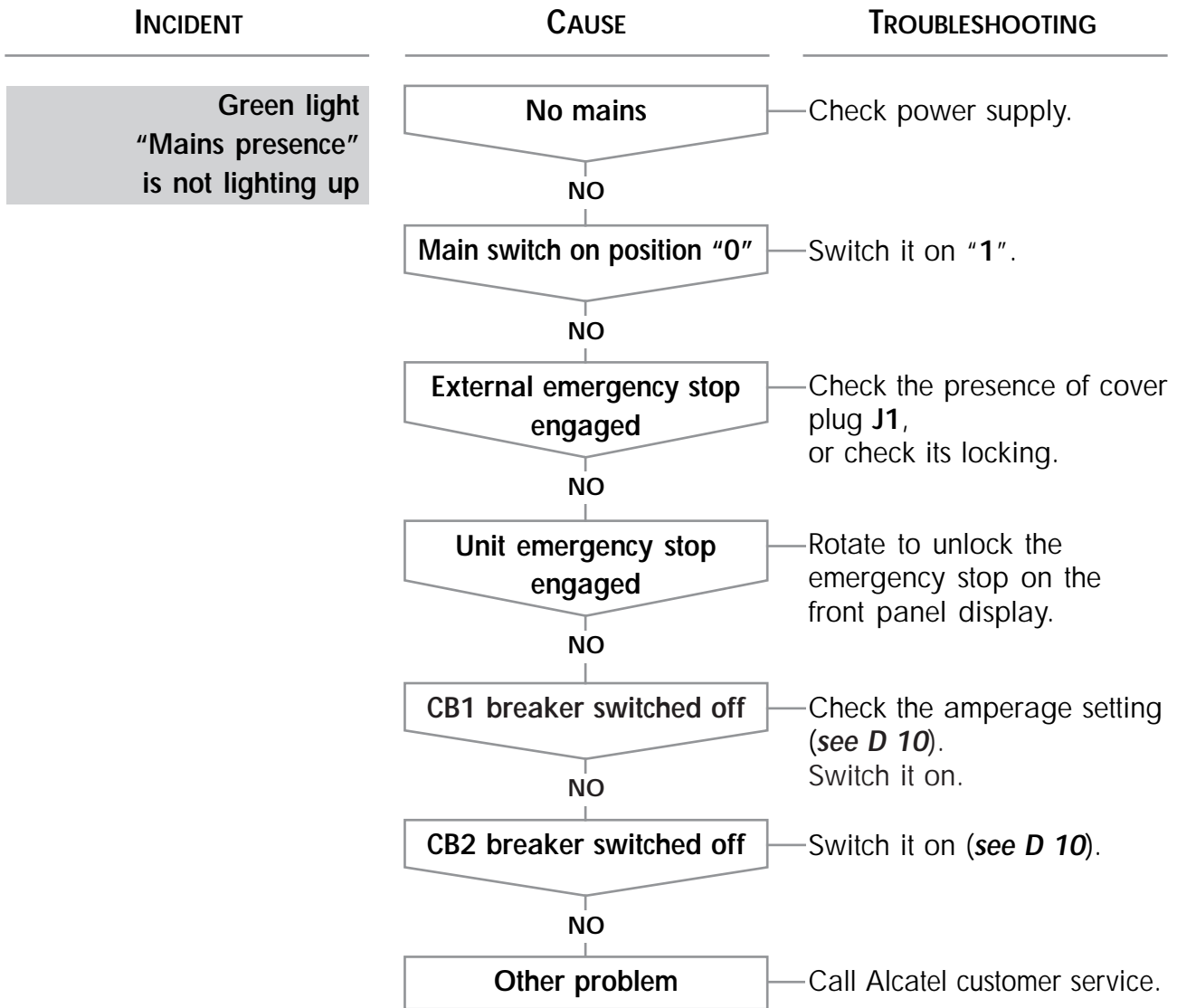

**Pump does not start
Hand-held remote control display
is not lighting up**

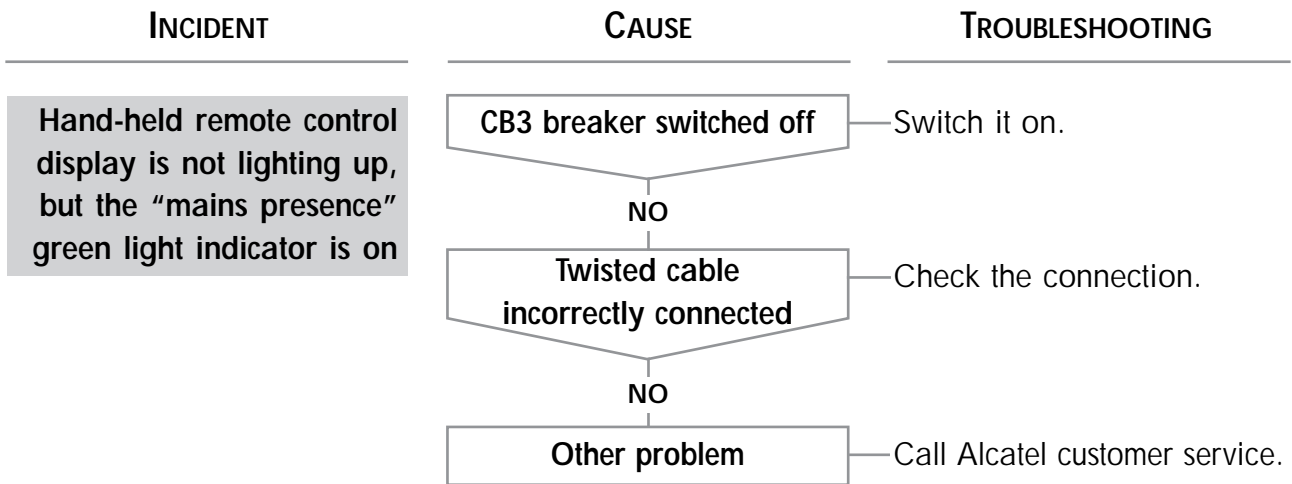

**Pump does not start
Display is showing a message
or an alarm**

INCIDENT	CAUSE	TROUBLESHOOTING
<p>Hand-held remote control display is showing</p> <p>MONITOR M4 D 9111 VX.XX</p>	<p>Hand-held remote control is on soft loading configuration</p> <p>NO</p> <p>Other problem</p>	<p>Set the switch S1-1 to "OFF" (see C 10). Switch off for 10 s, then switch on again.</p> <p>Call Alcatel customer service.</p>
<p>Hand-held remote control display is showing</p> <p>WAIT ???</p>	<p>Electronic is in "slave" mode : without hand-held remote control</p> <p>NO</p> <p>Other problem</p>	<p>Set the switch S2 to "0", Switch off for 10 s, then switch on again. (see D 10).</p> <p>Call Alcatel customer service.</p>

Pump does not start Display is showing a message or an alarm

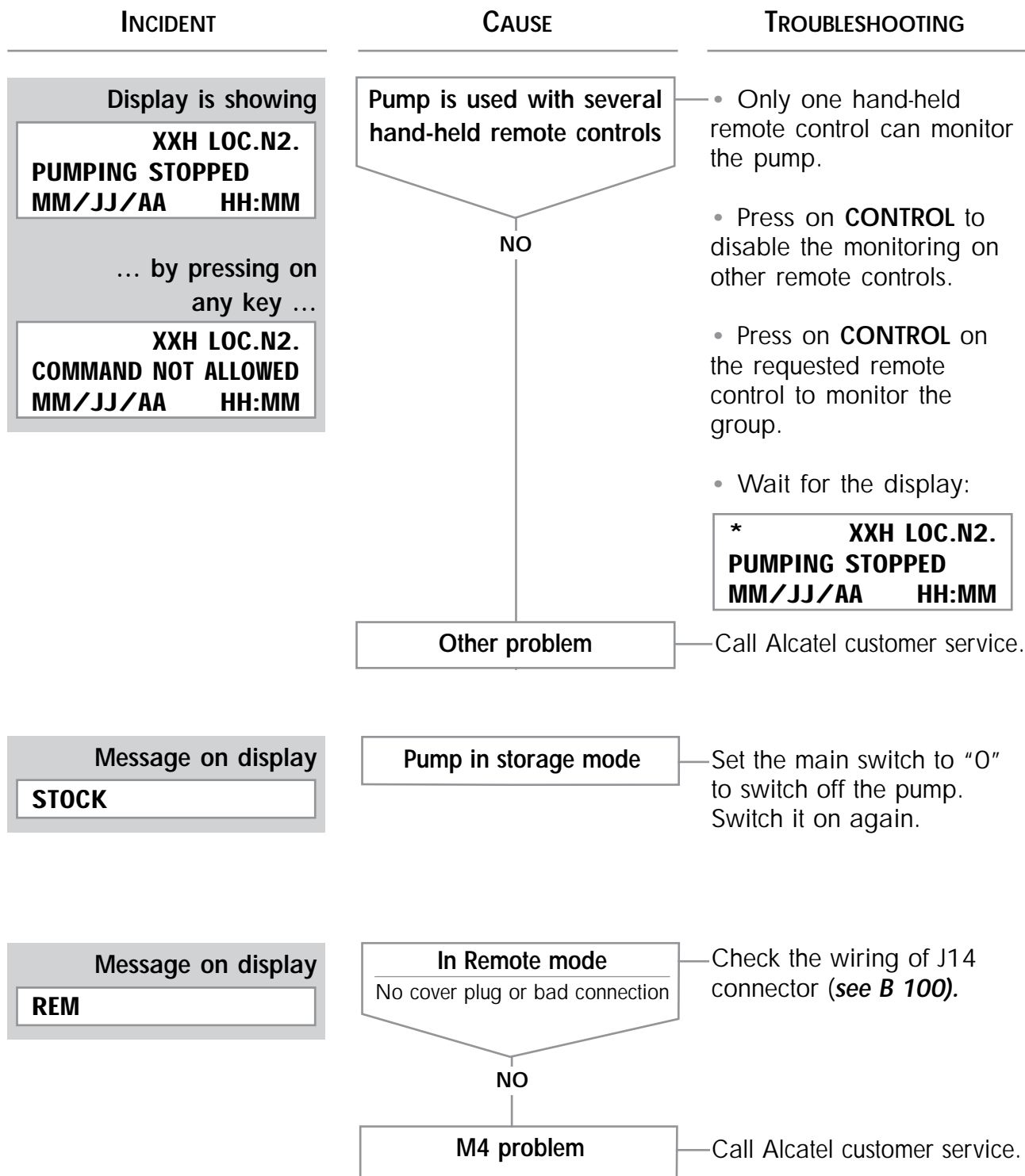

Pump does not start Display is showing a message or an alarm

INCIDENT	CAUSE	TROUBLESHOOTING
<p>Alert then Alarm</p> <p>POWER SUPPLY</p>	<p>Main power is not correct</p> <p>NO</p> <p>Other problem</p>	<p>Check the main power.</p> <p>Call Alcatel customer service.</p>
<p>Alarm</p> <p>EMERGENCY STOP</p>	<p>Pump emergency stop is engaged</p> <p>NO</p> <p>Other problem</p>	<p>Rotate to unlock the emergency stop on the front panel display.</p> <p>Call Alcatel customer service.</p>
<p>Alarm</p> <p>ADP BREAKER</p>	<p>RT1 breaker switched off</p> <p>NO</p> <p>Other problem</p>	<ul style="list-style-type: none"> • Check RT1 setting (see D 10). • Check that ADP is not seized up (see E 30). • Switch RT1 on. <p>Call Alcatel customer service.</p>
<p>Alarm</p> <p>ROOTS BREAKER</p>	<p>RT2 breaker switched off</p> <p>NO</p> <p>Other problem</p>	<ul style="list-style-type: none"> • Check that ADS option is selected. • Check RT2 setting (see D 10). • Switch RT2 again. <p>Call Alcatel customer service.</p>
<p>Alert then Alarm</p> <p>EXHAUST PRESSURE</p>	<p>Exhaust pressure ≥ 1990 mbar</p> <p>NO</p> <p>Other problem</p>	<p>Check exhaust pipe.</p> <p>Call Alcatel customer service.</p>

Pump only starts-up Roots does not start

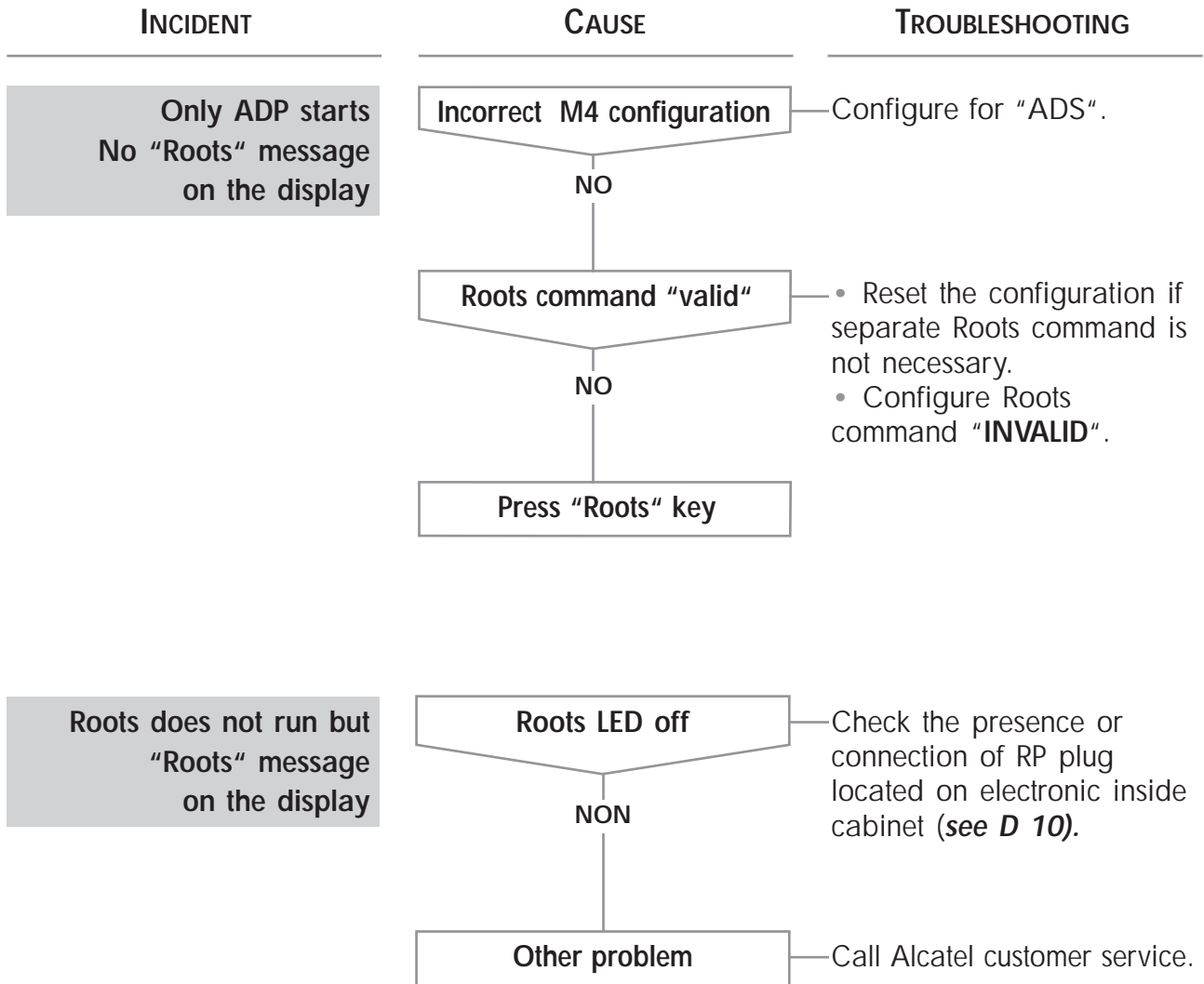

The pump is running and then is showing an alert or alarm message Electrical problems

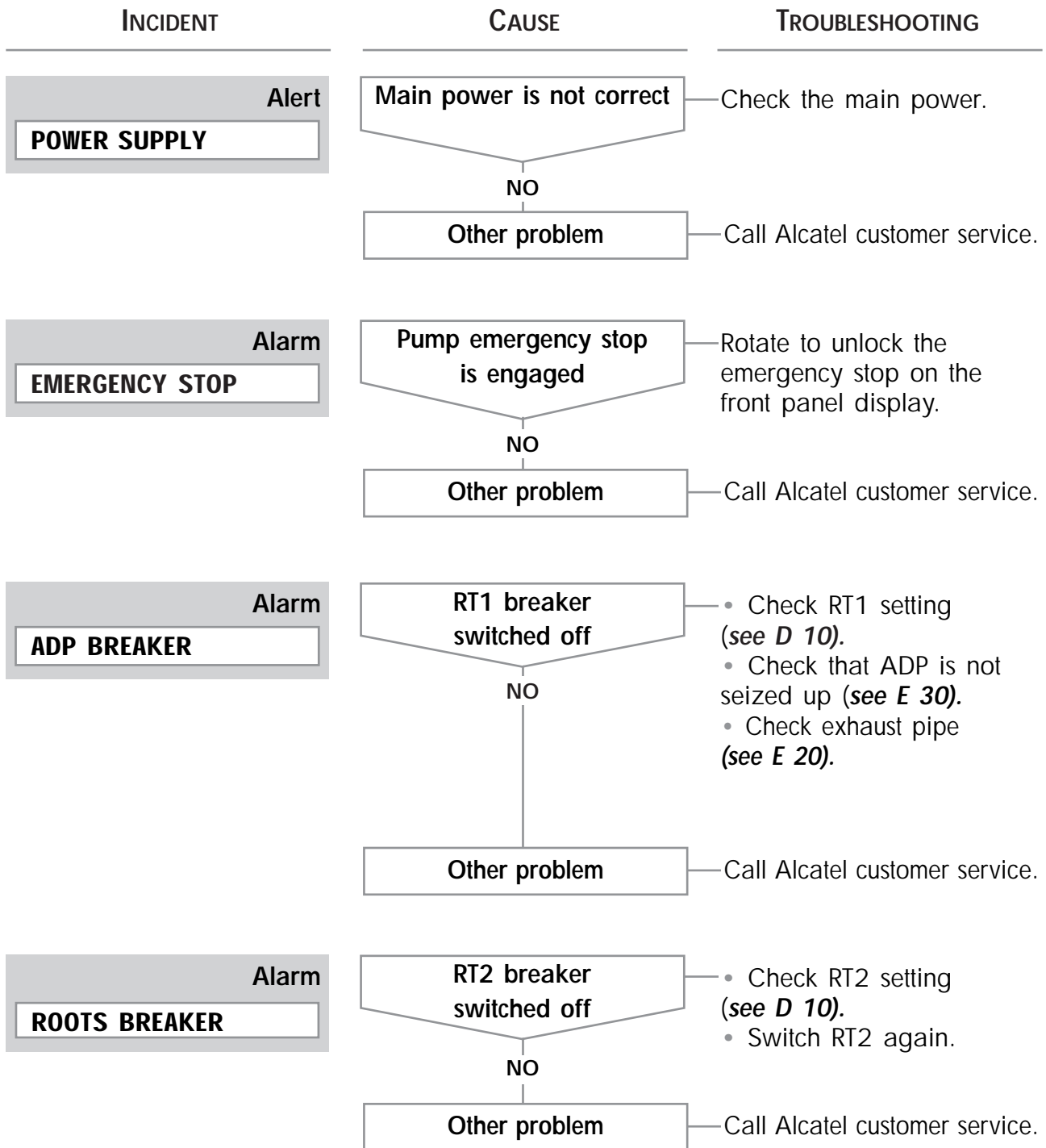

The pump is running and then is showing an alert or alarm message Electrical problems

INCIDENT	CAUSE	TROUBLESHOOTING
<p style="text-align: right;">Alarm</p> <p>ADP CONT</p>	<p>KM1 contactor not closed</p> <p style="text-align: center;">NO</p> <p>Other problem</p>	<ul style="list-style-type: none"> • Check CB2 (see D 10). • Check that there is a strap between pins 2 and 3 of emergency stop terminal (see B 110). <p>Call Alcatel customer service.</p>
<p style="text-align: right;">Alarm</p> <p>ROOTS CONT</p>	<p>KM2 contactor not closed</p> <p style="text-align: center;">NO</p> <p>Other problem</p>	<ul style="list-style-type: none"> • Check CB2 (see D 10). • Check that there is a strap between pins 2 and 3 of emergency stop terminal (see B 110). • Check external emergency switch (J1). <p>Call Alcatel customer service.</p>
<p style="text-align: right;">Alert and Alarm</p> <p>CONSUMPTION</p>	<p>Incorrect rotation direction</p>	<p>Check the direction of rotation of the pump (see B 80).</p>
<p style="text-align: right;">Power = 0 or Power > threshold</p>	<p>Incorrect threshold setting</p> <p style="text-align: center;">NO</p> <p>Other problem</p>	<ul style="list-style-type: none"> • Check the settings of monitoring thresholds. • Check mechanical state of ADP (see E 30). • Check exhaust pipe (see E 20). <p>Call Alcatel customer service.</p>

The pump is running and then is showing an alert or alarm message Facilities problems

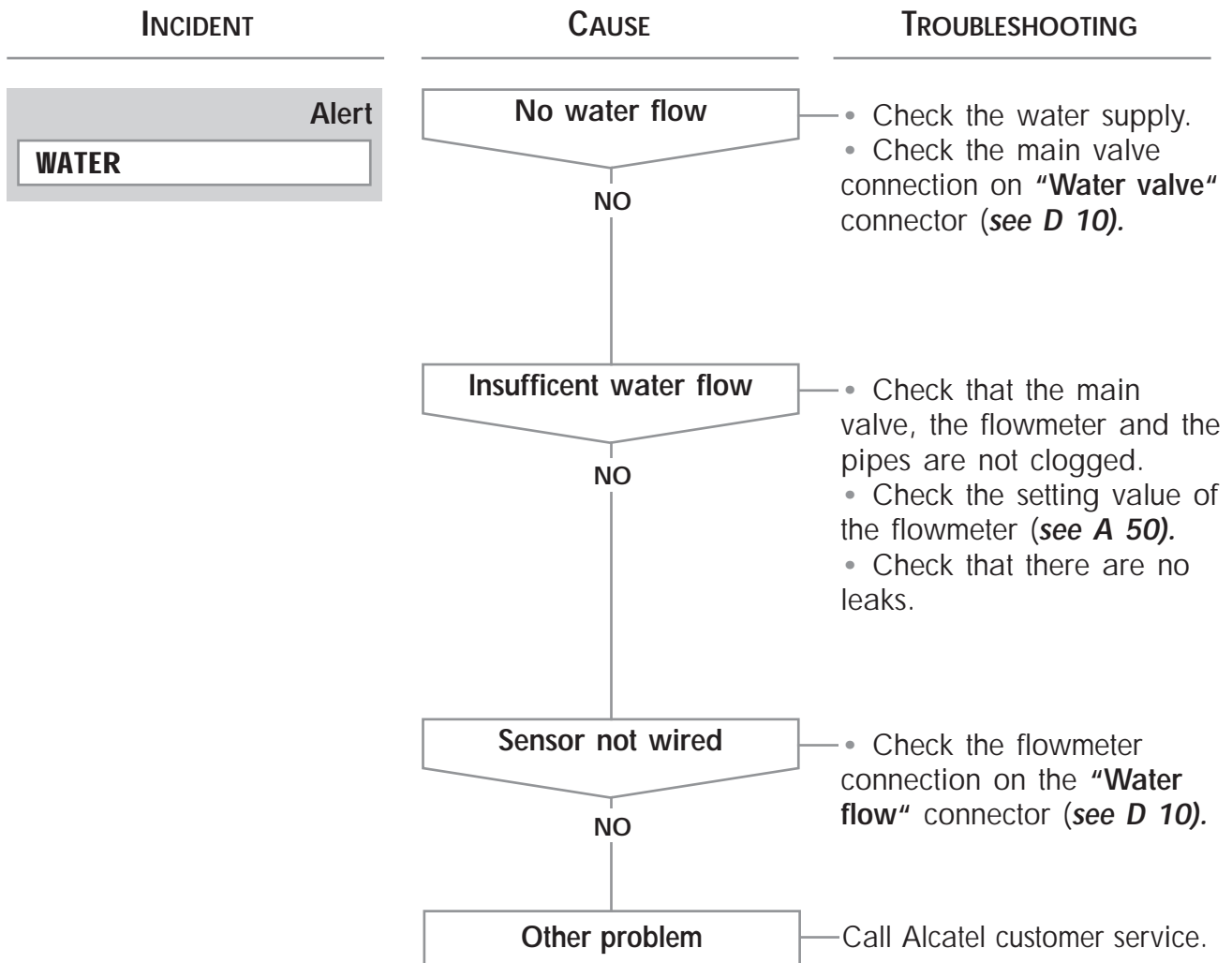

The pump is running and then is showing an alert or alarm message Facilities problems

INCIDENT	CAUSE	TROUBLESHOOTING
<p style="text-align: center;">Alert and Alarm</p> <div style="border: 1px solid black; padding: 2px; width: fit-content; margin: 0 auto;">N2 FLOW</div>	<div style="border: 1px solid black; padding: 5px; margin-bottom: 10px; text-align: center;"> <p>No purge flow</p> <p style="font-size: small;">NO</p> </div> <div style="border: 1px solid black; padding: 5px; margin-bottom: 10px; text-align: center;"> <p>Insufficient purge flow</p> <p style="font-size: small;">NO</p> </div> <div style="border: 1px solid black; padding: 5px; margin-bottom: 10px; text-align: center;"> <p>Incorrect threshold setting</p> <p style="font-size: small;">NO</p> </div> <div style="border: 1px solid black; padding: 5px; margin-bottom: 10px; text-align: center;"> <p>Sensor problem</p> <p style="font-size: small;">NO</p> </div> <div style="border: 1px solid black; padding: 5px; text-align: center;"> <p>Other problem</p> </div>	<ul style="list-style-type: none"> • Check nitrogen supply. • Check the main valve connection on Purge valve connector (<i>see D 10</i>). <ul style="list-style-type: none"> • Check the setting of nitrogen flow (<i>see C 60</i>). • Check that there is no leak. <ul style="list-style-type: none"> • Check the Alert threshold. <ul style="list-style-type: none"> • Check the sensor connection on MassFlow Sensor connector (<i>see D 10</i>). <ul style="list-style-type: none"> • Call Alcatel customer service.

The pump is running and then is showing an alert or alarm message Temperature or pressure problems

INCIDENT	CAUSE	TROUBLESHOOTING
<p style="text-align: right;">Alert</p> <div style="border: 1px solid black; padding: 5px; width: fit-content;">MOTOR TEMP.</div>	<div style="border: 1px solid black; padding: 5px; text-align: center;">Motor temperature is > 50°C</div> <p style="text-align: center;">NO</p> <div style="border: 1px solid black; padding: 5px; text-align: center;">Sensor problem</div> <p style="text-align: center;">NO</p> <div style="border: 1px solid black; padding: 5px; text-align: center;">Other problem</div>	<p>See water flowrate alert (D 90).</p> <p>Check the sensor connection on Mot. temp. connector (see D 10).</p> <p>Call Alcatel customer service.</p>
<p style="text-align: right;">Alarm</p> <div style="border: 1px solid black; padding: 5px; width: fit-content;">MOTOR TEMP.</div>	<div style="border: 1px solid black; padding: 5px; text-align: center;">Motor temperature is > 65°C</div> <p style="text-align: center;">NON</p> <div style="border: 1px solid black; padding: 5px; text-align: center;">Sensor problem</div> <p style="text-align: center;">NO</p> <div style="border: 1px solid black; padding: 5px; text-align: center;">Other problem</div>	<p>See water flowrate alert (D 90).</p> <p>Check the sensor connection on Mot. temp. connector (see D 10).</p> <p>Call Alcatel customer service.</p>
<p style="text-align: right;">Alert</p> <div style="border: 1px solid black; padding: 5px; width: fit-content;">ADP TEMP.</div>	<div style="border: 1px solid black; padding: 5px; text-align: center;">Temperature control valve supply problem</div> <p style="text-align: center;">NO</p> <div style="border: 1px solid black; padding: 5px; text-align: center;">Cooling problem</div> <p style="text-align: center;">NO</p> <div style="border: 1px solid black; padding: 5px; text-align: center;">Other problem</div>	<p>Check the temperature control valve connection on Therm. ADP connector (see D 10).</p> <p>See water flowrate alert (D 90).</p> <p>Call Alcatel customer service.</p>
<p>Pump temperature is > of 10°C to the temperature control setting value</p>	<div style="border: 1px solid black; padding: 5px; text-align: center;">Defective control valve</div>	<p>Call Alcatel customer service.</p>
<p>Pump temperature is < of 10°C to the temperature control setting value</p>		

The pump is running and then is showing an alert or alarm message Temperature or pressure problems

INCIDENT	CAUSE	TROUBLESHOOTING
<p style="text-align: right;">Alarm</p> <div style="border: 1px solid black; padding: 2px; width: fit-content;">ADP TEMP.</div>	<div style="border: 1px solid black; padding: 5px; text-align: center;">Defective temperature sensor</div> <p style="text-align: center;">NO</p> <div style="border: 1px solid black; padding: 5px; text-align: center;">Other problem</div>	<p>Check the sensor connection on ADP.Temp connector (see D 10).</p> <p>Call Alcatel customer service.</p>
<p>Pump temperature reaches temperature control setting value ± 10 °C but the display is 0 or 170 °C</p>	<div style="border: 1px solid black; padding: 5px; text-align: center;">Temperature control valve not connected</div> <p style="text-align: center;">NO</p> <div style="border: 1px solid black; padding: 5px; text-align: center;">Cooling problem</div> <p style="text-align: center;">NO</p> <div style="border: 1px solid black; padding: 5px; text-align: center;">Other problem</div>	<p>Check the temperature control valve connection on Therm. ADP connector (see D 10).</p> <p>See water flowrate alert (D 90).</p> <p>Call Alcatel customer service.</p>
<p>Pump temperature is higher than alarm threshold</p>	<div style="border: 1px solid black; padding: 5px; text-align: center;">Defective temperature sensor</div> <p style="text-align: center;">NO</p> <div style="border: 1px solid black; padding: 5px; text-align: center;">Other problem</div>	<p>Check the sensor connection on ADP.Temp connector (see D 10).</p> <p>Call Alcatel customer service.</p>
<p>Pump temperature is lower than alarm threshold</p>		

The pump is running and then is showing an alert or alarm message Temperature or pressure problems

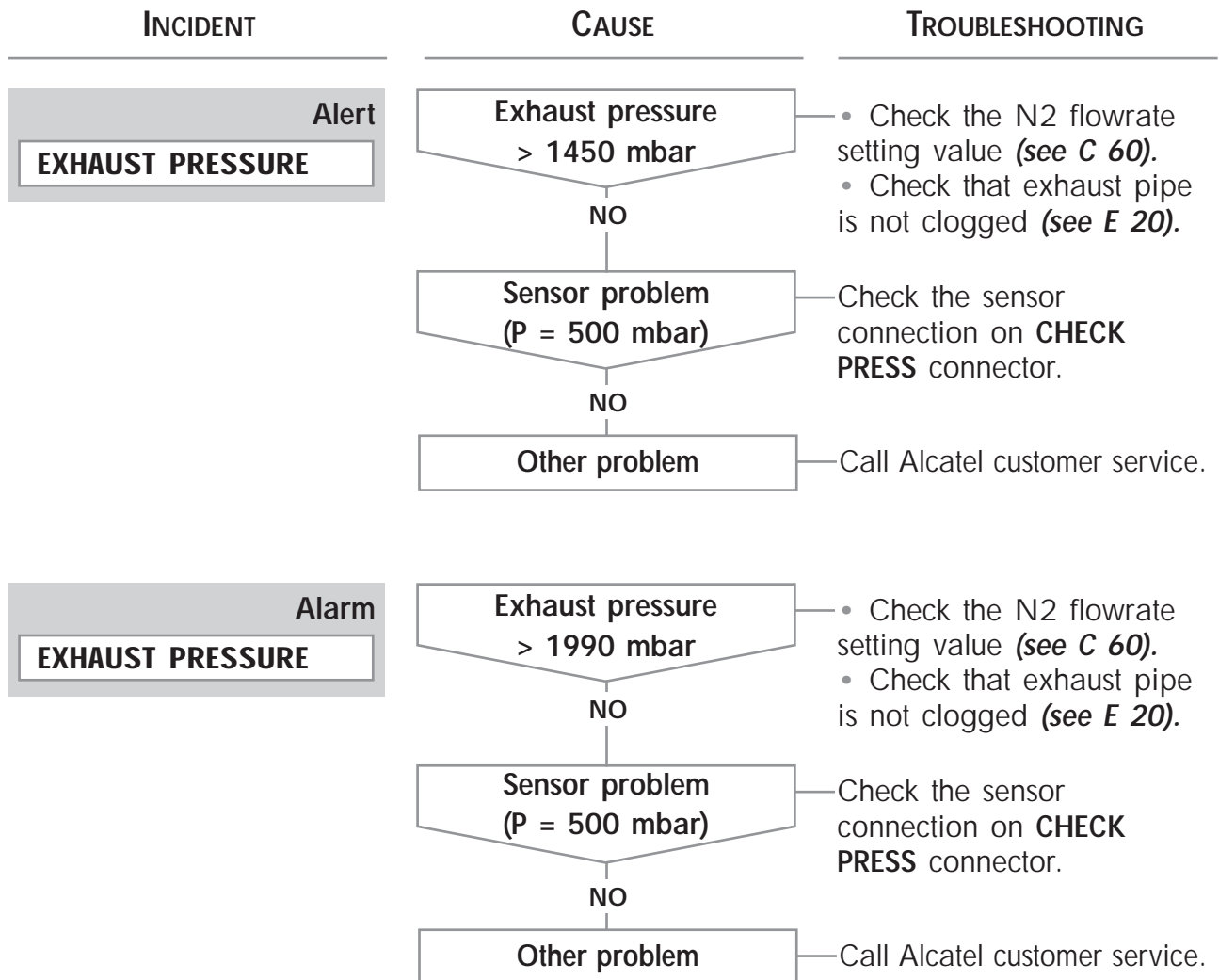

The pump is running and then is showing an alert or alarm message Temperature problem on ADP 122 L

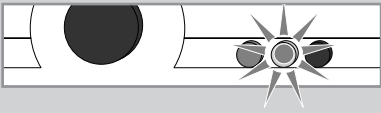
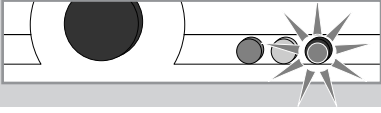
INCIDENT	CAUSE	TROUBLESHOOTING
<p>The alert light indicator (Yellow) is lit up on front display panel</p> 	<p>Motor temperature is $> 50^{\circ}\text{C}$</p> <p>NO</p> <p>Sensor problem</p> <p>NO</p> <p>Other problem</p>	<p>See water flowrate alert (D 90).</p> <p>Check the sensor connection on the "ADP Temp." connector (see D 10).</p> <p>Call Alcatel customer service.</p>
<p>The alarm light indicator (Red) is lit up on front display panel</p> 	<p>Motor temperature is $> 65^{\circ}\text{C}$</p> <p>NO</p> <p>Sensor problem</p> <p>NO</p> <p>Other problem</p>	<p>See water flowrate alert (D 90).</p> <p>Check the sensor connection on the "ADP Temp." connector (see D 10).</p> <p>Call Alcatel customer service.</p>

The pump is running and then is showing an alert or alarm message Maintenance problem

INCIDENT

Alert

**ADP MAINTENANCE
ADP LP BEARING
INSPECT EXHAUST
ROOTS MAINTENANCE
LL MAINTENANCE**

CAUSE

The maintenance threshold of a parameter is reached

TROUBLESHOOTING

- Check maintenance thresholds.
- Perform the maintenance and reset the corresponding timer.

The pump is running and then is showing an alert or alarm message Options and accessory problems

INCIDENT	CAUSE	TROUBLESHOOTING
<p style="text-align: right;">Alert</p> <p>INLET VALVE</p>	<p>Incorrect monitoring configuration</p>	<p>Check that "INLET VALVE OPTION" is not valid</p>
<p>There is no isolating valve at inlet</p>	<p>The valve does not close at pump stop or does not open at start-up</p>	<ul style="list-style-type: none"> • Check compressed air supply. • Check valve condition.
<p>There is an isolating valve at inlet</p>	<p style="text-align: center;">NO</p> <p>Other problem</p>	<p>Call Alcatel customer service.</p>
<p style="text-align: right;">Alert</p> <p>AUX. TEMPERATURE</p>	<p>Incorrect monitoring configuration</p>	<p>Check that "AUX. TEMPERATURE" option is not valid.</p>
<p>"AUX TEMPERATURE" input not used</p>	<p>Incorrect kind of probe</p>	<p>Check that the sensor is a PT 100 type probe.</p>
<p>"AUX TEMPERATURE" input is used</p>	<p style="text-align: center;">NO</p> <p>T < lower or T > higher alert threshold</p>	<ul style="list-style-type: none"> • Check that the measured temperature corresponds to the display. • Check the thresholds.
	<p style="text-align: center;">NO</p> <p>Incorrect connection (displayed temp. = 170°C)</p>	<ul style="list-style-type: none"> • Check that the sensor is wired between pins 17 and 18 of "AUX.TEMP." connector. • Remake the connection (see D 10).
	<p style="text-align: center;">NO</p> <p style="text-align: center;">↓</p>	

The pump is running and then is showing an alert or alarm message Options and accessory problems

INCIDENT	CAUSE	TROUBLESHOOTING
<p>Alert (<i>continued</i>)</p> <p>AUX. TEMPERATURE</p>	<p>Sensor problem</p> <p>NO</p> <p>Other problem</p>	<p>Change sensor.</p> <p>Call Alcatel customer service.</p>
<p>Alert</p> <p>VARIATOR</p>	<p>Incorrect monitoring configuration</p>	<p>Check that "SYSTEM SELECT." menu is properly configured.</p>
<p>Variator option is not used</p>	<p>Mechanical problem</p>	<ul style="list-style-type: none"> • Check that the pump is not seized or clogged (<i>see E 30</i>). • Check exhaust pipe condition (<i>see E 20</i>).
<p>Roots does not run at nominal speed</p>	<p>Defective wiring or variator</p>	<p>Call Alcatel customer service.</p>
<p>Alert or Alarm</p> <p>LOAD LOCK</p>	<p>Incorrect monitoring configuration</p>	<p>Check that "LL PUMP OPTION" is not valid.</p>
<p>LI1 and LI3 logic inputs are not used to monitor a LL pump</p>	<p>LL pump problem</p> <p>NO</p> <p>Wiring problem</p> <p>NO</p> <p>Other problem</p>	<p>See <i>D 101</i>.</p> <p>Check the connections on LI1 and LI3 connectors (<i>see D 10</i>).</p> <p>Call Alcatel customer service.</p>

The pump is running and then is showing an alert or alarm message Analogic and logic input problems

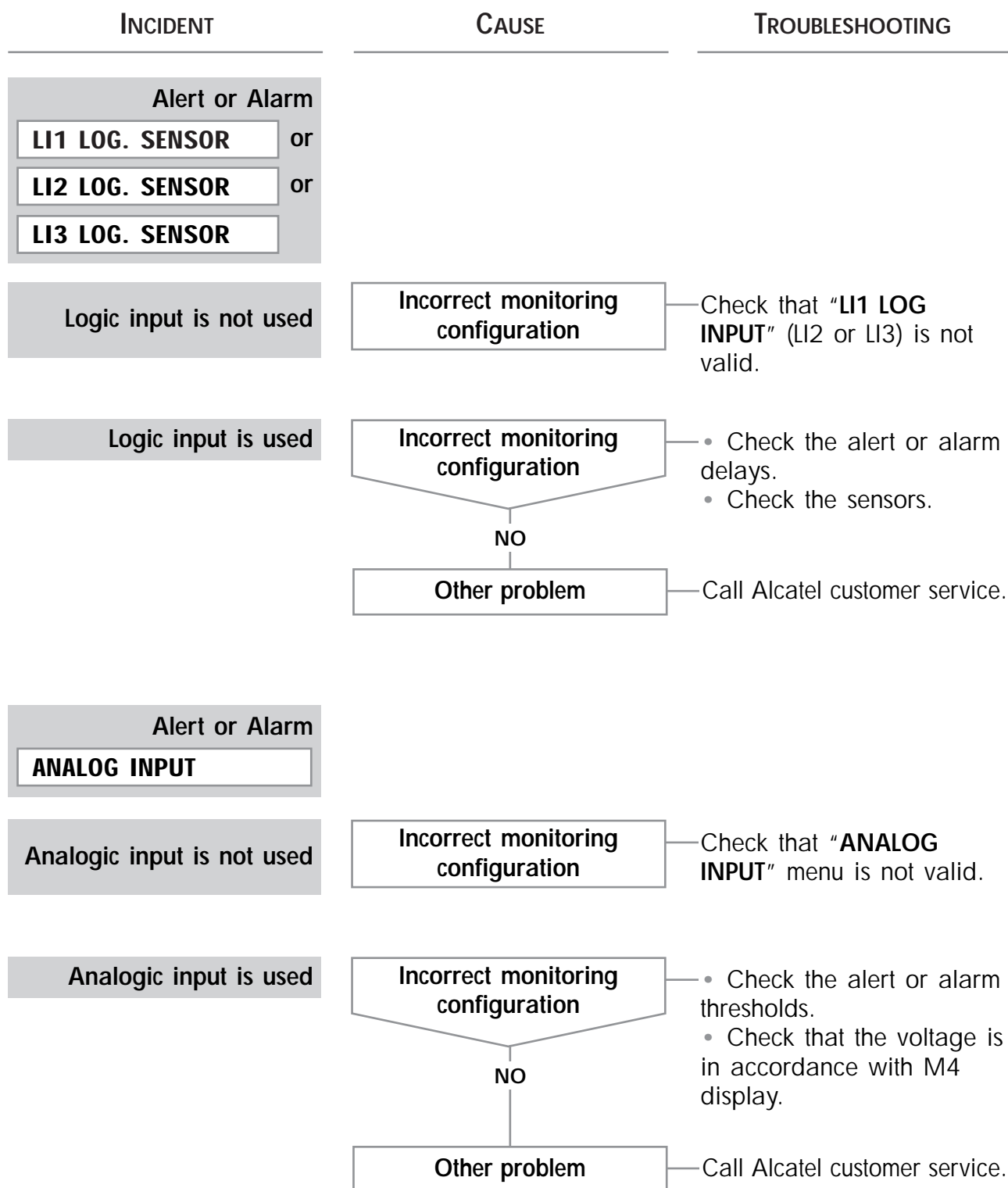

The pump is running - No message

INCIDENT	CAUSE	TROUBLESHOOTING
<p>Bad vacuum or no vacuum</p>	<p>Polluted or clogged pump</p>	<p>Maintenance ADP. Call Alcatel customer service.</p>
	<p>NO</p> <p>Internal oil leak</p>	<p>Maintenance ADP. Call Alcatel customer service.</p>
<p>Mechanical noise</p>	<p>Damaged ball bearing</p>	<p>Maintenance ADP. Call Alcatel customer service.</p>
	<p>NO</p> <p>Rotors seizing</p>	<p>Maintenance ADP. Call Alcatel customer service.</p>
	<p>NO</p> <p>Unsynchronized gears</p>	<p>Maintenance ADP. Call Alcatel customer service.</p>
<p>No N2 purge</p>	<p>Incorrect configuration</p>	<p>Reset M4 configuration (PURGE CMD enabled) or set the purge manually (PURGE key on hand held remote control).</p>

User's Manual ADP/ADS Series Two

Maintenance sheet

■ Pump draining	■ E 10
■ Exhaust maintenance	■ E 20
■ Freeing up the ADP	■ E 30
■ Resetting maintenance parameters	■ E 40

Pump draining

 Study the safety precautions before intervention.
(see D 00).

 Certain gases become corrosive and toxic when trapped in oil. Always wear protective gloves when handling used and dirty pump oil, drain into a closable container, and do not breathe the fumes of the oil.
Always use fully self-contained breathing apparatus.

 Always dispose of used or dirty oil, or sub-products properly and in compliance with all local, state and federal environmental laws and regulations.

Housing oil replacement

Unfasten the fill plug (1) in order to eliminate any excess pressure in the housing.



Remove the drain plug (2) and allow the used oil to flow into a container (capacity: 0.5 litre).

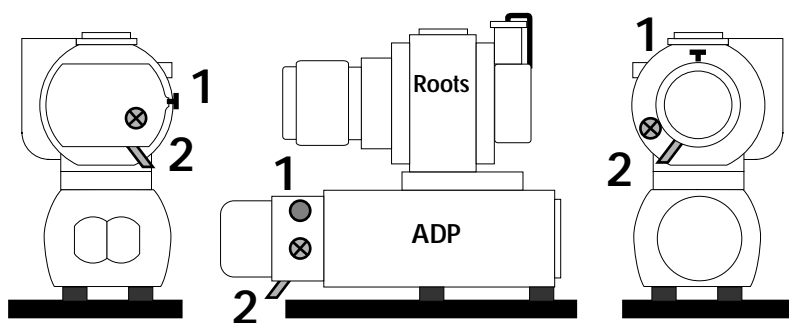

Caution: the Roots is equipped with 2 housings.
Repeat the operation for each housing.

Replace the drain plug (2) and then remove the fill plug (1).
Introduce the quantity of new oil required (see B 40).
Replace the fill plug (1)

Exhaust maintenance



Study the safety precautions before intervention.
(see D 00).



When the exhaust is maintained (anti-suckback valve and pipes), avoid any contact with the reaction by-products (deposit powder..) strongly corrosive: wear gloves even a breathing mask.

Maintenance frequency

The maintenance frequency of the anti-suckback valve of the pump ADP depends on the process used. Refer to the maintenance frequency tables (see D 20).

Acces to the valve



Facilities at the rear (exhaust in horizontal position)

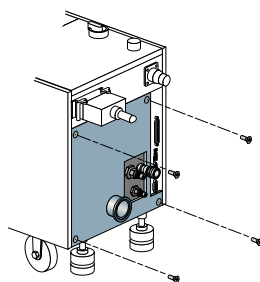

Remove the rear cover unscrewing the 4 screws. Anti-suck back valve is located under the pump.

Facilities on top (exhaust straight up)

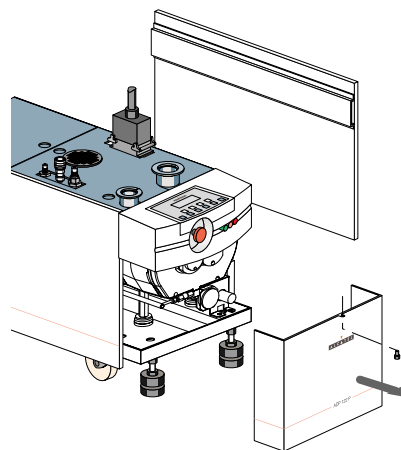

Remove the front cover and the right side cover. Disassemble the two quick connect clamps and centering ring maintaining the 3 exhaust pipes (straight up and bent). Remove the exhaust pipes.

Exhaust maintenance

Anti-suckback valve disassembly



Partly unscrew the 4 screws (1) maintaining the flange.
Remove the flange (2) by turning it anti-clockwise.
Remove the anti-suckback valve (3) and the spring (4).

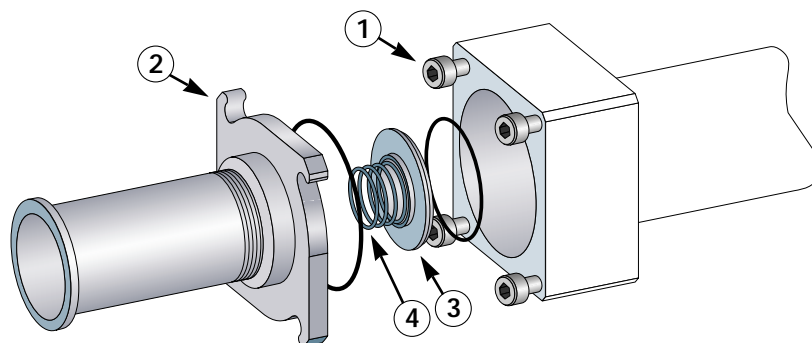

Part cleaning

Clean the metal parts in a bath of hot water using a cloth if necessary.
Dry in the air or with compressed air.

Reassembly

The parts to be replaced are included in the **anti-suckback maintenance kit (P/N 106624)**.

Replace the anti-suckback valve o-ring (5) and flange o-ring (6) by new ones.
Reassemble the anti-suckback valve (3) on the spring (4) than on the flange.
Fit the flange (2) on the pump exhaust and secure the 4 screws.

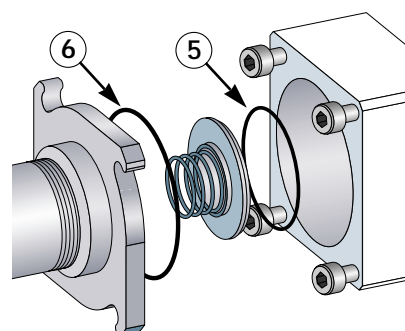

In case of straight-up exhaust :

Replace the o-ring of the centering ring.
Clamp the bent exhaust pipe and the straight-up with quick connect clamps.

Reassemble the pump covers.

Resetting maintenance counter

Reset the "INSPECT. EXHAUST" counter (see E 40).

Freeing up the ADP



Study the safety precautions before intervention.
(see D 00).

If, after a prolonged stop, the ADP does not restart using the function START because of sub-products deposited inside the pump, it is possible to free it up manually.



Remove the protective cover (1) and remove the O-ring by removing the three M4 x 10 CHc screws to get access to the Driving shaft.

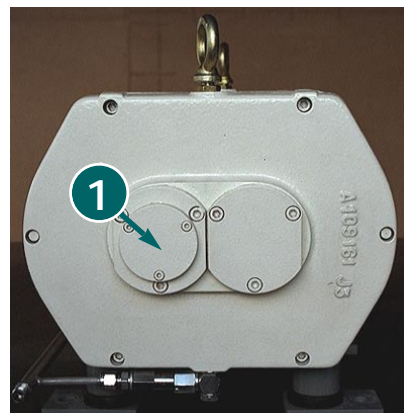

Using the box wrench, move the driving shaft in both directions of rotation until free rotation is obtained.

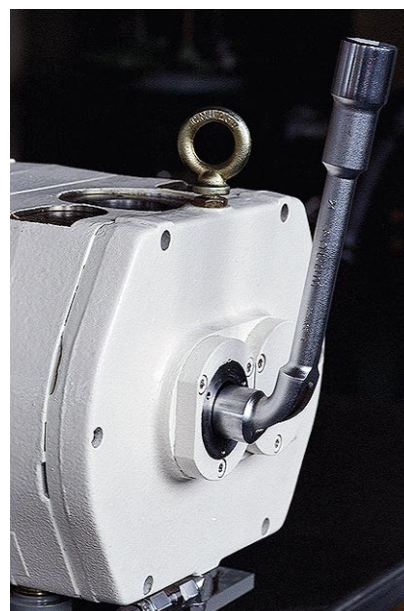

Clean the O-ring and grease it lightly with vacuum grease.
Reinstall the O-ring and the protective cover.
Restart the pump.

Resetting maintenance parameters

When the maintenance of an element has been done, **it is necessary to reset its meter to stop the warning** and reset the functional delay of this element.

Accessing the parameter programming

Press the key **SET**.

Press the key **+** and **-** until the code is obtained (Factory setting = 0).

Valid with the key **ENTER**.

ENTER PASSWORD :

CODE : 0

Access to chosen parameter menu

Press the key **+** repeatedly to access to **MAINTENANCE** menu valid with **ENTER**.

DEFINITION
SETTING MENU
>> **MAINTENANCE** <<
MANAGEMENT

Press the key **+** repeatedly to access to the chosen menu valid with **ENTER**.

ADP MAINTENANCE
ADP LP BEARING
>> **INSPECT EXHAUST** <<
ROOTS MAINTENANCE

The fresh screen appears.
Use the keys **+** and **-** to reset the duration to **0** .
Valid with the key **ENTER**.

COUNTER SET
>> **DURATION : 0 H** <<
MAXI : 65500 H
MINI : 0 H

Return to the main menu and exit the setting mode using the key **SET**.

France

Alcatel Vacuum Technology France
98, avenue de Brogny - BP 2069
74009 ANNECY Cedex
Tel : (33) 4 50 65 77 77
Fax : (33) 4 50 65 77 89

Germany

Alcatel HOCHVAKUUMTECHNIK GmbH
Am Kreuzeck 10
D - 97877 WERTHEIM
Tel : (49) 9342 9610-0
Fax : (49) 9342 9610-30

Italy

Alcatel Vacuum Systems S.p.A
Via Trento, 30
20059 VIMERCATE (MI)
Tel : (39) 039 686 3855
Fax : (39) 039 667 125

Japan

Alcatel ITS JAPAN
High Vacuum Technology Division
Ebisu MT Building 5 Floor
3-15-7, Higashi 3-Chome
Shibuya-ku, TOKYO 150-0011
Tel : (81) 3 5468 1621
Fax : (81) 3 5468 1603

Korea

Alcatel Vacuum Technology Korea
5th Floor, Sunghyun B/D
10-5, Karak-Dong, Songpa-ku
Seoul, SOUTH KOREA
Tel : (82) 2 409 6277
Fax : (82) 2 409 6279

United Kingdom

Alcatel Vacuum Technology (U.K.) Ltd.
8 Bain square Kirkton Campus - Livingston
West Lothian
EH54 7DQ SCOTLAND
Tel : (44) 1 506 418 000
Fax : (44) 1 506 418 002

USA

Alcatel Vacuum Products
67 Sharp Street
HINGHAM, MA. 02043
Tel : (1) 781 331 - 4200
Fax : (1) 781 331 - 4230

