



J-250 and J-260

Jitter and Timing Analyzers

Operator's Manual

September 2001





Corporate Headquarters

700 Chestnut Ridge Road
Chestnut Ridge, NY 10977-6499
Tel: (845) 578 6020 Fax: (845) 578 5985

Internet: www.lecroy.com

Copyright © 2001 by LeCroy. All rights reserved. Information in this publication supersedes all earlier versions. Specifications subject to change.

LeCroy, ProBus and SMART Trigger are registered trademarks of LeCroy Corporation. Mathcad is a registered trademark of MATHSOFT Inc. Centronics is a registered trademark of Data Computer Corp. Epson is a registered trademark of Epson America Inc. PowerPC is a registered trademark of IBM Microelectronics. MATLAB is a registered trademark of The MathWorks, Inc. DeskJet, ThinkJet, QuietJet, LaserJet, PaintJet, HP 7470 and HP 7550 are registered trademarks of Hewlett-Packard Company. I²C is a trademark of Philips. DRCG is a registered trademark of Rambus.

Manufactured under
an ISO 9000
Registered
Quality Management
System
Visit www.lecroy.com
to view the certificate.



This electronic product is subject to disposal and recycling regulations that vary by country and region. Many countries prohibit the disposal of waste electronic equipment in standard waste receptacles. For more information about proper disposal and recycling of your LeCroy product, please visit www.lecroy.com/recycle.





First Things First



Check That You Have Everything vii

Be Sure To Read This Warranty viii

Take Advantage of Maintenance Agreements viii

Obtain Assistance viii

Return a Product for Service or Repair viii

Stay Up-to-Date ix

Safety Symbols xii

Operate in a Safe Environment xiii

AC Power Source xiv

Power and Ground Connections xiv

Get to Know Your Jitter and Timing Analyzer Front Panel ... xvi

Jitter Timing Analyzer Controls xvi

Install and Power Up xx

Get to Know Your Jitter and Timing Analyzer Back Panel ... xxi

Initialize xxiii

Check Your Jitter and Timing Analyzer xxiii

Add an Option xxiv

Update to The Latest Firmware xxiv

Save The Screen (and energy) xxv

Do You Prefer Your Controls with Sound and Auto-Repeat? xxv

Introduction

J-250 and J-260 Jitter and Timing Analyzers xxvii

Getting Started xxx

Chapter 1 — The Measurement Tools

Taking Your First Measurements 1-1

Chapter 2 — The Analysis Tools

Jitter Analysis 2-1

Chapter 3 — Using JitterTrack™

How JitterTrack™ Tracks down Jitter 3-1

When to Use Jitter 3-3

Clock or Data? 3-6

Advance JitterTrack Setup and Configuration 3-8

Cycle-Cycle: Clock 3-12

Cycle-Cycle: Data 3-13

Duty Cycle 3-14

Timing Interval Error: Clock 3-15

Timing Interval Error: Data 3-16

Period: Clock 3-17

Period: Data 3-18



Half Period	3-19
Width.....	3-20
Frequency: Clock.....	3-21
Frequency: Data.....	3-22
Setup.....	3-23
Hold.....	3-24
Skew	3-25
Chapter 4 — Statistical Tools: Making Histograms	
Advanced Histogram Setup and Configuration.....	4-1
Applying Histogram Parameters	4-9
Using Cursors on Histograms.....	4-12
Chapter 5 — Applying Timing Parameters	
Advanced Timing Parameter Setup and Configuration	5-1
Chapter 6 —How to Use JitterFFT	
Chapter 7 — How to Use Phase Demodulation	
Chapter 8 — How to Trace Persistence	
To Trace Persistence.....	8-1
An Innovative Visual and Processing Tool.....	8-2
Set Up and Configure Per.Trace	8-3
Chapter 9 — How to Use Persistence Histogram	
How “Per.Hist” Reveals Hidden Features	9-1
Why Persistence Histograms and When.....	9-2
Set Up and Configure for Per.Hist	9-3
Chapter 10 — How to Plot Trends	
How to Use the Trend Tool.....	10-1
Set Up and Configure for Trends.....	10-2
Appendix A — More on Histograms and Trends	
Histogram and Trend Calculation	A-1

Appendix B — Histogram Parameters

Average	B-1
Full width at Half Maximum	B-2
Full Width at xx% Maximum	B-3
Histogram Amplitude	B-4
Histogram Base	B-5
High	B-6
Histogram Median	B-7
Histogram Root Mean Square	B-8
Histogram Top	B-9
Low	B-10
Maximum Population	B-11
Mode	B-12
Percentile	B-13
Peaks	B-14
Range	B-16
Sigma	B-17
Total Population	B-18
X Coordinate of xx th Peak	B-19

Appendix C — Remote Control Commands

Cursor	C-1
Function	C-4

Appendix D — Architecture & Specifications

Index



BLANK PAGE

WHEN YOUR INSTRUMENT IS DELIVERED

CHECK THAT YOU HAVE EVERYTHING

First, verify that all items on the packing list or invoice copy have been shipped to you. (The items are also listed below.) Contact your nearest LeCroy customer service center or national distributor if anything is missing or damaged. If there is something missing or damaged, and you do not contact us immediately, we cannot be responsible for replacement.

The following is shipped with the standard Jitter and Timing Analyzers:

10:1 10M ohm PP005 Passive Probe — one per channel

AC Power Cord and Plug

Performance or Calibration Certificate

Front Scope Cover

Two 6.3 A/250 V "T" Rated Fuses

J250/260 Operator's Manual

WavePro Operator's Manual

WavePro Remote Control Manual

Quick Reference Guide

Declaration of Conformity

CD ROM

NOTE: The warranty that follows replaces all other warranties, expressed or implied, including but not limited to any implied warranty of merchantability, fitness, or adequacy for any particular purpose or use. LeCroy shall not be liable for any special, incidental, or consequential damages, whether in contract or otherwise. The customer is responsible for the transportation and insurance charges for the return of products to the service facility. LeCroy will return all products under warranty with transport prepaid.

BE SURE TO READ THIS WARRANTY

The Jitter and Timing Analyzers are warranted for normal use and operation, within specifications, for a period of three years from shipment. LeCroy will either repair or, at our option, replace any product returned to one of our authorized service centers within this period. However, in order to do this we must first examine the product and find that it is defective due to workmanship or materials and not due to misuse, neglect, accident, or abnormal conditions or operation.

Spare and replacement parts, and repairs, all have a 90-day warranty.

The analyzer's firmware has been thoroughly tested and is presumed to be functional. Nevertheless, it is supplied without warranty of any kind covering detailed performance. Products not made by LeCroy are covered solely by the warranty of the original equipment manufacturer.

TAKE ADVANTAGE OF MAINTENANCE AGREEMENTS

We offer a variety of services under the heading of Maintenance Agreements. These give extended warranty and allow you to budget maintenance costs after the initial three-year warranty has expired. Installation, training, enhancements, and on-site repairs — among other services — are available through special supplemental support agreements. Inquire at your LeCroy customer service center or national distributor.

OBTAIN ASSISTANCE

Help with installation, calibration, and the use of your Jitter and Timing Analyzer in a range of applications is also available from your customer service center.

RETURN A PRODUCT FOR SERVICE OR REPAIR

If you do need to return a LeCroy product, identify it by its model and serial numbers (see page xliii). Describe the defect or failure, and provide your name and contact number.

For factory returns, use a Return Authorization Number (RAN), obtainable from customer service. Attach it so that it can be

clearly seen on the outside of the shipping package to ensure rapid forwarding within LeCroy.

Return those products requiring only maintenance to your customer service center. **Tip:** If you need to return your scope, use the original shipping carton. If this is not possible, the carton used should be rigid. The scope should be packed so that it is surrounded by a minimum of four inches (10 cm) of shock absorbent material.

Within the warranty period, transportation charges to the factory will be your responsibility, while products under warranty will be returned to you with transport prepaid by LeCroy. Outside the warranty period, you will have to provide us with a purchase order number before the work can be done. You will be billed for parts and labor related to the repair work, as well as for shipping.

You should prepay return shipments. LeCroy cannot accept COD (Cash On Delivery) or Collect Return shipments. We recommend using air freight.

STAY UP-TO-DATE

To maintain your Jitter and Timing Analyzer's performance within specifications, have us calibrate it at least once a year. LeCroy offers state-of-the-art technology by continually refining and improving the instrument's capabilities and operation. We frequently update both firmware and software during service, free of charge during warranty.

You can also install new firmware yourself, without the need to return it to the factory. Simply provide us with your Jitter and Timing Analyzer serial number and ID, and the version number of the software already installed, along with ordering information. We will provide you with a unique option key that has a code to be entered through the instrument's front panel to upgrade your software. In addition, the very latest versions of LeCroy's unique oscilloscope software applications can be downloaded from the Internet, free of charge. Included are ScopeExplorer and ActiveDSO.

ScopeExplorer is a highly practical PC-based connectivity tool that interfaces J-260 Jitter and Timing Analyzer to a PC that is running Microsoft Windows® via the rear panel GPIB (IEEE 488) or RS-232 port or Ethernet connector (optional). Specially designed by LeCroy for its products, ScopeExplorer allows you to

Jitter and Timing Analyzers

perform data and image transfers and other remote operations from scope to PC with just a few keyboard strokes or mouse clicks. See Chapter 12, "Use the J-260 Jitter and Timing Analyzer with a PC," for more about using ScopeExplorer with your J-260 Jitter and Timing Analyzer.

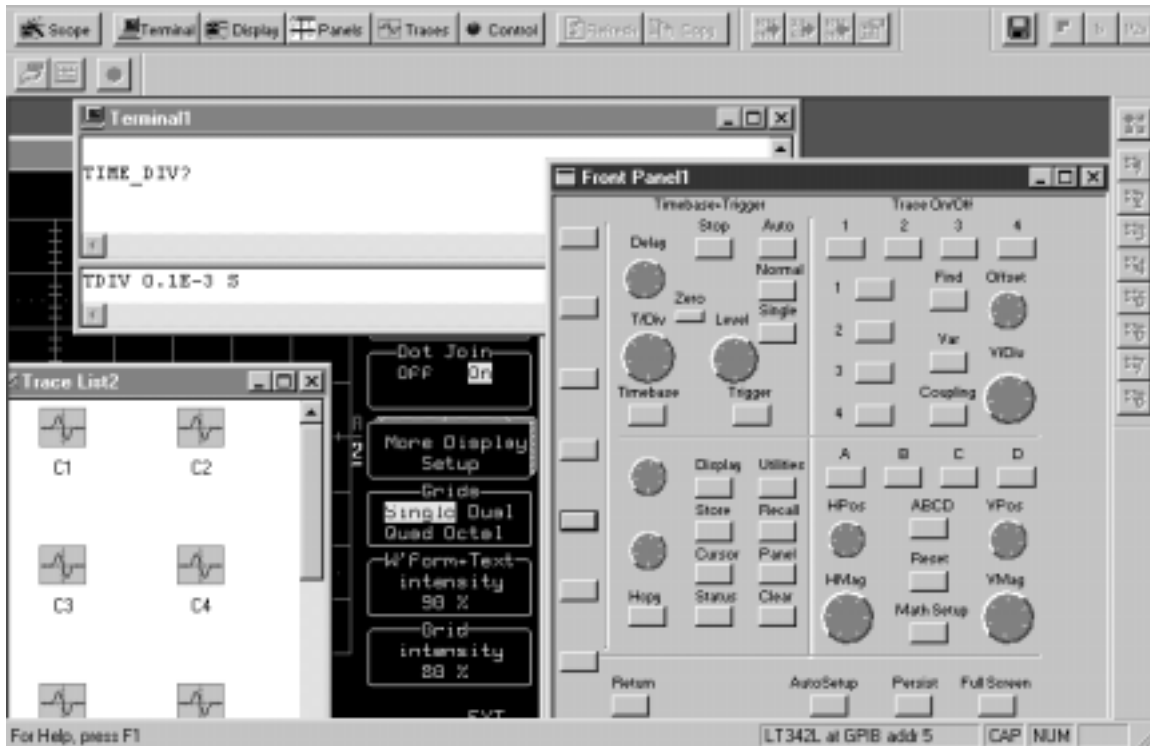

ScopeExplorer now has a virtual front panel to allow full control of remote scopes.

ActiveDSO, which works on any PC running Windows 95, 98, NT, 2000, or Me, enables you to exchange data with a variety of Windows applications or programming languages that support the ActiveX standard, such as MS Office, Internet Explorer, Visual Basic, Visual C++ and Visual Java. ActiveDSO hides the intricacies of programming for each of these interfaces and provides a simple and consistent interface to the controlling application. You can also visually embed ActiveDSO in any OLE







automation compatible client and use it manually without programming. You could, for example, generate a report by importing

scope data straight into Excel or Word, analyze your waveforms by bringing them directly into Mathcad, archive measurement results “on the fly” in a Microsoft Access database, and automate tests using Visual Basic, Java, C++, or Excel (VBA).

Visit our web site at <http://www.lecroy.com> to download these and other free software applications.

SAFETY SYMBOLS

Where the following symbols appear on the Jitter and Timing Analyzer's front or rear panels, or in this manual, they alert you to important safety considerations.

Symbol	Meaning
WARNING	Incorrect operation or failure to heed warnings may result in death or serious injury. If a WARNING is indicated on the instrument, do not proceed until its conditions are understood and met.
CAUTION	Incorrect operation or failure to heed cautions may result in injury or damage to equipment. If a CAUTION is indicated, do not proceed until its conditions are understood and met.
	Refer to accompanying documents (for safety related information). See elsewhere in this manual wherever the symbol is present, as indicated in the Table of Contents.
	Risk of Electric Shock
	Stand-by (Power) State
	Earth (Ground) Terminal
	Protective Conductor Terminal
	Alternating Current Only
	Chassis Terminal

OPERATE IN A SAFE ENVIRONMENT

The Jitter and Timing Analyzer is intended for indoor use only. Ensure that its operating environment will be maintained within these parameters:

- Temperature Range: 5 to 45 °C
- Humidity: 75% max. RH (non-condensing) up to 35 °C
Derates to 50% max. RH at 45 °C
- Altitude: 3000 m max. up to 25 °C
Derates to 2000 m max. at 45 °C

Note: This instrument has been qualified to the following EN 61010-1 category:

Protection Class	I
Installation (Overvoltage) Category	II
Pollution Degree	2



CAUTION

Do not block the air inlet or exit ports.



CAUTION

Do not allow any foreign matter to enter the instrument through air inlet ports, etc.



AC POWER SOURCE

Jitter and Timing Analyzers operate from a single-phase, 115 V (90 to 132 V) AC power source at 45 to 440 Hz, or 220 V (180 to 250 V) AC power source at 45 Hz to 66 Hz. Maximum power consumption: < 350 VA.

No manual voltage selection is required because the instrument automatically adapts to line voltage. The power supply of the analyzer is protected against short circuit and overload by two 5x20 mm fuses (T 6.3 A/250 V). See "Fuse Replacement."

Note: The instrument automatically adapts itself to the line voltage present within the following limits:

Voltage

Range: 100 – 120 VAC 200 – 240 VAC

Frequency

Range: 50/60/400 HZ 50/60 HZ

POWER AND GROUND CONNECTIONS

The Jitter and Timing Analyzer is provided with a three-wire electrical cord containing a three-terminal polarized plug for line voltage and safety ground connection. The plug's ground terminal is connected directly to the frame of the analyzer. For adequate protection against electrical hazard, this plug must be inserted into a mating outlet containing a safety ground contact.

Note: Set the power switch to STANDBY before connecting or disconnecting the power cord.



WARNING

Maintain the ground line to avoid electric shock. The power cord's protective grounding conductor must be connected to ground.

On/standby Switch

The On/Standby toggle switch controls the basic operational state of the analyzer. A portion of the analyzer will remain powered in the standby state (13 watts dissipation).

Power Off State

The analyzer can only be placed in a complete power off state by unplugging the analyzer's power cord from the primary power source (AC outlet). It is recommended that the analyzer's power cord be unplugged from the AC outlet during any extended period of analyzer inactivity.

Fuse Replacement

Set the power switch to STANDBY and disconnect the power cord before inspecting or replacing a fuse. Open the fuse holder (located directly to the left of the power receptacle) using a small, flat-bladed screwdriver. Remove the old fuse(s) and replace with new 5x20 mm fuses (T 6.3 A/250 V).

Calibration

The recommended calibration interval is one year. Calibration should only be performed by qualified personnel.

Cleaning

Clean only the exterior of your Jitter and Timing Analyzer, using a damp, soft cloth. Do not use chemicals or abrasive elements. Under no circumstances allow moisture to penetrate the analyzer. To avoid electric shocks, disconnect the instrument from the power supply before cleaning.

Abnormal Conditions

Operate the Jitter and Timing Analyzer only as intended by the manufacturer.

Do not operate the analyzer with covers removed. If you suspect the analyzer is damaged or has failed, immediately set the power switch to STANDBY and disconnect the power cord. Refer servicing to qualified personnel.



Up and Running

GET TO KNOW YOUR JITTER AND TIMING ANALYZER FRONT PANEL



Jitter and Timing Analyzer main front panel controls and features.

JITTER AND TIMING ANALYZER CONTROLS

Jitter and Timing Setup, Clock Zoom and Jitter Views Buttons:

- Setup** Invokes the Setup Wizard to allow automated setup of analyzer settings, jitter measurement type, and acquisition modes. Contains a “Start Acquisition” soft key to initiate clock or data signal acquisition.
- Clock Zoom** (toggle switch) Automatically displays magnified view of the single-ended or differential clock or data signal.

- Jitter Track** (toggle switch) Automatically displays a time vs. time display of a timing parameter based on the jitter-type selection made in the Setup Wizard, JitterTrack or Histogram menu.
- Histogram** (toggle switch) Automatically displays a statistical distribution of a timing parameter's set of values based on the jitter-type selection made in the Setup Wizard, JitterTrack or Histogram menu.
- Measure** (toggle switch) Automatically displays a set of measurement data for a pre-defined or user-defined group.
- Analysis** Displays a menu of analysis functions, and a list of analysis package options (if installed).





Special Features Buttons:

- Auto Setup** Automatically sets the scope's horizontal timebase (acquisition system), vertical gain and offset, as well as trigger conditions, to display a wide variety of signals.
- Analog Persist** Provides a three dimensional view of the signal: time, voltage, and a third dimension related to the frequency of occurrence, as shown by a color-graded (thermal) or intensity-graded display.
- Cursors** (toggle switch) Turns on cursors to measure signal details. Select from a wide variety including absolute and relative cursors, with readout in volts or dBm.

Channel Buttons:

- 1, 2, 3, 4** These buttons activate the menu that lets you change the channel's setup conditions including coupling, gain, and offset. They are used also to select multiple grids, to automatically set the gain (FIND), or to automatically display a zoom of the signal. Press twice to toggle the trace on and off.

Analysis Control Knobs:

-  **Position** Adjusts the horizontal position of a zoom trace on the display. The zoom region is highlighted in color on the source trace.
-  **Zoom** Adjusts the horizontal zoom (magnification factor) of the selected zoom trace.
-  **Position** Adjusts the vertical position of the selected zoom trace on the display.
-  **Zoom** Adjusts the vertical zoom (magnification factor) of the selected zoom trace on the display.



Analysis Control Buttons:

- A, B, C, D** Activates a setup menu for the selected zoom trace so you can select a source trace for the zoom: either a channel trace or another zoom trace. Press A, B, C, or D to set up signal processing, including averaging, integration, re-scaling, and other math (signal processing) functions. Press a second time to turn the trace off.
- Reset** Resets the zoom factors and clears the results from signal processing (math operations).
- Math Tools** Provides access and an overview of the setup of zooms and signal processing on all zoom traces.

Trigger Knobs:

- Level** Selects the trigger threshold level. The Level is indicated on the display grid and at the bottom of the screen.

Trigger Buttons:

- Setup** Activates the trigger setup menu to select the trigger type and the trigger conditions. Graphics shown at the bottom of the display indicate the trigger setup.
- Stop** Prevents the scope from triggering on a signal.
- Auto** Triggers the scope after a selectable time-out, even if the trigger conditions are not met.
- Normal** Triggers the scope each time a signal is present that meets the conditions set for the type of trigger selected.
- Single** Arms the scope to trigger once (single-shot acquisition) when the input signal meets the trigger conditions set for the type of trigger selected.

Horizontal Knobs:

- Delay** Horizontally positions the scope trace on the display so you can observe the signal prior to the trigger time. Delay adjusts the pre- and post-trigger time.
- Time/Division** Sets the time/division of the scope timebase (acquisition system). LeCroy SMART Memory automatically optimizes the memory and sample rate for maximum resolution.

Horizontal Buttons:

- Zero Delay** Sets the horizontal delay to zero. The trigger point is positioned at the start of the display grid.

Setup Activates the TIMEBASE menu to allow you to select acquisition conditions, including the sample mode, maximum memory length, external clocking, etc.

Vertical Knobs:

Offset Adjusts the vertical offset of the channel selected by pressing one of the Channels buttons (1, 2, 3, or 4).
Volts/Div Adjusts the Volts/Division setting (vertical gain) of the channel selected at the press of one of the "Channel" buttons (1, 2, 3, or 4).

General Control Buttons:

Panels Store scope setting files (Panels) to internal non-volatile virtual disk (VDISK) or to PC Cards and diskettes. These Panel files can be recalled to configure the scope to the previously stored settings.
Utility For setup of scope features including hardcopy devices and formats, date and time, mass storage devices, and remote control interfaces.
Display For setup of a wide variety of display characteristics including, X-Y mode, persistence, custom trace colors, bold data points, etc.
Wave Storage Store or recall waveform data to optional PC Cards or to a diskette.
Scope Status Displays the status of the scope including installed options, available memory, serial number, as well as most setup conditions including the acquisition system, and general waveform information.
Clear Sweeps Clears data from multiple sweeps (acquisitions) with the exception of the last acquisition including: persistence trace displays, averaged traces, FFT averaging, etc. During waveform readout, cancels readout.
Print Screen Prints the screen displayed to a diskette or to the optional: internal printer, PC Card Hard Drive, memory card, or network printer.

Soft Keys and Control Knobs:

Two control knobs linked to display screen These control knobs are context sensitive controls whose function depends on the feature selected. They are used to control measurement cursors, navigate through menus, and select items and conditions displayed in menus.

7 buttons linked to display These buttons are context sensitive buttons whose function

screen depends on the features selected and the menu displayed directly to the left of the buttons.

1 button with Return Icon This button returns the display to the previous menu, or clears the menu from the screen if the top-level menu is being displayed.

STANDBY Lamp: The STANDBY lamp indicates when the scope has placed itself in standby (screen saver) mode. In this mode, current settings are retained. The lamp does not indicate the standby mode that is induced when you turn off the power switch.

INSTALL AND POWER UP

1. Before powering up, check that the local power source corresponds to the Jitter and Timing Analyzer power range (see page).
2. Use the cable provided to connect the scope to the power outlet through its rear panel receptacle (see next page).
3. Turn the scope on by pressing the On button at the bottom left-hand corner of the Jitter and Timing Analyzer front panel.

Before a display appears, the instrument will automatically perform hardware and software self-tests, followed by a full system calibration. The front panel STANDBY LED will be lit during this sequence. The full testing procedure will take about 10 seconds, after which a display appears.

4. Press to display the UTILITIES on-screen menus.
5. Then press the button beside the menu to set the time and date.

GET TO KNOW YOUR JITTER AND TIMING ANALYZER BACK PANEL

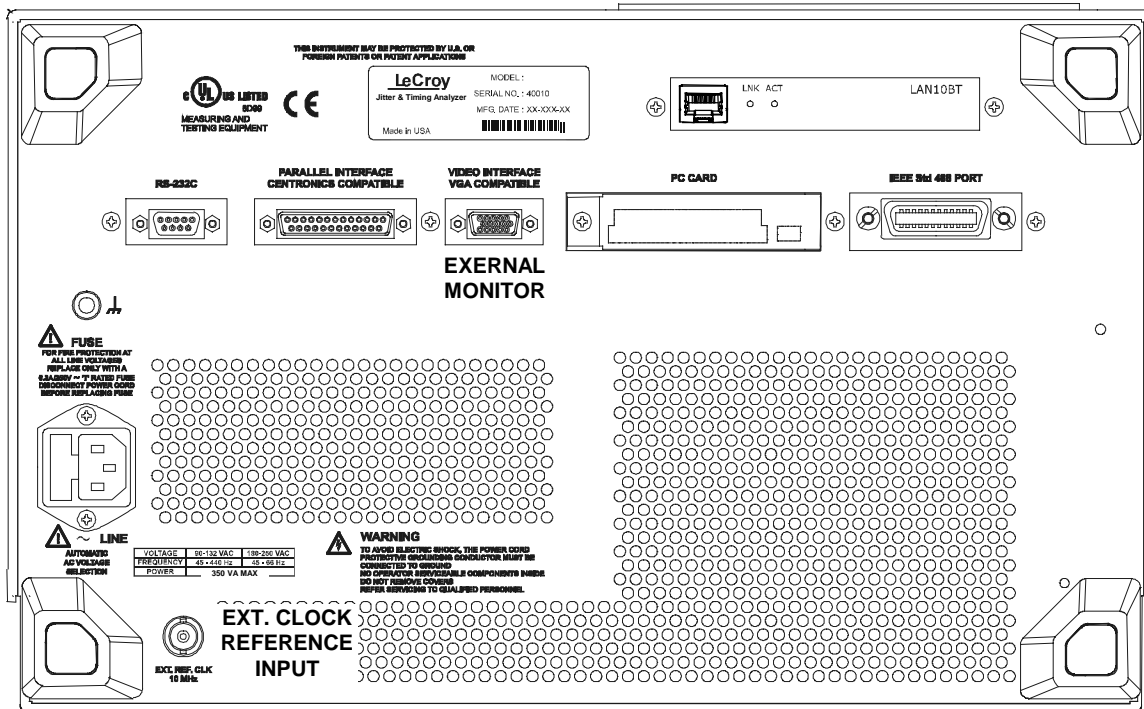

Use the RS-232-C, GPIB, and Ethernet ports to connect instrument to a computer or terminal, the external monitor port to display your waveforms on another monitor, and the Centronics port to connect compatible printers or other devices. Use the PC Card slot for the PC Memory Card and portable Hard Disk options, and the BNC input for external reference clock signal.

To NAVIGATE THROUGH MENUS

Menus such as  enable you to perform actions or adjust settings.



The **menu button** beside each displayed menu controls that menu.

Longer menus that span the breadth of two buttons are controlled by both buttons.

Capitalized menus —  for example — perform specific actions.

The **two menu knobs** work together with the two menu buttons beside them.

Combinations of knobs and buttons control continuously adjustable variables. The button selects or changes the variable, while the knob adjusts its value.



Menus are grouped and shown together according to their function. Press a button or turn a knob to select a particular menu or an item on a menu. Travel up or down in the menu list and change the selection. Or change values and settings.

PANELS

The **darker, labeled buttons** also play a role in menu selection:  — for example — was used to select the menus for initialization. When you press any one of these, it offers access to related menus in its group.

Menus with shadows  lead to other menus: Press their buttons to display those others.

Press  to return to a shadowed menu. Also use this button whenever you wish to go back to the previous menu display.

Arrows on the side of a long menu indicate that you can scroll up  or  down the menu list. Press one or the other of these menus' buttons to move in the desired direction, and to view or select any menu item not displayed. Arrows disappear when you reach the beginning or end of the menu list.

INITIALIZE

Initialize your instrument to its basic default waveform display settings:

PANELS

1. Press  to display the PANEL SETUP menu group.
2. If **Recall** is not selected, press the button once to select it:

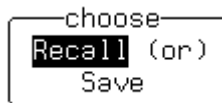

3. Then press the button beside

FROM DEFAULT
SETUP

Initialize to default settings whenever you wish to clear your settings and make a fresh start on a new measurement.

CHECK YOUR JITTER AND TIMING ANALYZER

SCOPE
STATUS

4. Press  to show the STATUS menus:

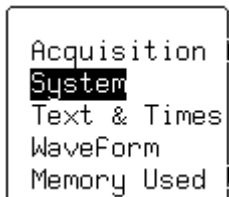

5. Press the top button to highlight and select **System**. The screen will show your Instrument's serial number, the version of software installed and the date of its release, as well as a full list of your currently installed software and hardware.

Contact LeCroy customer service immediately if any of the options you ordered have not been installed.



ADD AN OPTION

This menu will also be displayed when you select **System**:

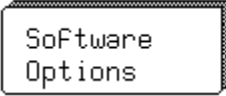

Software
Options

Use it to install new options — without the need to return your Instrument for a refit.

1. Press that menu's button to display

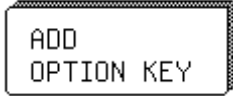

ADD
OPTION KEY

2. Then press that menu's button to display the ADD OPTION menus. Use them whenever you wish to add a Instrument option by means of a special code. Contact your LeCroy sales or service center to obtain the code.

UPDATE TO THE LATEST FIRMWARE

Your Instrument comes with the latest firmware installed. But to take advantage of our continuous improvement, contact us to obtain a floppy disk or card containing the latest firmware. Then use these menus to install it:

3. Press  to display the UTILITIES menus.

4. Press the button for



Special
Modes

for

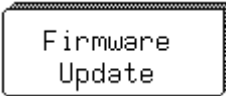

Firmware
Update

5. Place the floppy or card in the Instrument and press the buttons to select **Floppy** or **Card** and then Update Flash. The newly installed firmware will appear on the System Status screen (see above).

You may also download the firmware from the internet, using ScopeExplorer.

SAVE THE SCREEN (AND ENERGY)

Enable or disable your Instrument's screen saver:

DISPLAY

6. Press  to show the DISPLAY SETUP menus.
7. Press the button for "More Display Setup" to access this

menu:

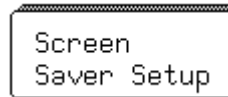

Screen
Saver Setup

8. Press its button, then select **Yes** or **No** from

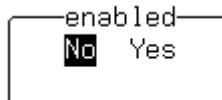

enabled
No Yes

When enabled, the built-in screen saver is activated 10 minutes after the last use of a front panel control. This is a complete display shutdown of the internal screen — an "Energy-Saver." The front panel LED light will indicate when the scope is in the screen-saving STANDBY state. Press any front panel button to restore the screen.

DO YOU PREFER YOUR CONTROLS WITH SOUND AND AUTO-REPEAT?

Have your buttons and knobs repeat their actions and make an audible sound when used:

UTILITY

9. Press  to display the UTILITIES menus. These you will find useful for a variety of functions.

10. Press the button for

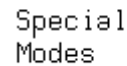

Special
Modes

, then the button for

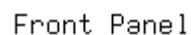

Front Panel

11. Make your preferences by means of the USER PREF'S menus displayed.

With Pushbutton auto-repeat **On**, all front panel buttons, when pressed and held in, will move the selection automatically and sequentially through all items in a menu.

With audible feedback for buttons and knobs **On**, an audible “click” will sound when any front panel button is pressed or any knob is turned.

§ § §



J-250 and J-260 Jitter and Timing Analyzers

The Jitter and Timing Analyzers are premium jitter and timing analysis systems for design and test engineers who regularly perform high-speed clock or datastream measurements and circuit timing analysis. The *Smart Jitter* software in Jitter and Timing Analyzers is an enhanced version of LeCroy's original JTA and JPRO packages. It has an easy-to-use Jitter Setup Wizard that configures the system for measurement type, input, and acquisition. This means that jitter measurement, viewing, and analysis can proceed easily and quickly with a minimum of additional operations.

Overview

Note:

J-250 or J-260 Jitter and Timing Analyzer

– the name of the complete hardware and software package.

Smart Jitter – the name of the software package in the Jitter and Timing Analyzers.

Setup Wizard – the part of the software that guides you through the process of setting up jitter or timing measurements.

Both analyzers contain a unique assortment of hardware and software features to maximize jitter measurement accuracy and repeatability, and to minimize the time spent in measurement setup. The optional AP-265 Differential and Single-Ended Edge Conditioner provides more accurate and repeatable measurements on a wide range of signals. The Jitter Setup Wizard permits fast, easy setup of the measurement so that viewing and analysis can proceed quickly. Setup is fast and flexible — at no point are you “locked out” from setting or changing any front panel controls. Advanced statistical, time, and numerical views of jitter are quickly available at the push of just one button. Jitter and timing measurements are conveniently grouped and displayed, also at the press of a single button.

Further spectral views or other analyses of jitter can also be easily selected and set up in the **Analysis** menu. The fast processing speed of the unit ensures minimum wait time, even when you're analyzing hundreds of thousands of clock edges with multiple jitter views displayed. In addition, the Jitter and Timing analyzers can also be used as regular digital storage oscilloscopes to view and analyze a wide variety of signals (reference the *WavePro Operator's Manual* for more information on its operation and capabilities as a DSO).



Viewing Capabilities

The *Smart Jitter* software package in the Jitter and Timing Analyzer provides views of jitter in three domains: statistical, time, and frequency. Numerical measurements are also calculated.

You'll get a much more complete picture of the signal because histograms are based on a statistically significant number of measurements (more than 700k, depending on clock rate) on larger samples (up to 32M).

Measurement parameters can be displayed in a number of different groupings, depending on whether you wish to perform statistical analysis on multiple acquisitions (Jitter Stat), jitter measurement on a single acquisition (Jitter Data), or analysis of the raw clock or data signal (Signal Integrity). It is easy to view 14 different clock, jitter, and statistical parameters with the push of a button. User defined parameters can also be set up in a "Custom" group.

The unique JitterTrack function is a time-vs.-time display of jitter. It clearly demonstrates the nature of jitter, and helps locate its source by making possible time-synchronized correspondences between jitter patterns and clock or data signals. These visible correspondences take the guesswork out of troubleshooting and debugging, and can be displayed on the screen with the push of two buttons.

The JitterFFT is an FFT (Fast Fourier Transform) of the JitterTrack. It provides a spectral view of frequency that isolates jitter from the rest of the signal to give an accurate picture of the problem. By determining and correcting the causes of timing variations at observed spectral values, peak jitter can be substantially lowered.

In addition to the above capabilities, you can phase-demodulate a clock signal to determine whether there is any amplitude, frequency, or phase modulation present (Phase Demod). You can also analyze a vertical or horizontal slice of a persistence map of multiple waveforms (Persistence Histogram), display data acquired from multiple sweeps of a waveform (Persistence Trace), or represent the evolution of timing parameters in line graphs (Trends).

New Capabilities

The analyzer includes new capabilities to measure half period jitter per JEDEC JESD-82.

Measurement Capability

The *Smart Jitter* software in the Jitter and Timing Analyzers provides measurement readout, jitter track, and histogram displays of the following measurement types:

Measurement parameters available

Single-Signal Measurements
<i>Clock</i>
Duty Cycle
Cycle-to-Cycle
N-Cycle
N-Cycle w/Start Selection
Frequency
Period
Half Period
Width
Duty Cycle Error (Delta width)*
Time Interval Error (TIE)
<i>Data Stream</i>
Cycle-to-Cycle
Frequency
Period
Time Interval Error (TIE)
<i>Two-Signal Measurements</i>
Clock Skew
Setup
Hold

* No JitterTrack provided.

Getting Started

Finding Your Way Around

The Display

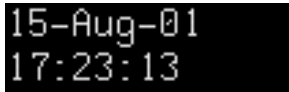

15-Aug-01
17:23:13

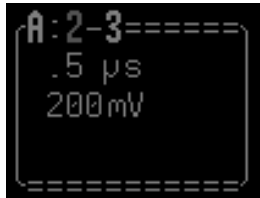

A: 2-3=====
.5 μ s
200mV

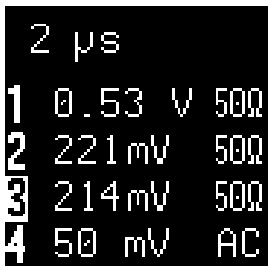

2 μ s
1 0.53 V 50 Ω
2 221mV 50 Ω
3 214mV 50 Ω
4 50 mV AC



← 20.0 μ s



8 GS/s
□ STOPPED

Upon initial boot-up, (or any time the default setup is recalled by pressing the front panel **PANELS** button and choosing **From Default Setup**), the screen of the Jitter and Timing Analyzer will appear.

Real-time Clock field – Powered by a battery-backed real-time clock, it displays the current date and time.

Displayed Trace Label – Indicates for each channel displayed the time/div and volts/div settings and cursor readings, where appropriate. In the analyzer, the Setup Wizard will automatically create a math Trace A that is the current acquisition, so that further zooming and other processing is easily enabled.

Acquisition Summary field – timebase, volts/div, probe attenuation, and coupling for each channel, with the selected channel highlighted. If the Setup Wizard was used to set up and perform the acquisition, the selected channel is the source channel in the Setup Wizard.

Trigger Point – an arrow indicating trigger time relative to the trace. If the Setup Wizard was used to set up and perform the acquisition, the trigger time is defaulted to 20 μ s before the display.

Trigger Status field – Shows sample rate and trigger re-arming status (AUTO, NORMAL, SINGLE, STOPPED). The small square icon flashes to indicate that an acquisition has been made. If the Jitter Setup Wizard was used to set up and perform a single acquisition, this will read STOPPED after the acquisition has been performed. If the Jitter Setup Wizard was used to set up and perform continuous acquisitions, this will read NORMAL and the square icon will flash each time a new acquisition occurs.

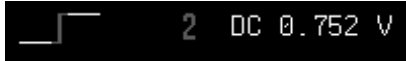

Trigger Configuration field – contains an icon indicating the type of trigger, and information on the trigger's source, slope, level, and coupling; and other information where appropriate. If the Setup Wizard was used to set up and perform the acquisition(s), the edge trigger type symbol with positive edge triggering (shown) will be displayed.



Trace and Ground Level – Shows the trace number or letter, and ground level marker. If the Setup Wizard was used to set up and perform the acquisition, the clock/data signal will be displayed as Trace A.

Other display areas include the Time and Frequency field (located below the grid) stating time and frequency relative to cursors, and a Message field placed above the grid and reserved for special messages.

For more about the display, reference the separate WavePro Operator's Manual.

Finding your Way Around The Front Panel

The Jitter and Timing Analyzer's front panel is very similar to that of any other Digital Storage Oscilloscope (DSO). Anyone familiar with the operation of a regular DSO will be familiar with many of the controls of the analyzer. However, the *Setup Wizard* simplifies many of the setup operations for acquiring and displaying the clock/data signal(s) so that you do not have to be familiar with a DSO in order to quickly acquire and display many different views of the clock/data signals, jitter, or analysis.



Jitter and Timing Analyzers

In the top half of the analyzer's front panel are typical setup and adjustment controls for Trigger, Horizontal, and Vertical settings. When the *Setup Wizard* is used to set up the acquisition and display of the desired clock/data signals, there is nothing in this panel that needs to be adjusted further in order to take jitter measurements, although you are not prevented from making any necessary adjustments. Reference the separate *WavePro Operator's Manual* for more information on these controls.



Next to the Vertical controls are the Channel pushbuttons. For any channel you would like to use for data acquisition, set the proper coupling by pressing the **CHANNEL** button, then selecting the **Coupling** menu with the soft key. There is no need to modify anything else in this menu. All other adjustments are done through the Setup Wizard.

Introduction

In the bottom half of the front panel are various general control buttons. If you are using the Setup Wizard to set up and perform your acquisition, there will be little need to ever use the **PANELS**, **UTILITY**, **DISPLAY** or **CUSTOM DSO** buttons. (Reference your WavePro *Operator's Manual* for more information on these buttons.) However, the **WAVE STORAGE**, **SCOPE STATUS**, **CLEAR SWEEPS**, and **PRINT SCREEN** buttons will be used more often. Familiarize yourself with these buttons and their menus.

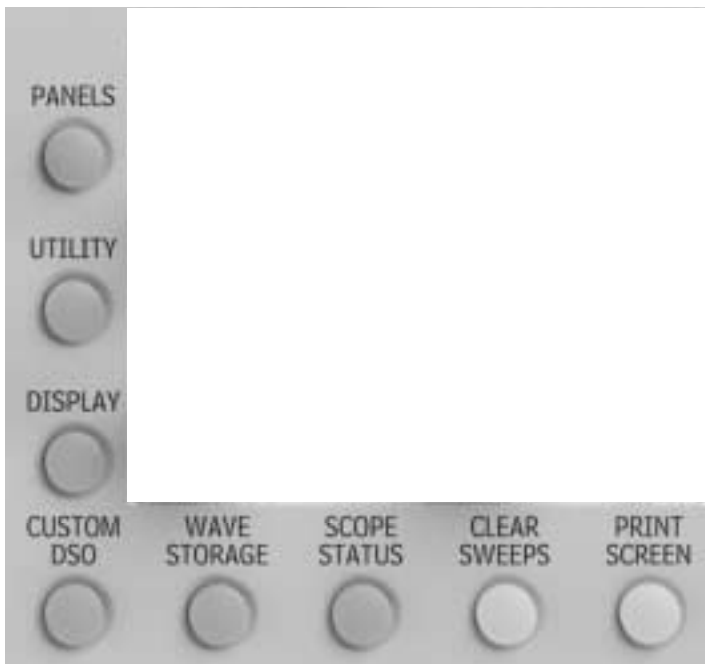

The Analysis Control section allows you to control the full power of the LeCroy Jitter and Timing Analyzer. The **ZOOM** and **POSITION** knobs allow you to zoom in vertically or horizontally to see waveform detail, or to position waveforms in ways that allow easy analysis. For instance, the analyzer allows the clock signal and JitterTrack of the clock signal to be displayed at the same time. The **ZOOM** knobs permit you to zoom horizontally and vertically to view the detail you



Jitter and Timing Analyzers

want. The **POSITION** knobs permit you to overlay the waveforms and look at a time-synchronized display of the clock/data signal and the jitter from edge to edge to more easily find the source of errors. The **RESET** button allows you to quickly reset all zoom and position controls to the default values. Get familiar with the **ZOOM** and **POSITION** knobs and the **RESET** button, and you will enjoy the full power of the LeCroy analyzer. The **A**, **B**, **C**, and **D** trace buttons are not needed unless you wish to use the analyzer for advanced setups or analysis.

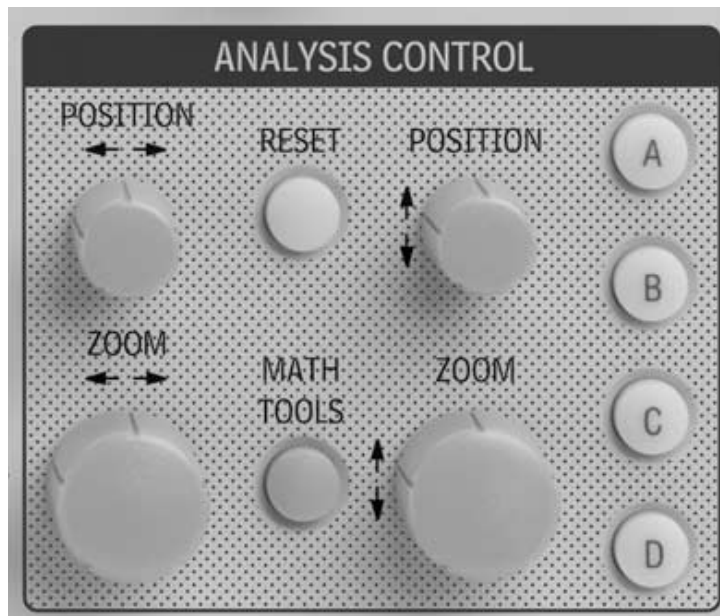



The Jitter and Timing **SETUP**, **CLOCK** and **JITTERVIEWS** buttons on the right-hand side of the analyzer permit you to quickly and easily access powerful analyzer capabilities. The exact functions of the buttons are defined in the next chapter. Note that the **JITTERTRACK**, **HISTOGRAM**, and **MEASURE** buttons in the Jitter Views grouping permit you to quickly display an advanced view of jitter with the push of one button once the clock/data acquisition is completed.

In summary, as a Jitter and Timing Analyzer user performing jitter timing and analysis measurements, you should spend most of your time using knobs and buttons in the Analysis Control section, and using Jitter and Timing **SETUP**, **CLOCK ZOOM**, and **JITTERVIEWS** buttons as well as another grouping of “special features” buttons comprising **AUTO SETUP**, **CURSORS** and **ANALOG PERSIST**. The most data and analysis with the least amount of setup will be available in these sections.

Using the Jitter Setup Wizard

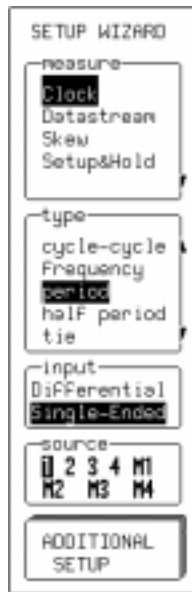

Taking your first measurements using the Setup Wizard in the analyzer is easy. The Setup Wizard is configured so that *every adjustment that must be made to ensure accurate, repeatable measurements is done automatically by the software*. You need only input what type of measurement you wish to perform, the type of input signal, the source of the input, and the type and length of the acquisition. All analyzer setup and display of clock/data information is performed automatically when you select **Additional Setup** → **Start Acquisition**.

First, press the **SETUP** button on the front panel. Then, connect your signal(s) to the appropriate inputs on the analyzer. If you are measuring jitter on a single signal, you may connect it to any channel. If you are measuring jitter on multiple signals (for instance, Skew, Setup, or Hold between two signals, or you are measuring a differential clock without using a differential probe or the optional AP-265 Differential and Single-ended Edge Conditioner box), follow the instructions in the Setup Wizard menu for connecting your signals to the analyzer.

The first of two Setup Wizard menus appears as shown at left. This first menu allows you to select the signal type and desired jitter measurement in the **Measure** and **Type** menus, and allows



Jitter and Timing Analyzers

you to select the type and source of the input signals. The second of the two Setup Wizard menus is accessed when you press the **Additional Setup** soft key.

This menu allows you to modify the default measurement setup (if desired) and also permits you to set the acquisition mode and length. The **Start Acquisition** soft key initiates acquisitions, which then permits additional statistical, measurement, time, or frequency analysis.

Once the signal is acquired, it is assumed that additional jitter measurements or views are desired. These views are easily accessed by pressing the **JITTERTRACK**, **HISTOGRAM**, or **MEASURE** buttons in the Jitter Views button group. Additional analysis capability to allow debugging or tracking of jitter problems can be accessed by pressing the **ANALYSIS** button.

An example of a display that you can quickly create is shown below:

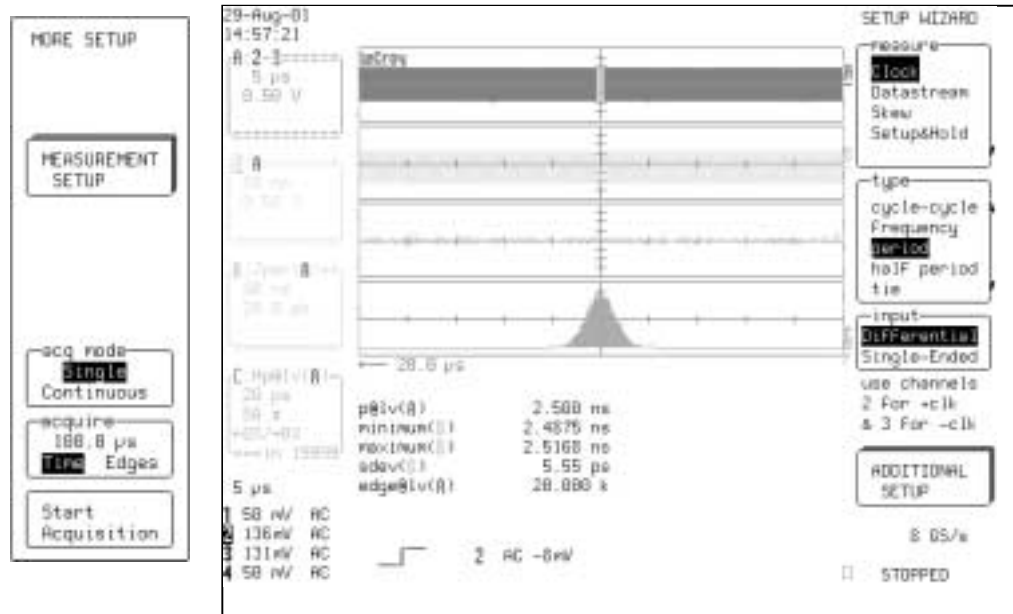

The top trace, Trace A (orange), is the raw clock trace that was acquired after the Setup Wizard **Start Acquisition** soft key was pressed.

Trace D (light green) is a zoom of the raw clock trace that was displayed after the **CLOCK ZOOM** button was pressed.

Trace B (rose) is a JitterTrack measuring the Period jitter of the raw clock trace. This display is time synchronized with the zoom of the clock trace to allow easier location of clock/data edges with high jitter.

Trace C (blue) is a Histogram showing the statistical distribution of the Period values in the raw clock acquisition.

Below all the traces are measurement values for Jitter Data, displayed with statistics.

More information on creating these displays and interpreting the results is contained in the chapters that follow.

§ § §



BLANK PAGE

Taking Your First Measurements

Setup Wizard:

The Setup Wizard is a unique capability of the Jitter and Timing Analyzer. It performs the requisite scope setup chores while simplifying measurement procedures to a few menu selections or button pushes. It also greatly simplifies display of the various time, statistical, numerical and spectral views of jitter, and maximizes the accuracy and repeatability of the scope. However, the Setup Wizard in the analyzer does not prevent you from operating any of the front panel controls if, at any time, you feel you must make non-standard settings or perform custom operations.

Before starting your measurements, it may be helpful to quickly verify that the clock or data signals are live and present at the input to the scope. To do this, press the front panel **AUTO SETUP** pushbutton. This will display the signals and verify that your probing or cable setup is correct before you proceed with measurements. If the signal does not appear satisfactory, adjust the coupling, probe, connection, etc. and press **AUTO SETUP** again.

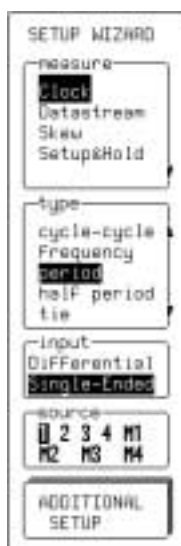

Setup Wizard menu 1 of 2



Setup Wizard menu 2 of 2

In the “Setup Wizard” menus, you may make selections in any order and move between menus to complete the selections. Changes made in the first menu, and in the “Measurement Setup” menu, will result in a new display

calculation. However, nothing will happen to the currently displayed clock or datastream acquisition (Trace A) until you press the **Start Acquisition** soft key on the second menu. If you exit the Setup Wizard at any time (by pressing the **RETURN** button once from the first menu, or by pressing a front panel button that brings up a new menu), and then re-enter, all previous settings will have been saved as the default settings. The same is true if you power the unit OFF and then ON again.

Setup Wizard Menu 1

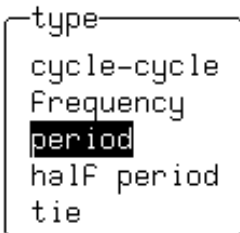
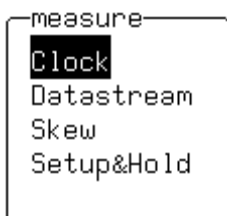

In the first Setup Wizard menu, the measurement type and input must be selected.

1. **Measure** – From the **measure** menu, select one of the following signal measurement types:
 - **Clock** (single clock line)
 - **Datastream** (telecom, datacom signals)
 - **Skew** (skew-type measurement on two clock instruments or on identical data streams on different pins)
 - **Setup/Hold** (data-clock relationship)

To make your selection, use the soft keys to the right of the menu box to toggle up or down through the menu.

2. **Type** – The **Type** menu is a listing of jitter measurement types that can be performed on the clock or datastream signal.

The selection in this list will control the selection of jitter measurement types whenever a JitterTrack or Histogram is displayed, and whenever measurements are active and either the Jitter Data or Jitter Stat groupings are displayed. If you are unfamiliar with the various jitter measurement types, refer to Chapter 3 for more information.

Here is the complete list of jitter types:

- **Duty Cycle**
- **Cycle-Cycle (with n-cycle selection)**
- **Frequency**
- **Period**
- **Half Period**
- **Time Interval Error**



- **Width**
- **Skew**
- **Setup**
- **Hold**

The list of jitter measurement types is context sensitive based on the selection in the **Measure** menu. For instance, if **Datastream** is chosen in the **Measure** menu, choices for **Cycle-cycle**, **Frequency**, **Period**, and **Width** jitter would appear. Different choices appear if **Clock** or **Setup & Hold** are chosen from the **Measure** menu. If **Skew** is chosen, there is no **Type** menu at all, since there is only one choice.

To make a selection, use the soft keys to the right of the menu box to toggle up or down through the menu.

3. **Input** – If you have chosen **Clock** or **Datastream** in the **Measure** menu, this menu will appear. If you have a single line coming into the scope, or are using a differential probe, select **Single-Ended** from the **Input** menu. For two lines going into the scope, choose **Differential**. If you are using the AP-265 Differential and Single-Ended Edge conditioner, follow the on-screen directions for use.

If you have selected **Skew** or **Setup&Hold** from the “measure” menu, this menu will not appear since you must connect the clock and/or data signals as described by the on-screen prompts.

Note:

For skew-type measurements, use Channel 2 for the clock reference and Channel 3 for the second clock. The reference clock must be of equal or higher frequency than Clock Two. If it is not, make clock 2 the reference clock.

To make a selection, use the soft key to the right of the menu box to toggle through the menu.

4. **Source** – This determines the channel(s) that the analyzer is receiving signals from.

If you have selected **Clock** or **Datastream** from the **Measure** menu and **Single-Ended** from the input menu, this menu will appear. Select Channels 1, 2, 3, or 4 or Memory 1, 2, 3, or 4 (M1, M2, M3, or M4). The Memory selections make it easy

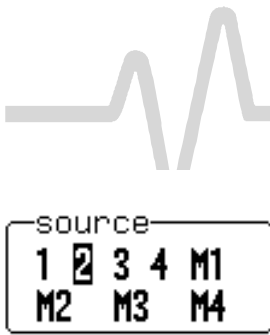

to swap data files with other LeCroy users, or recall old clock/datastream signal acquisitions for later analysis. Waveforms can be loaded into memories by pressing the **WAVE STORAGE** button on the front panel. For instructions on how to do this, refer to the *WavePro Operator's Manual*.

If you have selected **Skew** or **Setup & Hold** from the **Measure** menu, this menu will be replaced by instructions for hooking up the two signals to Channels 2 and 3. For example, when you select **Setup & Hold** from the **Measure** menu, you will be instructed to use Channel 2 for the clock reference and Channel 3 for data.

5. To access the second Setup Wizard menu, press the soft key to the right of **Additional Setup**.

Setup Wizard Menu 2

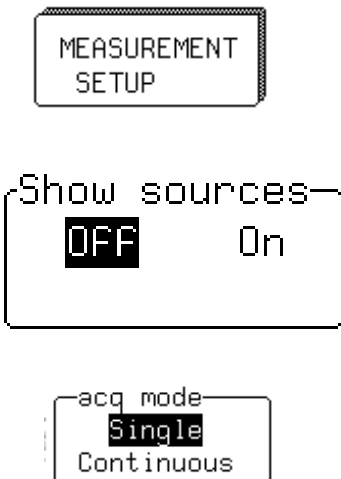

In the second Setup Wizard menu (labeled **More Setup**), you must adjust the specifics of the measurement and acquisition, then **Start Acquisition** to capture signal data.

1. **Measurement Setup** – This allows you to set the level at which the jitter measurement is made, and whether it is made from the positive or negative edge. (Cycle-cycle, half period, and TIE have additional settings for this parameter). Two-signal functions such as setup, hold, and skew allow you to set level and polarity for each signal (polarity can be set to positive, negative, or both).
2. **Show Sources** – This menu selection appears if you chose a differential input in the previous menu. **Showing Sources ON** will display the differential CK and CK BAR Sources in addition to the A (CK – CK BAR) trace.
3. **Acq(uisition) Mode** – This determines whether the analyzer is going to capture one long clock or signal acquisition for detailed analysis, or continually acquire and accumulate statistical data on multiple acquisitions.

Select **Single** if you wish to make one acquisition and then perform multiple analyses on it. Select **Continuous** if you wish to accumulate data from more edges than can be acquired in one acquisition at the maximum sampling rate. You may also select **Single** and manually trigger multiple

times (using the front panel **SINGLE** button in the trigger area) to accumulate a larger data set for statistical analysis.

Note:

The LeCroy Jitter and Timing Analyzer has deep memory and short processing times. This allows operations that are not possible on other jitter measurement scopes, like synchronization of jitter and clock data, analysis of the clock or datastream for modulation effects, and capture of long records for large n-cycle evaluation. Therefore, you should always attempt to do your testing with a single long acquisition.

For instance, a J-260 analyzer with a 32 Mpts record length and sampling at 16 GS/s can capture a 2 ms long acquisition. If you are measuring a 50 MHz clock, that equates to 100,000 edges. If you are measuring a 266 MHz clock, that equates to over 500,000 edges.

The analyzer calculates and displays your data very quickly. As a typical example, for 50 MHz clock and 10,000 edges, it takes approximately 12 seconds to acquire and display the clock signal, a JitterTrack, and measurements.

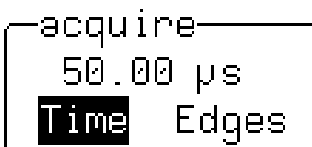

4. **Acquire** – This sets the total length of the acquisition to achieve the required sample size. The sampling rate is always kept at 16 GS/s (Single-ended) or 8 GS/s (differential) to maximize accuracy. Since the analyzer has deep memory, many edges can be acquired with one acquisition. If more edges are needed than can be acquired in a single acquisition, consider multiple acquisitions to achieve the required sample size.

Acquisition length may be set in either time or edges. The soft knob to the right of the menu controls the numerical value, and the soft key toggles between TIME and EDGES.

If TIME is selected, the time/div setting on the jitter analyzer will be set so as to result in the acquisition time desired. If EDGES is selected, the analyzer will sample the signal, determine the period, and set the acquisition to be of long enough time to include the required number of edges.

Note:

Since the time base of the analyzer has fixed settings, it is not possible to acquire the exact number of edges unless the clock frequently is a multiple of 1,2, or 5. If that is not the case, the



time base will be set to acquire more than the desired number of clock edges. You may then use the cursors to get measurement data on only the desired number of edges.

Start Acquisition

5. **Start Acquisition** – This initiates the acquisition by activating the analyzer's triggering. Press the soft key for **Start Acquisition**. The analyzer will acquire the clock signal and display it in Trace A as shown below.

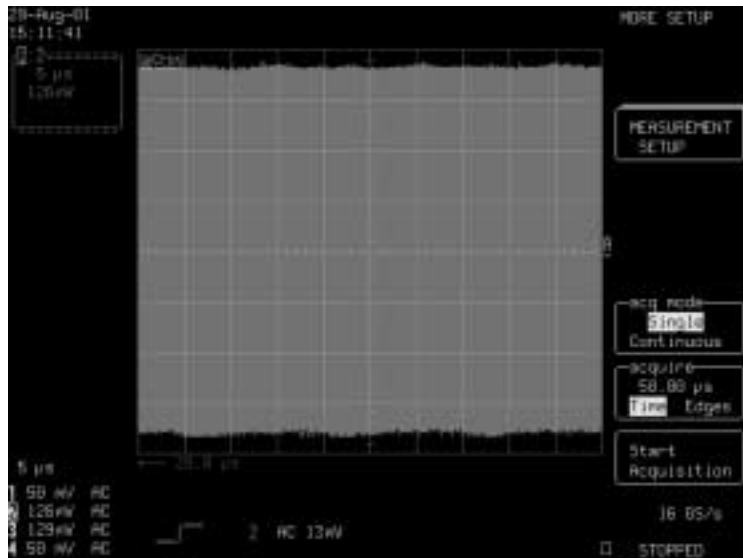

Note that in the case of differential inputs, the Trace A may not be maximized vertically. Since Traces A, B, C, and D have 16 bits of vertical resolution, measurement accuracy will not suffer.

You are now ready to do further measurement, views, and analysis.

Note: The front panel trigger button for **NORMAL** trigger performs exactly the same function as the **START ACQUISITION** soft key when ACQ MODE is set to **Continuous**. The **SINGLE** trigger button performs the same function as the **START ACQUISITION** soft key when ACQ MODE is set to **Single**. Using the trigger buttons can save time by not returning to the *Setup Wizard* menu if your setup has not changed.

Clock Zoom

Jitter measurement and analysis often require the acquisition of single, long record lengths with thousands of clock edges for analysis. LeCroy's SMART MEMORY provides the capability to do this quickly and easily. However, users of the long memory scopes often feel uncomfortable at not being able to see edge detail on a long memory acquisition.

LeCroy Clock Zoom solves this problem by providing the ability to quickly create a zoom on the clock trace to allow you to verify that the signal was acquired properly and was suitable for further measurement. In addition, the Clock Zoom allows easy synchronization of the JitterTrack with the clock signal. This enables determination and further analysis of the exact clock edge where high jitter was present.

To display the Clock Zoom trace on the screen, press the front panel **CLOCK ZOOM** button (located below the **SETUP** button) after you have displayed a clock signal on the screen. A second trace with 100:1 horizontal zoom factor will be automatically displayed on the screen. This trace will always be Trace D. If the horizontal zoom is not sufficient to resolve the clock edges (and it may not be on long memory acquisitions), adjust the front panel horizontal **ZOOM** knob until the resolution is sufficient for your needs.

The **Clock Zoom** menu will be displayed along with the trace. Pertinent sections of the menu are described below.



1. **Clock Zoom ON/OFF** – When the Clock Zoom button is pressed, this will be defaulted to ON. To turn it off, and not display the clock Zoom, press the Clock Zoom button again. To remove the Clock Zoom ON/OFF menu from the screen, press the Return button at the bottom-left of the front panel.
2. **Multi-Zoom ON/OFF** – When only the Original Clock Signal (trace A) and the **CLOCK ZOOM** Trace (Trace D) are displayed, this control permits zooming of the traces to be synchronized (**MULTI-ZOOM** ON) or unsynchronized, with only the **CLOCK ZOOM** being affected by changes to the front panel horizontal **ZOOM** knob (**MULTI-ZOOM** OFF).

If other Jitter Views are displayed (i.e. JitterTrack, Histogram, Jitter FFT, etc.), then the Multi-Zoom control affects all displayed traces except Trace A and the Trace C Histogram.

3. **Overlay Grids** – Superimposes all displayed traces on one large grid. If you wish that the A Trace not be superimposed, simply use the **A** button to turn it off.
4. **Play/Reverse Menus** – Scrolls the zoom trace across the screen. When playing, the menu is labeled STOP.
5. **Scroll By** – Scrolls by divisions per second or number of divisions. Use the soft key to the right of the menu to toggle back and forth. Use **div/s** to scroll continuously for viewing. Use **Number of Divisions** for waveform processing.
6. **Speed** – The soft knob to the right of the menu is used to set the scroll speed.

If a Clock or Datastream signal is being measured, the **clock zoom** will be a zoom of the clock or datastream signal being measured.

If you are performing skew measurements between two signals, the **clock zoom** will be zoom of the Clock Reference input to Channel 2.

If you are performing setup or hold measurements between clock and data, the **clock zoom** will be a zoom of the Clock Reference input to Channel 2.

Reference Chapter 1 of the WavePro *Operator's Manual* for more information on the menus displayed for **CLOCK ZOOM**.

Note:

The **Multi-Zoom** feature in the Jitter and Timing Analyzer differs somewhat from that of the WavePro. For instance, the trace labels for Trace A (clock signal) and Trace C (Histogram) will always have dotted top and bottom edges, even though they are not always multi-zoomed. In addition, the **Multi-Zoom** menu will always display Trace A as being included in the multi-zoom, even if it is not. Furthermore, the Histogram (Trace C) will only be zoomed if it is the last trace button pressed. If you do not want the Histogram to zoom with your time and frequency domain traces, simply press **JITTERTRACK** or **CLOCK ZOOM** first before using the **zoom** control.

Jitter Views Toolbar

The Jitter Views Toolbar provides fast, easy access to jitter views, measurements, and analysis. Once you have acquired your signals, this toolbar makes it easy to display time, statistical, measurement, or spectral views of jitter quickly. In addition, certain other functions are performed automatically as new views are added, such as modification of the display to allow viewing of all the waveforms.

If you have not already acquired and displayed signals using the Setup Wizard, do so now (accessed by pressing the **SETUP** button directly over the Jitter Views group of buttons).

JitterTrack

The JitterTrack Function/display is a time-vs.-time display that charts the evolution of these waveform attributes:

- **Duty Cycle**
- **Cycle-cycle deviation (including n-cycle with Start selection)**
- **Frequency**
- **Period**
- **Half Period**
- **Time Interval Error**
- **Pulse Width**
- **Skew**
- **Setup**
- **Hold**

For instance, **JitterTrack** of Period charts the timing error of the period of a signal compared to the average period of the signal. The timing error is displayed in the vertical scale, and the horizontal scale remains synchronized with the original clock or data signal. This allows easy determination of sources of high jitter by comparing the JitterTrack to the original signal.

To learn more about **JitterTrack**, refer to Chapter 3.

To display the **JitterTrack** for the type of measurement that you selected in the Setup Wizard, simply press the **JITTERTRACK** button. The **JitterTrack** will be displayed, along with the menu

shown at left. In most cases, you will not need to modify anything in this menu. The menu items are described below:



1. **JitterTrack ON/OFF** – When the **JITTERTRACK** toolbar button is pressed, this will be defaulted to ON. To turn it off, and not display the **JitterTrack**, press the **JITTERTRACK** toolbar button again. To remove the **JitterTrack ON/OFF** menu from the screen, press the **RETURN** button at the bottom-left of the front panel.
2. **Find JitterTrack** – Under certain conditions, the **JitterTrack** may not be correctly scaled, or may not be displayed. Pressing the soft key to the right of **FIND JITTERTRACK** will scale and/or display the **JitterTrack**. If the **JitterTrack** is still not displayed, make sure the measurement level is set correctly.
3. **MultiZoom & Auto Scroll** – This provides the capability to modify the zoom presets, and also to scroll through the waveform at a user-specified speed. The zoom default is to synchronize the **JitterTrack** with the clock signal. Access this menu only if you wish to change the default, or if you wish to perform scrolling. Reference your *WavePro Operator's Manual* for more information on **MultiZoom** and **Auto Scroll**.
4. **More Jitter Setup** – Allows advanced JitterTrack setup to be easily accessed, if necessary. Generally speaking, you should not need to access this menu. Reference Chapter 3 for more information on the items in this menu.
5. **Type** – This menu duplicates information in the *Setup Wizard's* Type menu. This makes it easy to change the **JitterTrack** measurement without having to go back to the *Setup Wizard*. This is extremely helpful if, after acquiring a signal, you wish to measure different types of jitter on the same signal, such as period, half period, and cycle-cycle.

To make a selection, use the soft keys to the right of the menu box to toggle up or down through the menu, or use the soft knob to scroll through the menu.

6. **Source** – This menu duplicates information in the Setup Wizard's Source menu. This makes it very convenient to connect clock or data signals to each channel of the analyzer, then simply switch between those signals to quickly view jitter measurements and views without having to return to the *Setup Wizard* menu.

Note:

The selection made in the **Type** menu will change the Type selection in the *Setup Wizard*, and will also change the relevant settings for histograms and measurements to ensure that all time, statistical, and measurement data is consistent for one type of jitter measurement. If you do not wish for this to be the case, you will have to use **ADVANCED SETUP**. Refer to Chapter 3 for more information.

The same is true of the selection made in the **Source** menu.

Histogram

The Histogram **Function/display** plots the statistical distribution in value of the following timing parameters:

Duty Cycle	duty @ lv
Duty Cycle Error	Delta wid @ lv
Cycle-Cycle	Delta p @ lv
Frequency	freq @ lv
Period	p @ lv
Half Period	hperj @ lv
Time Interval Error	tie @ lv
Width of Pulse	wid @ lv
Skew	skew
Setup	setup
Hold	hold

The histogram bar (horizontal) axis is divided into intervals, or bins. The height of each bar in the plot is proportional to the number of data points contained in the bin. The higher the bar, the more points there are in the bin and in the area of the waveform that it represents.

The distribution of the data (whether it is random or deterministic) can provide invaluable information for determining the source of the jitter.

To learn more about Histograms, refer to Chapter 4.

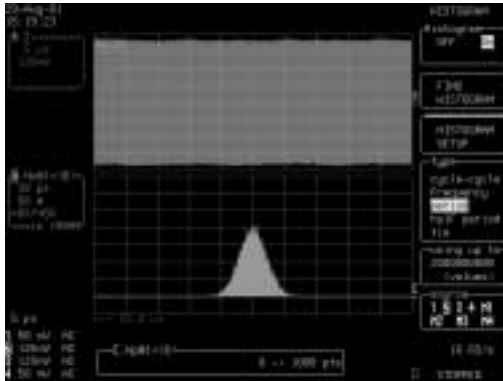

To display the Histogram for the type of measurement that you selected in the *Setup Wizard*, simply press the **HISTOGRAM** button. The Histogram will be displayed, along with the menu displayed at the left and described below:

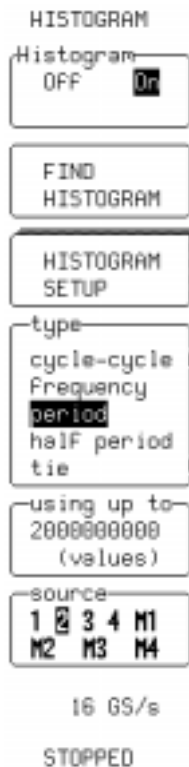

1. **Histogram ON/OFF** – When the **HISTOGRAM** toolbar button is pressed, this will be defaulted to **ON**. To turn it off, and not display the Histogram, press the **HISTOGRAM** toolbar button again. To remove the **Histogram ON/OFF** menu from the screen, press the **RETURN** button at the bottom-left of the front panel.
2. **Find Histogram** – Under certain conditions, the Histogram may not be correctly scaled, or may not be displayed. Pushing the soft key to the right of **FIND HISTOGRAM** will scale and/or display the Histogram. If the Histogram is still not displayed, make sure that the measurement level is set correctly.
3. **Histogram Setup** – Allows advanced Histogram setup to be easily accessed, if necessary. Generally speaking, you should not need to access this menu. Reference Chapter 4 for more information on the items in this menu.
4. **Type** – This menu duplicates information in the *Setup Wizard Type* menu. This makes it easy to change the Histogram measurement without having to go back to the *Setup Wizard*. This is extremely helpful if, after acquiring a signal, you wish to histogram different types of jitter on the same signal, such as period, half period, and cycle-cycle.

To make a selection, use the soft keys to the right of the menu box to toggle up or down through the menu.

Note:

The selection made in the **Type** menu will change the Type selection in the *Setup Wizard*, and will also change the relevant settings for **JitterTrack** and measurements to ensure that all time, statistical, and measurement data is consistent for one type of jitter measurement. If you do not wish for this to be the case, you will have to use **Advanced Setup**. (Refer to Chapter 4 for more information.)

5. **Using up to XXXX Values** – During continuous acquisitions, the Histogram will accumulate data up to the number set in this menu. The default value is the maximum (2 billion values) allowed by the software. You may adjust this lower if

you wish; however, when you turn the histogram off using the **HISTOGRAM** toolbar button, the value will automatically be reset to the default value.

If you wish to clear the values from the Histogram and begin acquiring new data, you may press the front panel **CLEAR SWEEPS** button at the lower-right of the front panel.

Measure

Measure allows you to gather quantitative data on the information contained in the various jitter views. The Jitter and Timing Analyzer makes this easy by providing custom measurement views specifically tailored to jitter measurements.

To display the Measurements at the bottom of the screen, simply press the **MEASURE** button. The Measurements will be displayed, along with the menu displayed at the right and

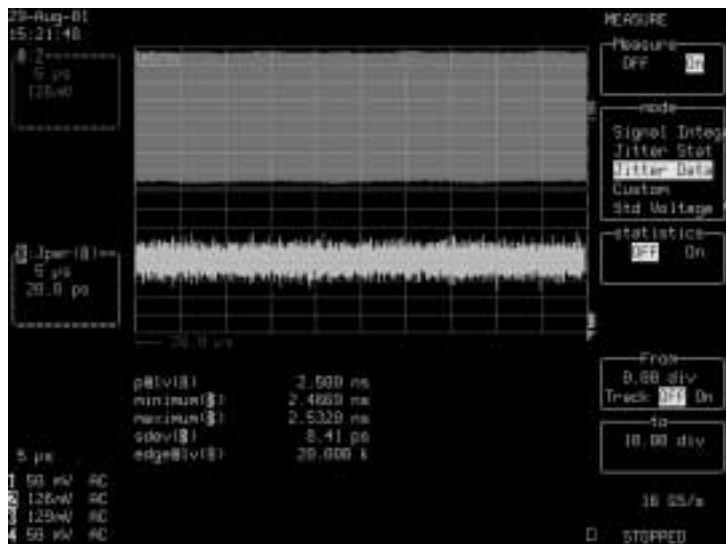

described below:

1. **Measure ON/OFF** – When the **MEASURE** toolbar button is pressed, this will be defaulted to ON. To turn it off, and not display the Measurements, press the **MEASURE** toolbar button again. To remove the Measure ON/OFF menu from

The Measurement Tools

the screen, press the **RETURN** button at the bottom left of the front panel.

Note:

All measurements can be “gated” so that measurements are only being performed on part of the time or frequency domain waveforms. It is important to realize when cursors are ON and gating measurements, so that you do not report erroneous results.

If a histogram is displayed, the cursors must completely enclose the histogram width if Jitter Stat measurement mode is selected. Otherwise, the histogram parameters in Jitter Stat will report incomplete information.

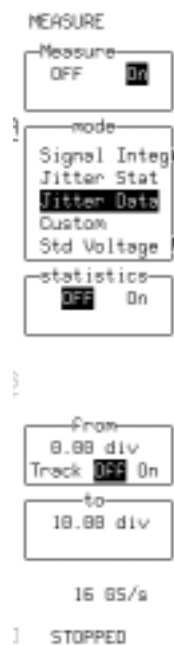

2. **Mode** – Lists various pre-defined measurement groupings, of which three (**Jitter Stat**, **Jitter Data**, and **Signal Integ**) are specific to jitter measurements. Other views list standard parameters in logical groups and allow you to determine which channel or trace should be measured.

The custom jitter measurement groupings are as follows:

Jitter Stat – Provides an average value of the timing parameter on the top line, and measurement statistics of data contained within the histogram display on the next four lines. **Jitter Stat** provides accumulated data from a single or continuous acquisition. It is generally used when it is desired to accumulate data over a number of acquisitions.

Definitions of the listed parameters are as follows:

Timing Parameter (A) – the relevant timing parameter based on the Type selection in the *Setup Wizard*, **JitterTrack**, or **Histogram** menus. Reference Chapter 5 for more information.

The timing parameter is shown with either an **(A)** or a **(2,3)** after it to signify the Trace or Channels it is measuring. Trace A is simply a copy of the clock or datastream signal. Channels 2 and 3 are the inputs for Skew, Setup, and Hold measurements.

Low (C) – The value of the leftmost populated bin in the histogram. This is not the lowest actual numerical value in the histogram.

The parameter is shown with a **(C)** in parentheses because it is being performed on Trace C, which is always defined, by default, as the Histogram.

High (C) – the value of the rightmost populated bin in the histogram. This is not the highest actual numerical value in the histogram.

Range (C) – The difference between the value of the rightmost and leftmost populated bins in the histogram.

Sigma (C) – The standard deviation of the data in the histogram.

Refer to Appendix B in the manual for more information about these parameters.

Jitter Data – Provides an average value of the timing parameter on the top line, and timing-related parameters for a single acquisition on the next four lines.

Definitions of the listed parameters are as follows:

Timing Parameter (A) – the relevant timing parameter based on the Type selection in the *Setup Wizard*, **JitterTrack**, or Histogram menus. Refer to Chapter 5 for more information.

The timing parameter is shown with either an (A) or a (2,3) after it to signify the Trace or Channels it is measuring. Trace A is simply a copy of the clock or datastream signal. Channels 2 and 3 are the inputs for Skew, Setup, and Hold measurements.

Minimum (B) – the lowest value of the timing parameter, as measured in a single acquisition of the **JitterTrack**. The parameter is shown with a **(B)** in parentheses because it is being performed on Trace B which, by default, is always defined as the **JitterTrack**.

Maximum (B) – the highest value of the timing parameter, as measured in a single acquisition of the **JitterTrack**.

Sdev (B) – the standard deviation of the timing parameter data in the **JitterTrack**.

Edge @ Iv (A) – the number of edges in the unzoomed clock for Trace A.

Refer to your *WavePro Operator's Manual*, Chapter 11, for more information on these parameters.

Signal Integrity – If a Clock or Datastream signal is being measured, this selection provides information about the clock or datastream signal being measured.

If you are performing skew measurements between two signals, it provides information on the Clock Reference input to Channel 2.

If you are performing setup or hold measurements between clock and data, it provides information on the Clock Reference input to Channel 2.

Rise (A) – the duration of the clock waveform's rising transition from 10% to 90%, averaged for all rising transitions between the cursors.

Fall (A) – the duration of the clock waveform's falling transition from 90% to 10%, averaged for all falling transitions between the cursors.

R20-80% (A) – the duration of the clock waveform's rising transition from 20% to 80%, averaged for all rising transitions between the cursors.

F80-20% (A) – the duration of the clock waveform's falling transition from 80% to 20%, averaged for all falling transitions between the cursors.

Pk-Pk (A) – the difference between the highest and lowest points in the waveform.

Custom – This menu contains temporary custom setups that are created by the user. These temporary custom

setups are overwritten whenever any of the above three measurement mode selections are made.

For information on defining the Custom parameter modes to suit your specific needs, refer to Chapter 11 in the *WavePro Operator's Manual*.

3. **Statistics** – Additional statistics can be displayed on each measurement by turning statistics ON.
4. **From/To** – All parameters can be “gated,” that is, they can be measured only between cursor values. This is very helpful if you wish to measure parameter values for only a certain number of edges.

The **From** menu defines the leftmost cursor. You can adjust it using the soft knob to its right. Use the soft key to select whether you want this cursor to move in unison (track) with the rightmost cursor, or not. The cursor position, in divisions, is displayed in the menu box.

The **To** menu displays the position, in divisions, of the rightmost cursor. The soft knob to the right of this menu adjusts the position of the rightmost cursor.

If cursors have Track ON, both cursors can be adjusted in unison with the leftmost cursor's soft knob.

Example:

Input a 400 MHz differential clock signal into the analyzer; start acquisition for 1,000 edges; display the **Clock Zoom**, **JitterTrack**, and **Histogram** for half period jitter. Also display **Measurements** (Jitter Data grouping). Notice that the edge @ Iv measurement shows 2,000 edges in the acquisition, but you only want to measure jitter on 1,000 edges.

If the **Measure** menu is not displayed, display it, and use the lower soft knob (to the right of the **To** menu) to move the rightmost cursor over to 5,000 divisions. The edge @ Iv reading is now 1,000 edges. Press **CURSORS** and turn **Reference Cursor Track** to **ON** (if **Track OFF/ON** isn't displayed in the **Measure** menu). Use the upper soft knob (to the right of the **From** menu) to select which 1,000 cycles you wish to measure (if desired), and read your results.

The Measurement Tools

Change Measure mode to Jitter Stat and read the results. If the cursors enclose the histogram, Low, High, and Sigma should be almost equivalent to Minimum, Maximum, and Sdev, respectively. If cursors don't enclose the histogram, these results will differ.

Note that the results will also differ if you have accumulated multiple acquisitions in the histogram (Minimum, Maximum, and Sdev only report data on the last acquisition).

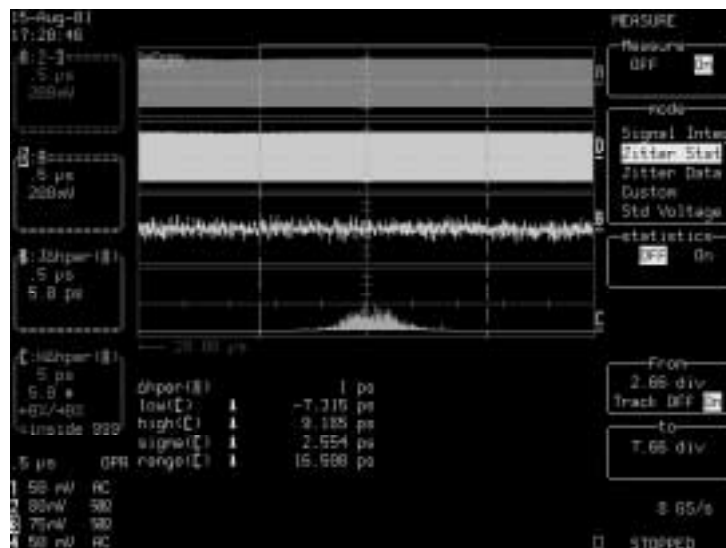

Now use the front panel **ZOOM** controls to adjust the horizontal zoom on the Clock Zoom (Trace D) and JitterTrack (Trace B) until you can see individual clock signals. Note that the Jitter Stat measurements are unaffected by the zoom adjustment. Switch to Jitter Data measurements and note that the minimum, maximum, and sdev measurements are affected by zooming.

Change the measure mode to Custom, select **CHANGE PARAMETERS**, and change parameter On-line 5 (edge @ lv) to be of the Clock Zoom (D) instead of the unzoomed clock (A) by adjusting the Source in the Of menu to D.

Jitter and Timing Analyzers

Note that the histogram display will not zoom unless it is the last function “touched.” If you do not wish to zoom the histogram, press the **CLOCK ZOOM** or **JITTERTRACK** buttons to display the menu; then perform the zoom.

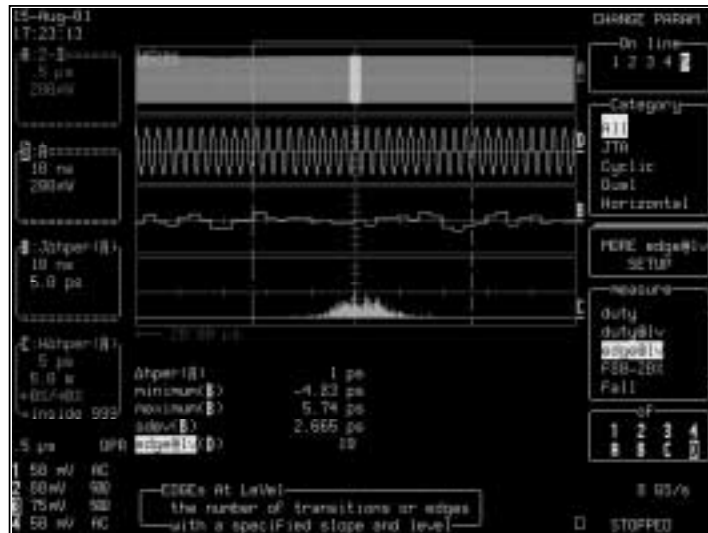

Now press the **JITTERTRACK** button to display the JitterTrack menu. Change Type to cycle-cycle. Notice how all the data is instantly recalculated and displayed. Display the measurement group you desire and take readings.

The Measurement Tools

Locate a jitter peak in the JitterTrack display. Position this peak in the center of the display using the front panel **HORIZONTAL POSITION** knob in the Analysis Control section. Use the front panel horizontal **ZOOM** knob to expand the zoom around this point until you can clearly see the clock edges and JitterTrack display. Reposition the zoom, if necessary, to the center and use the front panel **VERTICAL POSITION** knob in the ANALYSIS CONTROL section to overlay the JitterTrack and Clock Zoom. Since these two displays are synchronized, you can easily correlate high jitter to a specific clock edge.

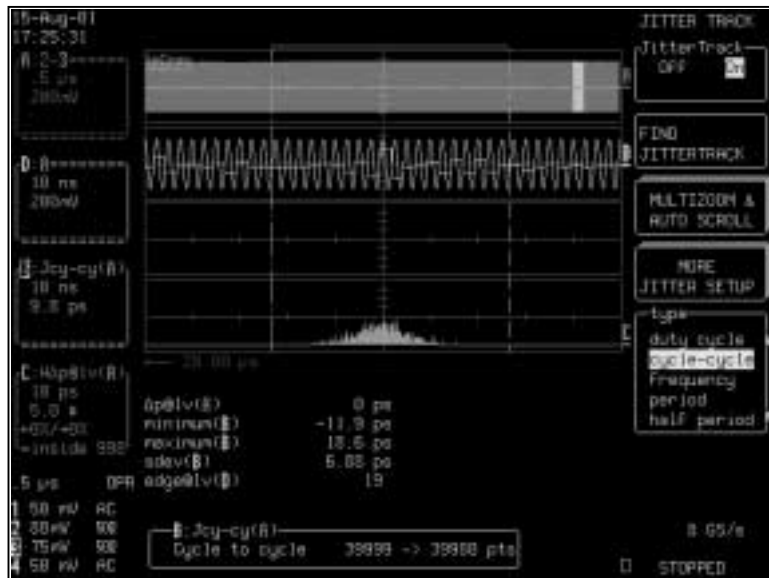

Done? Press the front panel **RESET** button in Analysis Control to return the display to an unzoomed state.

§ § §



BLANK PAGE

Jitter Analysis

Once you have acquired signal data and characterized the jitter using the various time, statistical, and measurement views available in the Jitter and Timing Analyzer, it is likely that you will need some additional analysis tools to locate sources of high jitter so that they can be eliminated.

The various analysis capability that is included or optional for the analyzer is briefly described below. Each analysis area has its own chapter with more detailed explanation.

Analog Persistence

Analog Persistence offers the advantages of analog display in a digital storage oscilloscope. The display looks like analog, and is fast, too. But it also has the data manipulation, flexibility, and statistical analysis capabilities only found in a digital instrument. Reference Chapter 9 of your *WavePro Operator's Manual* for more information.

Jitter FFT

Jitter FFT is the FFT of **JitterTrack**. This provides a spectral view of frequency that isolates jitter from the rest of the signal to give an accurate picture of the problem. By determining and correcting the causes of timing variation at observed spectral values, peak-peak jitter can be substantially lowered. Reference Chapter 6 for more information on setup and use.

Phase Demodulation

Demodulation is a **JitterTrack** display that measures the time difference between the edges of the acquired waveform relative to an ideal clock. It is ideal for extracting spread spectrum modulation frequency from a clock signal, or the analysis of communications systems employing continuous phase modulation as well as those using phase shift keying for transmitting digital data. Reference Chapter 7 for more information on setup and use.



Persistence Trace

Persistence Trace is a new concept for displaying the data acquired from multiple sweeps of a waveform. A vector trace is computed, based on the bit map of the underlying multiple signal acquisitions. Detail is then represented in a choice of three graphic forms, each representing a different characteristic of the waveform. Insight into edge details is given down to a few picoseconds — valuable in applications such as the examination of fast signal transitions. See Chapter 8 for more information on setup and use of Persistence Trace.

Persistence Histogram

Persistence Histogram analyzes a vertical or horizontal slice of a persistence map of multiple waveforms. The resultant bar chart shows a numerical measurement of the timing variations of a signal, which are observed qualitatively in the persistence display of the signal. A typical application is characterizing the jitter in a communications signal eye diagram. See Chapter 9 for more information on setup and use of Persistence Histograms.

Trends

Trends represent the evolution of timing parameters in line graphs whose vertical axes are the value of the parameter, and horizontal axes the order in which the values were acquired. Reference Chapter 9 for more information on setup and use. See Chapter 10 for more information on setup and use of Plotting Trends.

§ § §

How JitterTrack™ Tracks Down Jitter...

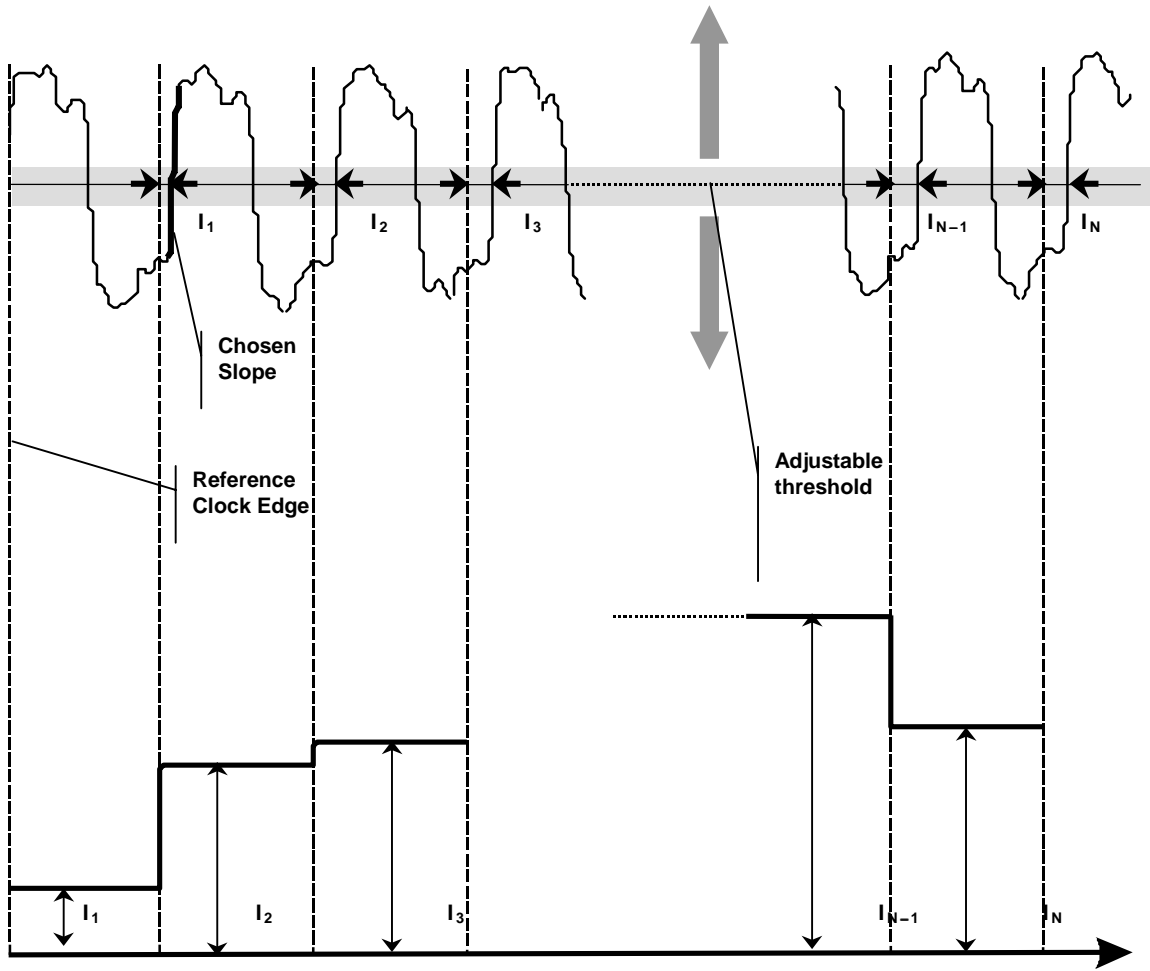

...Using Clock or Data

Use this function to plot as a bar chart the evolution over time of this and five other waveform attributes in simple steps. **Illustration this page:** How **JitterTrack's** Interval Error works when Clock Mode is selected; **Illustration next page:** When Data Mode is selected.

1. Set the desired reference clock frequency for an ideal position against which the signal is to be compared, or use "Find Frequency."
2. Specify the level at which the jitter measurement is to be made, as well as the rising or falling edge on which the measurement is to start.
3. Timing errors are graphically revealed.

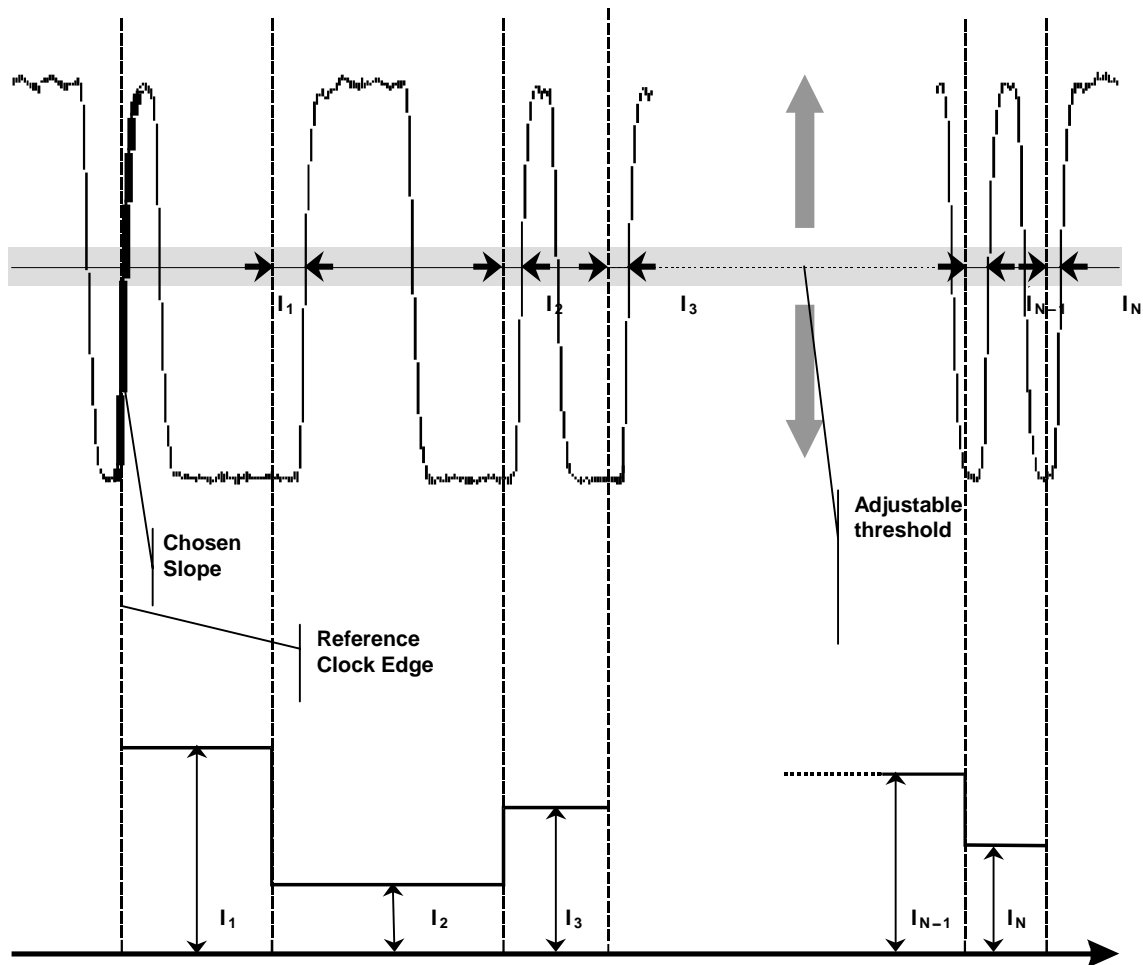

When to Use JitterTrack

The JitterTrack Function charts the evolution in time of these waveform attributes:

Cycle-to-Cycle deviation

Duty Cycle

Time Interval Error

Period

Half Period

Frequency

Width (Pulse)

Skew

Setup

Hold

Each is time-correlated to its source trace and contains the same number of points as the waveform.

JitterTrack or Trend?

Whether it is more appropriate to use **JitterTrack** or the statistical tool, Trend (described in Chapter 8), will largely depend on the application, as well as the other factors set out in the tables below. While **JitterTrack** sample points are evenly spaced in time, those of Trend are not. Trend plots any parameter available in the instrument against its event count, as in a scatter or an XY diagram.

Characteristic	Trend	JitterTrack
Representation	parameter value vs. events	attribute value vs. time
Attributes or Parameters Supported	All Parameters (See Chapter 11 of the instrument operator's manual for a complete list and description)	Cycle-Cycle Duty Cycle Time Interval Error Period Half Period Frequency Pulse Width



		Skew Setup Hold
Behavior	Cumulative over several acquisitions up to 20 000 events	Non-cumulative (resets after every acquisition) Unlimited number of events

When you need to...	Use...
Monitor the evolution of a waveform parameter or attribute over several acquisitions...	Trend — Jitter works only on one acquisition at a time
Time-correlate an event and a parameter value...	JitterTrack
Monitor an evolution in the frequency domain...	JitterTrack — Trend points are not evenly spaced in time and therefore cannot be used for FFT (Fast Fourier Transform).
Monitor parameters that are not specific to Jitter and Timing measurement	Trend

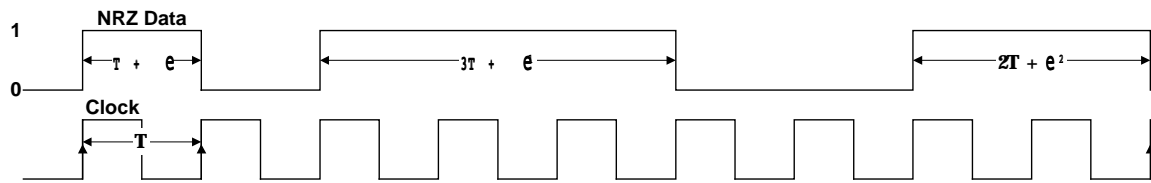

Random NRZ (Non-Return to Zero) data stream and its corresponding clock signal (see next page).



Clock or Data?

For most waveform attributes, JitterTrack offers the choice of **Clock** or **Data** modes for measuring clock signals or data streams. “Data” should be used — where available — when the pulse widths, intervals, periods or other significant instants being measured are randomly distributed and contain multiples of the clock period.

On the one hand, apart from jitter, clock signals ought to be regular. On the other hand, data streams by their very nature have irregular pulse widths.

A clock signal is normally required to characterize jitter. But such a signal will not be available if the waveform being measured is a data stream, whose very randomness hides the clock signal. To overcome this, **JitterTrack** provides both Clock and Data modes. Selecting **Datastream** from the *Setup Wizard Measure* menu, or **Data** from the **Type** menu in the math setup for **JitterTrack**, gives the superior timing resolution through normalization (see *below*) required for correctly measuring jitter in data signals.

The diagram on the previous page shows a data stream in relation to its clock signal. It illustrates how data pulses contain, within themselves, multiples of their clock-signal pulse widths. Analyzing the positive pulses in the data stream, we observe a great variance between each sample in, for instance, the range T to $3T$. In fact, it is the small variations (the jitter) that are important. And they could be normalized if clock frequency, and clock frequency over pulse width, were known. This normalization, provided by **JitterTrack**, reduces pulse variations and increases timing resolution so that errors (ϵ) can be clearly observed. It does this by reducing the jitter range, dividing each measurement equal to $n \times T$ by n .

Modes	CLOCK	DATA
Jitter Range	$3T + \epsilon$	$\epsilon \ll 3T$
Resolution	coarse	fine

Comparing a random data stream analyzed using Clock and Datastream/ Data modes.

Advanced JitterTrack Setup and Configuration

Quickly displaying a JitterTrack of a clock or data signal was already discussed in Chapter 1 when the operation of the JITTER VIEWS TOOLBAR was described. However, there are times when you may want to trade off the ease of use of the **JitterTrack** button for more flexibility. This section is intended to provide you with the detail on how to set up a JitterTrack, or multiple JitterTracks, on any of the Math Traces.



1. Press **MATH TOOLS** on the Jitter and Timing Analyzer front panel to display the **Zoom + Math** menus. They allow redefinition of any of the four traces A, B, C and D. Access their **Setup** menus. (Alternately, press the Trace **A**, **B**, **C**, or **D** button to access the **Setup** menu directly, and skip step 2 below).
2. Press the menu key for **Redefine A**, to configure the function — on Trace A for this example.
3. Select **Jitter** from the “Math Type” menu and use the menus shown here to configure any of the 10 *JitterTrack* types described on the pages that follow.

Use Math?

To choose a math function, in this case a **JitterTrack**.

Math Type

For selecting **Jitter**.

MORE JITTER SETUP

To access the **Jitter B** menu group (next page).

FIND JITTER TRACE

Scales **JitterTrack** automatically, once calculated. The instrument accumulates all timing values contained in the source waveform and then, when the corresponding menu button is pressed, automatically scales the **JitterTrack** to display the highest and lowest values that mark the limits of the range.

Type

For selecting one of **JitterTrack's** 11 waveform attributes, using the associated menu knob. And, where the chosen attribute allows it, to additionally select either the **Clock** or **Data** mode (see previous pages), using the corresponding menu button. Here, **Interval Error** and **Data** are chosen, and are used for the examples that follow.

Of

For selecting the source trace. This will default to the source chosen in the *Setup Wizard* menu, if the *Setup Wizard* was used.



The menus shown on this and the following pages are displayed when Interval Error is the selected waveform attribute and the menu button for **MORE JITTER SETUP** is pressed. Other JitterTrack functions may not display the same menus. However, the menus shown here, as well as their descriptions, are representative of those that serve all 11 attributes.

JITTER (Level):

JITTER **B**

scale in
UI **time**

FIND JITTER
TRACE

set
level
Frequency

SET INPUTS TO
MAX AMPL

level is
absolute
percent

level
50 %
Pos Neg

FIND
LEVEL

These menus appear when **level** is chosen from **set**, below.

scale in

Expresses the attribute in either **UI** unit intervals or seconds (**time**).

FIND JITTER TRACE

Scales **JitterTrack** automatically, once calculated.

set

Enables the choice of either **level** or **frequency** setup (see next page). When **level** is chosen, the menus below reflect this.

level is

Appears when **level** is selected from the **set** menu (see above). Determines whether the levels should be set in **absolute** – in volts – or as a **percent**(age) of signal amplitude.

SET INPUT TO MAX AMPL

If the source is a channel, pressing this button is equivalent to selecting VAR gain and pressing FIND, for the source channel. This maximizes SNR, which can improve measured jitter.

level

Appears when **level** is selected from the **set** menu (above), for selecting the voltage or amplitude-percentage setting of the level on the waveform at which the timing is to be measured. Also to select whether the measurement should be made on a **Pos**(itive or rising) edge, or a **Neg**(ative or falling) edge.

FIND LEVEL

Appears when **level** is selected from the **set** menu (above). Automatically finds and sets the threshold to the appropriate level.

JITTER (Frequency): These menus appear when **frequency** is chosen from **set**, below.

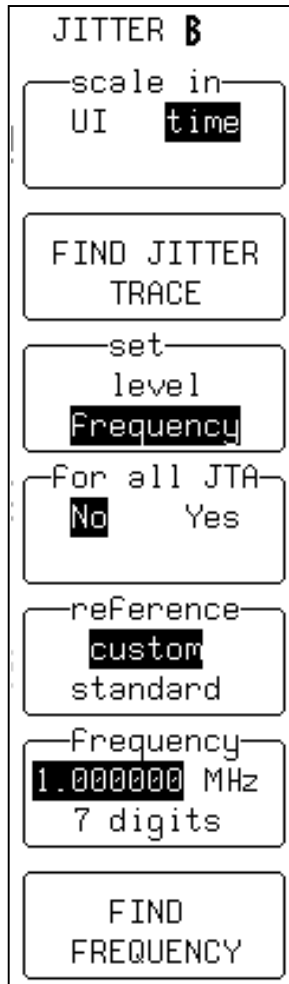

scale in

Expresses the attribute in either **UI** (unit intervals) or **time** (in seconds).

FIND JITTER TRACE

Scales **JitterTrack** automatically, once calculated.

set

Enables the choice of either **level** or **frequency** (see next page) setup. When **frequency** is chosen, the menus below reflect this.

For all JTA

Global effect: when **YES**, the frequency will apply to all jitter and timing parameters for which data is available.

reference

Enables the choice for the reference clock of either a **custom**, user-defined, frequency or selection from a list of **standard**, pre-defined, frequencies. The frequency is adjusted using the menu immediately below.

frequency

When **custom** is chosen from the **Reference** menu, a particular user-defined frequency can be selected. The corresponding button for this menu highlights either the mantissa, or the frequency decade or number of digits, while the associated knob changes the value highlighted. When **standard** is chosen, selection from a number of pre-defined frequencies can be made for the reference clock, using the menu button.

FIND FREQUENCY

Appears when **frequency** is selected from the set menu (above). Automatically detects frequency and sets the bit rate.



Cycle-Cycle: Clock

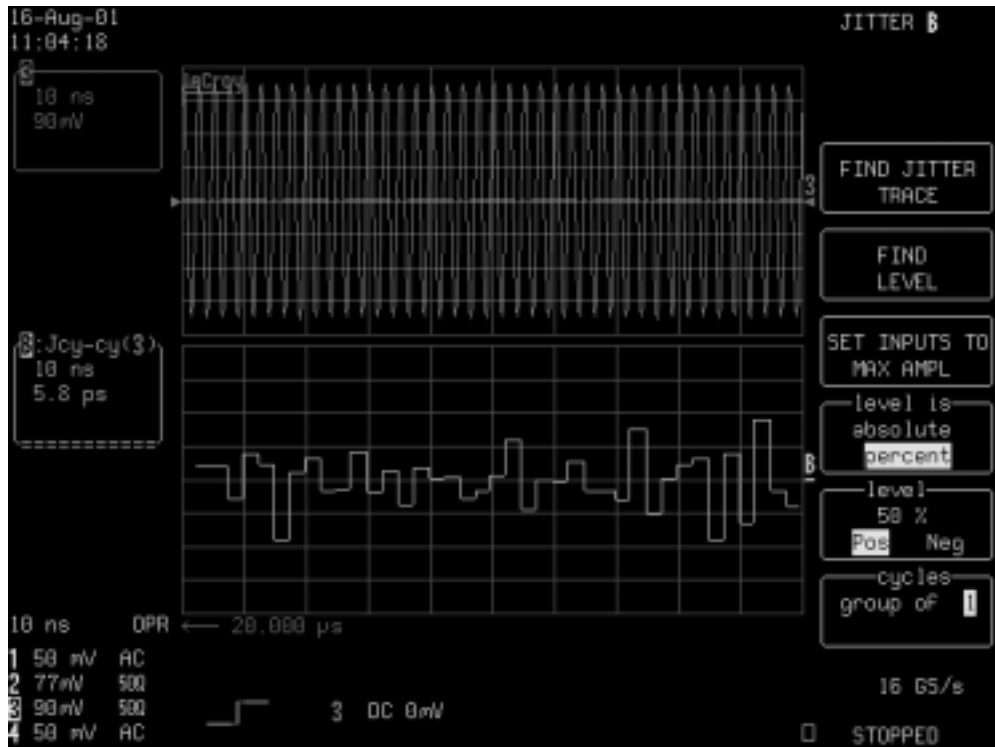

Cycle-Cycle JitterTrack on a clock signal

Cycle-Cycle: Data

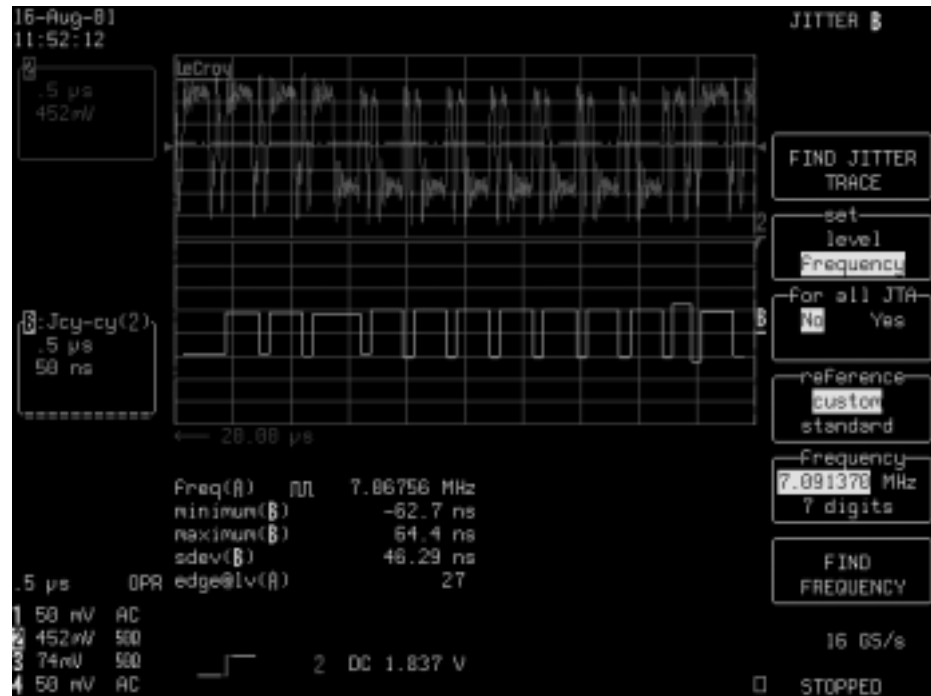

Cycle-to-Cycle JitterTrack on a data signal: Charts the differences in consecutive cycles across the waveform. When in Data Mode, JitterTrack normalizes cycle-to-cycle values to the clock frequency, which can be either automatically extracted from the data signal using Find Frequency or entered manually

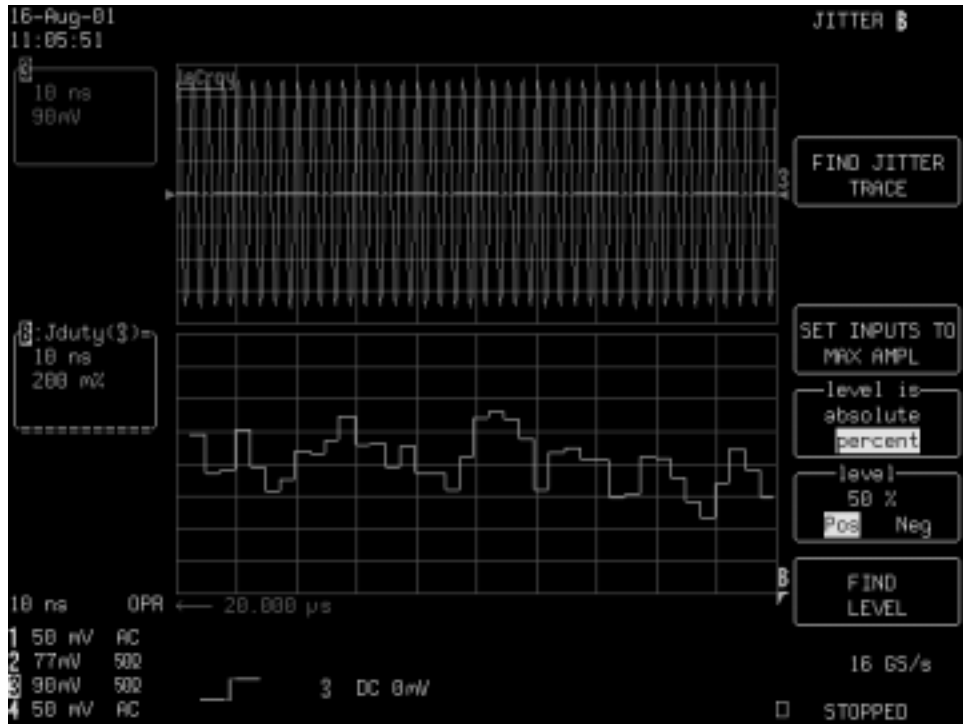
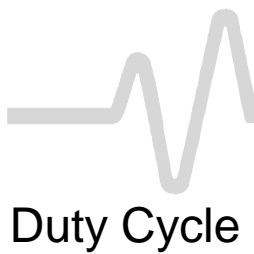

Duty Cycle JitterTrack: Charts consecutive duty cycles across the waveform. When the corresponding menu button is pressed, Find Jitter Trace automatically scales the JitterTrack to display the highest and lowest values that mark the limits of the range.

Time Interval Error: Clock

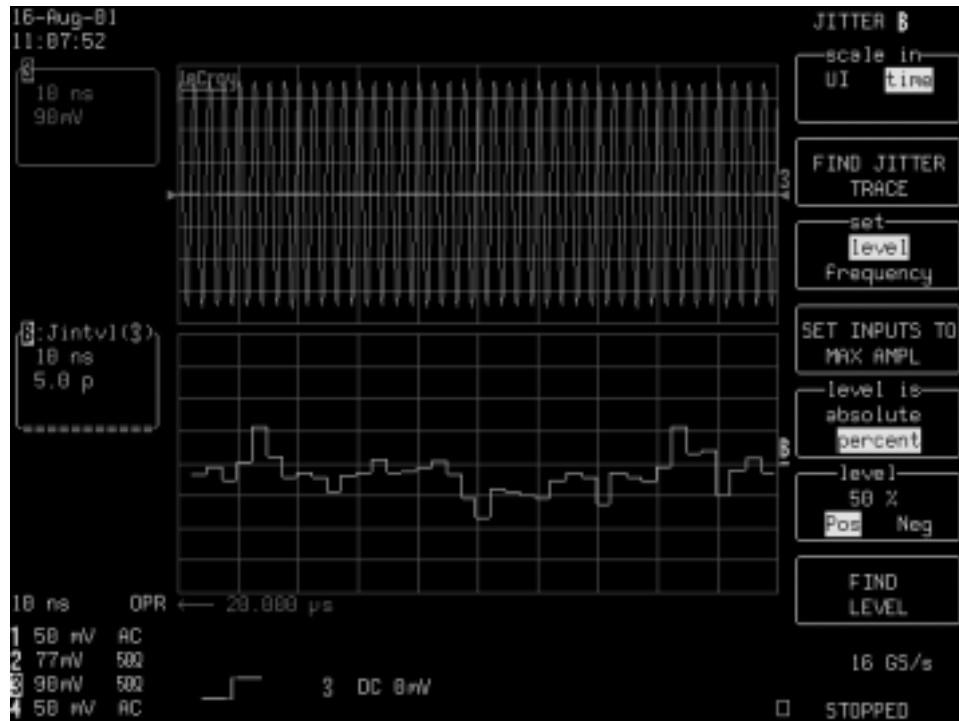

Time Interval Error JitterTrack on a clock signal: Charts the timing errors across the waveform by comparing the signal with a user-selected reference, in this case an ideal clock frequency of 400 MHz. The level can be set automatically using Find Level or entered manually.

Time Interval Error: Data

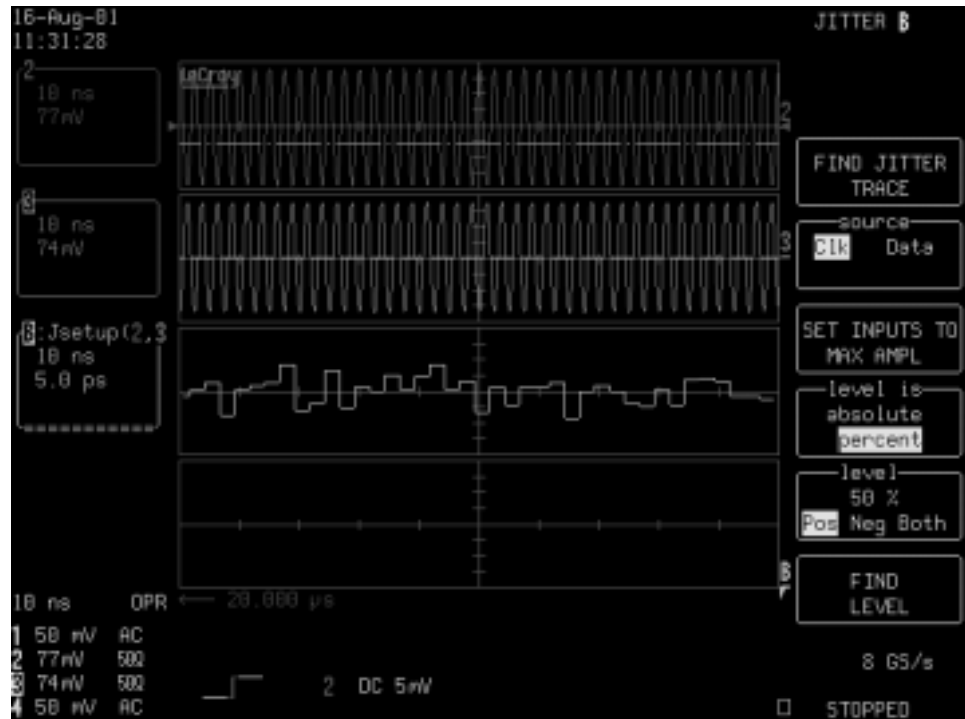

Interval Error JitterTrack on a data signal: Charts the timing errors across the waveform by comparing the signal with a user-selected reference. When in Data mode, Interval Error normalizes the interval error values to the clock frequency to increase timing resolution

Period: Clock

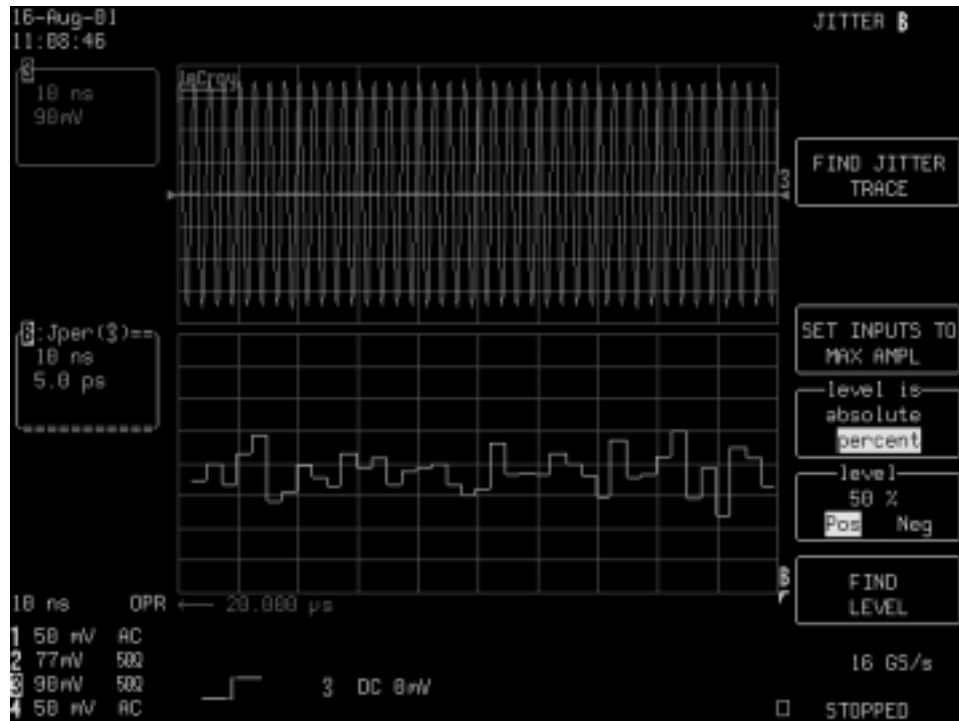

Period JitterTrack on a clock signal: Charts the periods across the waveform. The level can be set automatically using Find Level or entered manually.

Period: Data

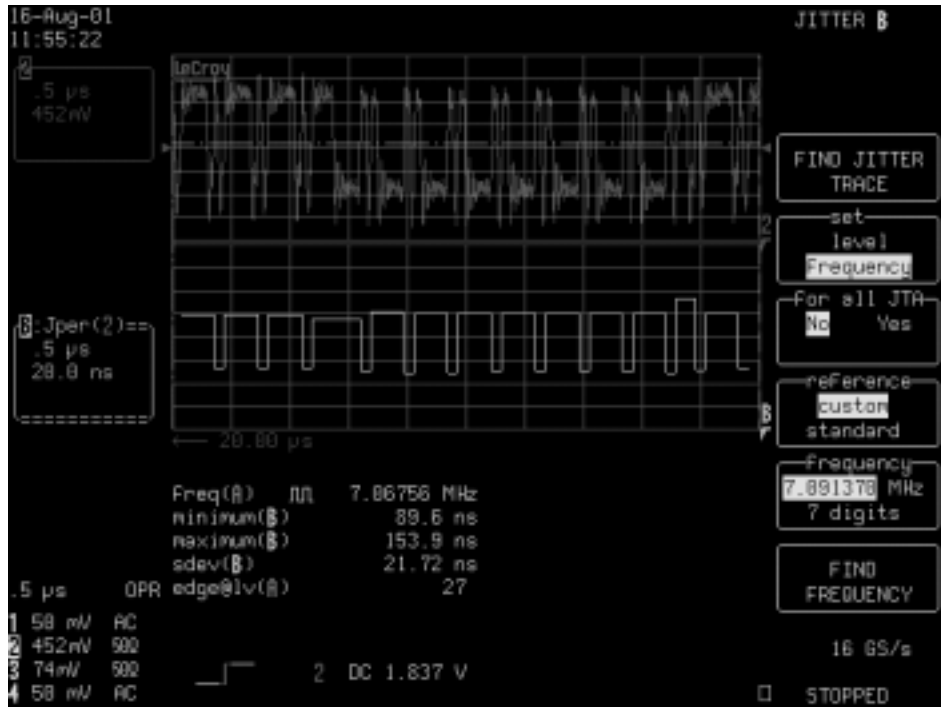

Period JitterTrack on a data signal: Charts the periods across the waveform. When in Data mode, JitterTrack normalizes cycle-cycle values to the clock frequency, which can be either automatically extracted from the data signal using Find Frequency or entered manually.

Half Period

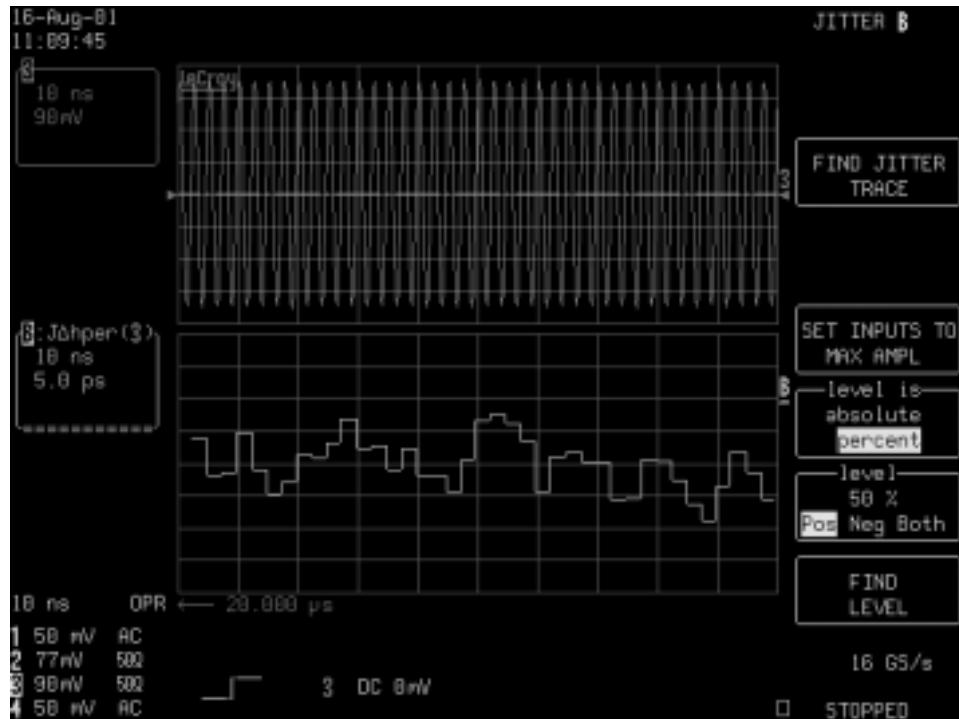

Half Period JitterTrack: Charts the relation of a half period to the full period that it is a part of, always measuring the half period value of the leftmost half period in the full period. If Level is set to Pos, it measures every other half period beginning with the positive slope of the period. If Level is set to Neg, it measures every other half period beginning with the negative slope of the period. If Level is set to Both, it measures every half period.

Width

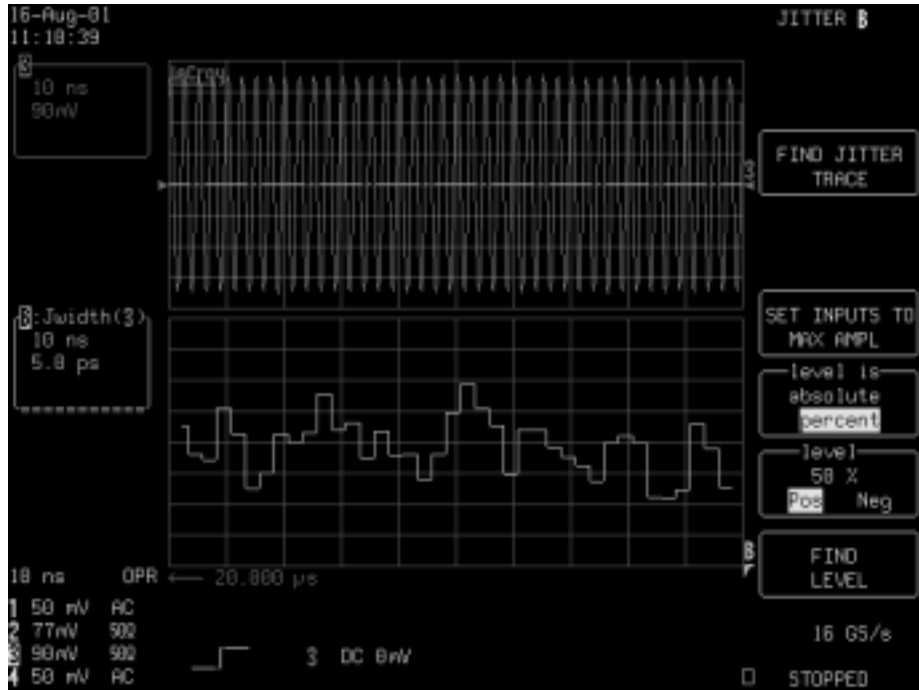

Width JitterTrack: Charts the pulse widths across the waveform. Note the number of sample points used by the measurement indicated in the field beneath the grid. When the corresponding menu button is pressed, Find Jitter Trace automatically scales the JitterTrack to display the highest and lowest values that mark the limits of the range.

Frequency: Clock

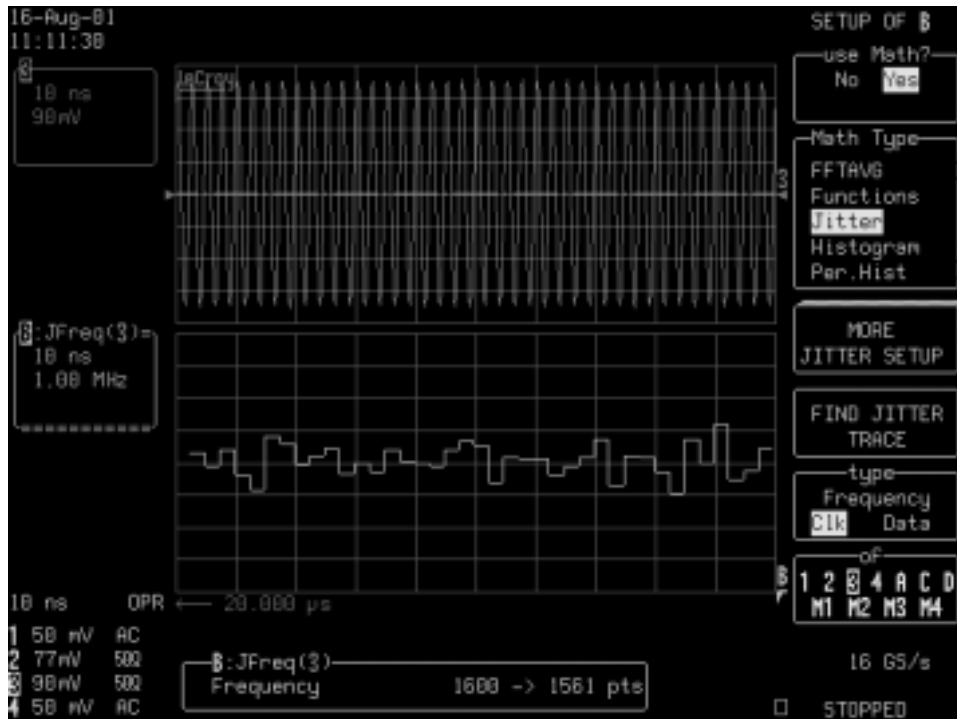

Frequency JitterTrack on a clock signal: Charts frequency across the waveform. The level can be set automatically using Find Level or entered manually.

Frequency: Data

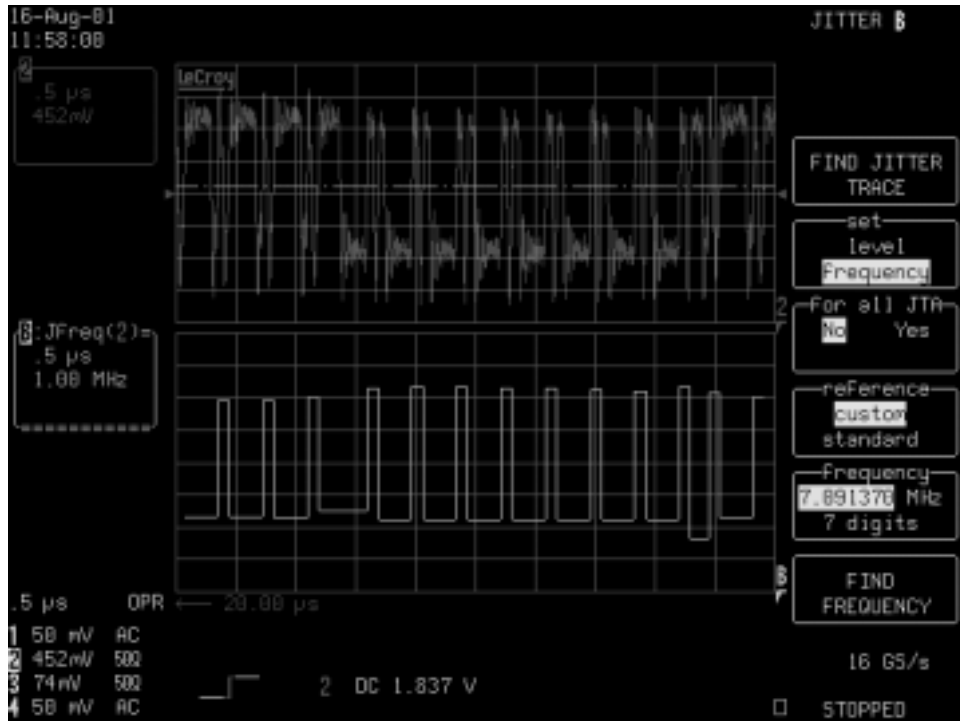

Frequency JitterTrack on a data signal: Charts frequency across the waveform. When in Data mode, JitterTrack normalizes data frequency values to the clock frequency, which can be either automatically extracted from the data signal using Find Frequency or entered manually.

Setup

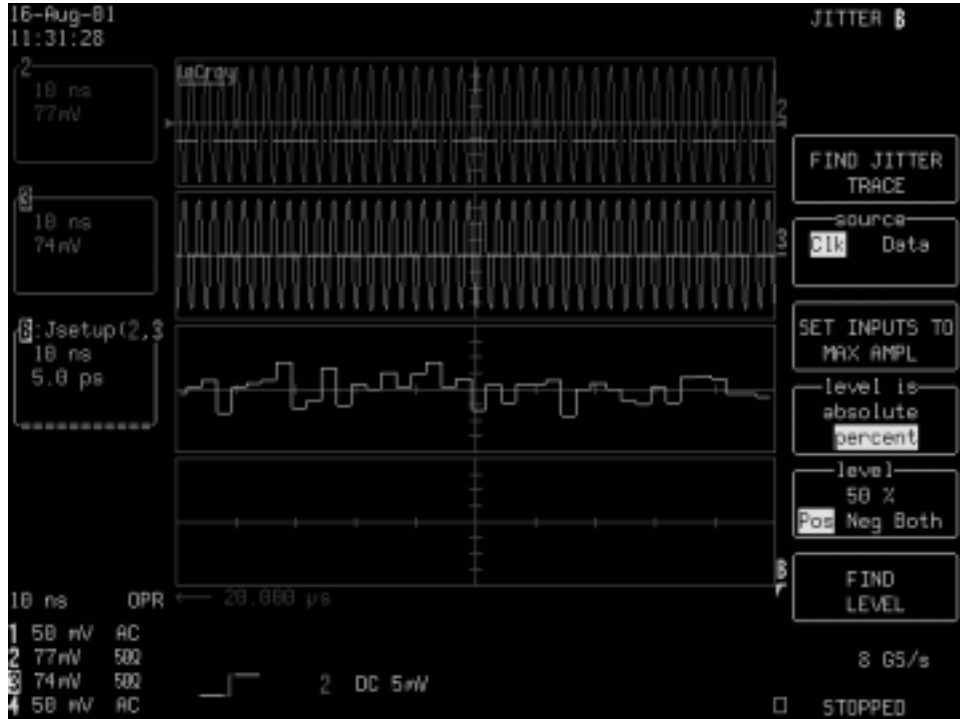

Setup: Charts absolute value of time between data edge nearest next clock edge.

Hold

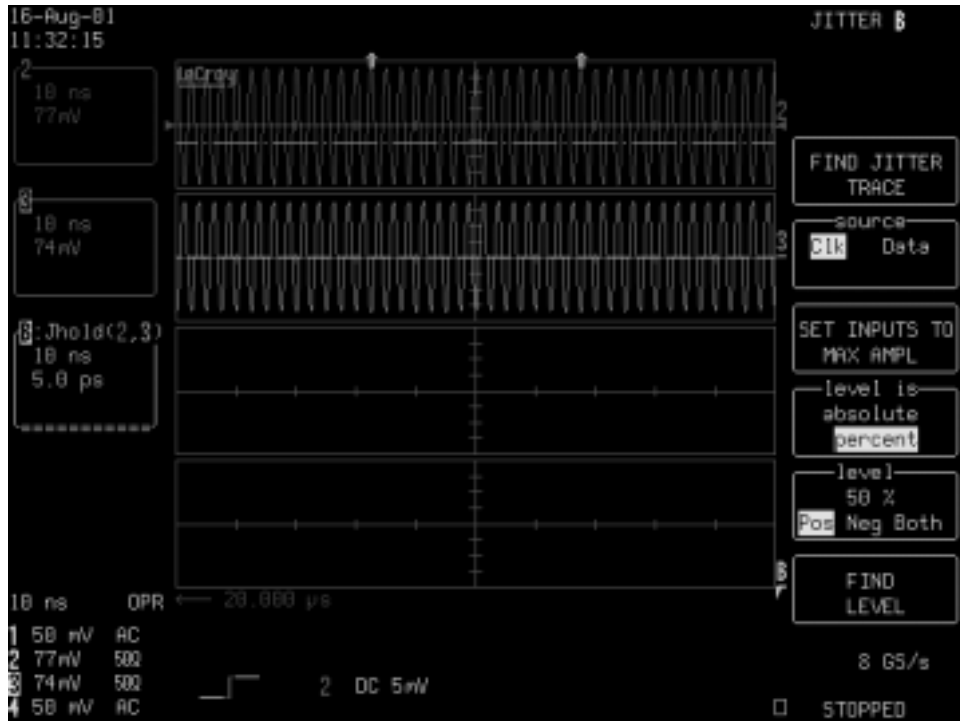

Hold: Charts absolute value of time between data edge to nearest previous clock edge.

Skew

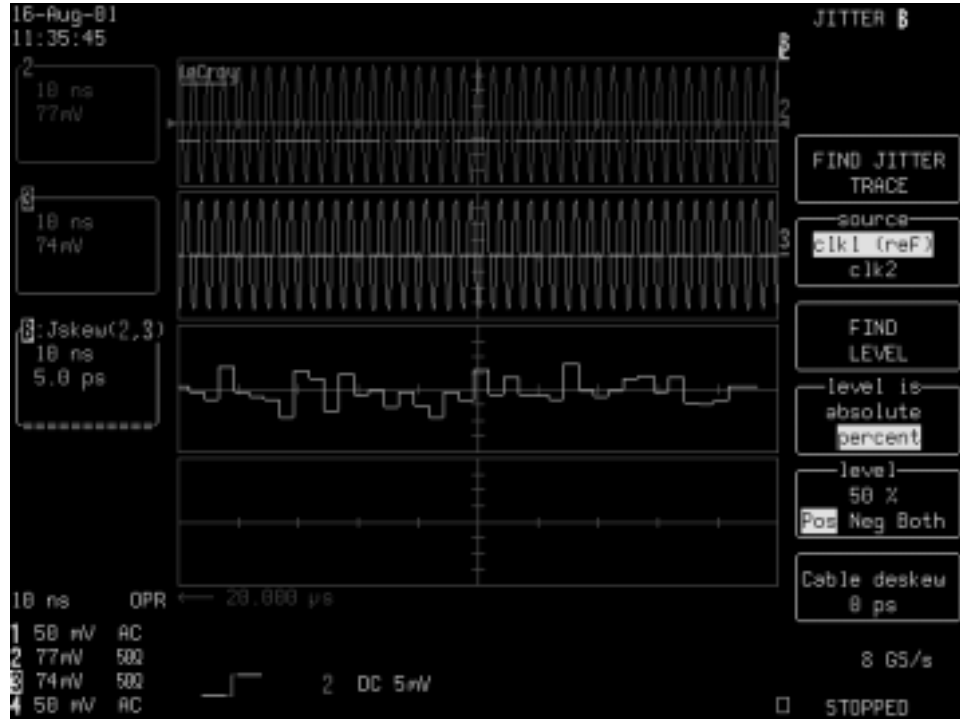

Skew: Charts skew between two signals.

§ § §



BLANK PAGE

Advanced Histogram Setup and Configuration

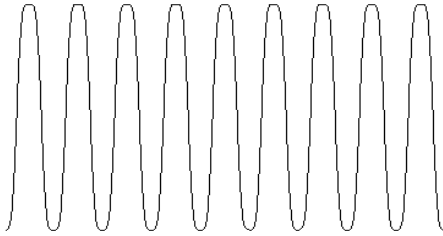

Display the waveform to be analyzed.

Apply a timing parameter — period at level (p@lv), for example.

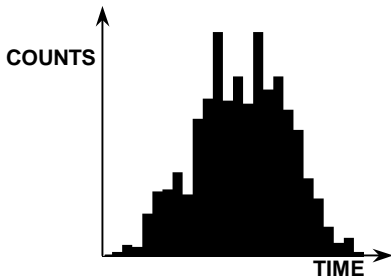
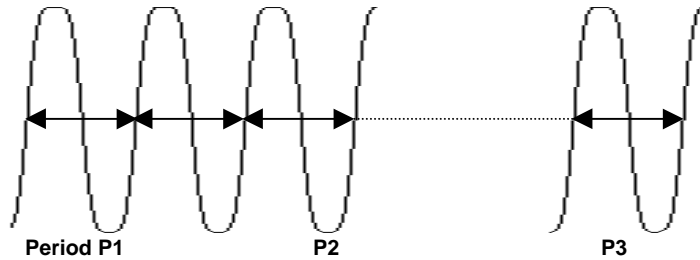

Create a histogram of the parameter.

Apply another parameter — range, for example — to the histogram itself.

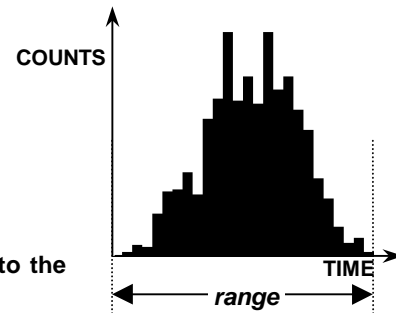



Histograms graph the statistical distribution of a timing parameter's set of values. The histogram bar chart is divided into intervals, or bins. The height of each bar in the chart is proportional to the number of data points contained in each of its bins: the higher the bar, the more points there are in those bins and in the area of the waveform they represent.

A histogram can identify the type of statistical distribution in the waveform, helping to establish whether or not signal behavior is as expected. Distribution tails or extreme values related to noise, or other infrequent, non-repetitive sources, may also be noted. Revealed, too, are multiple frequencies or amplitudes that help separate out jitter and noise.

Setting Up for Histograms

Quickly displaying a histogram of a timing parameter was already discussed in Chapter 1 when the operation of the JITTER ANALYSIS TOOLBAR was described. However, there are times when you may want to trade off the ease of use of the **HISTOGRAM** button for more flexibility. This section is intended to show you how to set up a histogram, or multiple histograms, on any of the Math Traces.

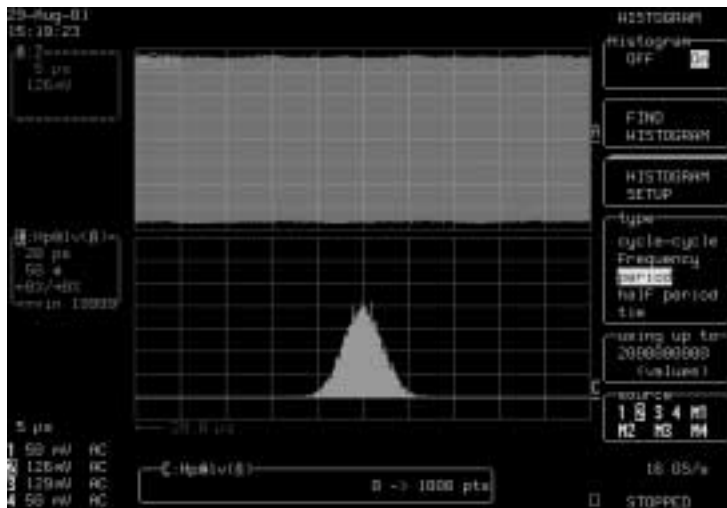

The waveform displayed, a timing parameter is chosen for histogramming.

Statistical Tools: Making Histograms

The example waveform has 20,000 cycles, with 20,000 period@level (p@lv) parameter values for each histogram and each sweep. A histogram based on p@lv can now be created. But before this can be done, the waveform trace must be defined as a histogram.

1. Press **MATH TOOLS** on the Jitter and Timing Analyzer front panel to display the **Zoom + Math** menus. They allow redefinition of any of the four traces A, B, C and D. Access their **Setup** menus. (Alternately, press the Trace **A**, **B**, **C**, or **D** button to access the **Setup** menu directly, and skip step 2 below).
2. Press the menu key for **Redefine C**, to configure the function — on Trace C for this example.
3. Select **Histogram** from the **Math Type** menu.
4. Press the menu key for **MORE HIST SETUP** , then press **PARAMETER SETUP** and select the p@lv parameter from the **Measure** menu.

In the case described above, the parameter was defined as being “on-line” 1. Other lines could be chosen, but make sure that the correct line is chosen in the **Histogram** menu.

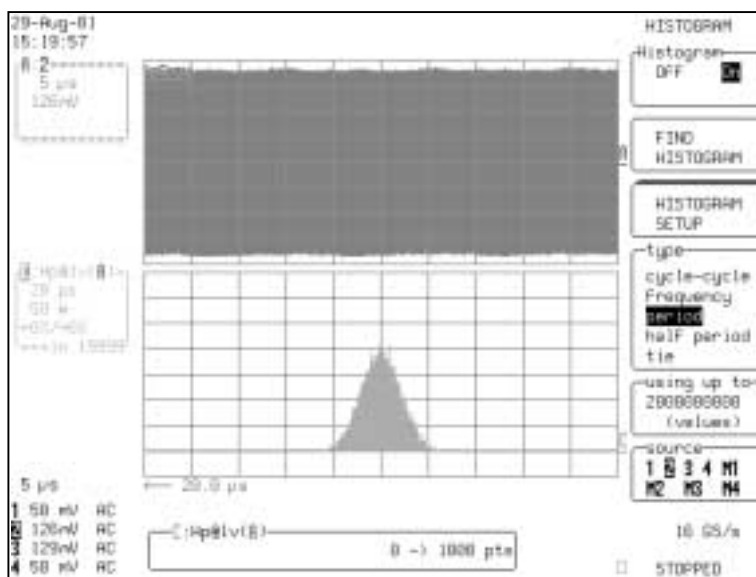



The waveform has been defined as a histogram; p@lv is on custom line 1. Note information field beneath grid indicating that Trace C is a histogram of p@lv for the waveform on Trace A [H p@lv(A)].

- For more timing parameters, press the button or turn the knob to obtain the parameter in the **Histogram custom line** menu. Each time a waveform parameter value is calculated, it is placed in a histogram bin. The maximum number of such values is selected from the **Using Up To** menu shown below. From 20 to 2,000,000,000 parameter value calculations can be histogrammed.

Displaying a Histogram

To display the histogram bar chart:

- Make sure that the measurement level is set by pressing **MORE HIST SETUP**, **PARAMETER SETUP**, then **MORE P@LV SETUP** and adjusting the level.
- Make sure the Trace is ON by pushing the Trace button **C** and turning the Trace ON.
- Select the **Find Center and Width** menu to allow calculation of the optimal center and bin-width values, based on the most recently calculated parameter values. The number of parameter calculations is chosen with the **Using Up To** menu (20000 values if greater than this number). Typical result is shown below.

Setting Histogram Range



```
Hp@1v(A)=
20 ps
50 #
<-0%/>0%
===in 19999
```

9. Add grids to the display, if desired, by pressing Display on the front panel and setting the grids in the **Grids** menu.

Histograms are set up to capture parameter values falling within a specified range. As the instrument captures the values in this range, the histogram's bin counts increase. Values that do not fall within the range are not used.

A histogram's range is represented by the horizontal width of the entire histogram baseline.

Statistical information from the histogram is reported in the displayed trace field (like the one shown at left). The information includes:

1. The current horizontal-per-division setting for the histogram (20 ps in the example). The unit of expression is in accordance with the type of parameter from which the histogram has been made.
2. The vertical scale in number (#) of bin counts per division (here, 50).
3. The number of parameter values that fall inside the range (inside 19,999), the number of cycles in the waveform.
4. The percentage of parameter values that fall below, and above, the range (here, <-0%/>0%).

Histograms can be positioned and zoomed like any other waveform. If the trace on which the histogram is made is **not** a zoom, all bins having events will be displayed.

5. Press **MATH TOOLS** to reset the trace and display all histogram events.
6. Select **MORE HIST SETUP** to specify additional histogram settings. **Histogram** menus (described on next page) will appear.

Setting Binning and Scale

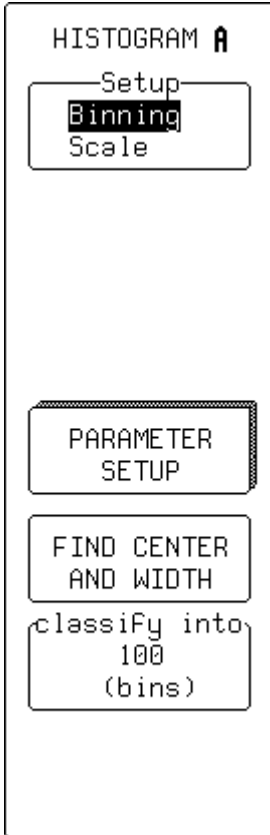

Setup

Allows adjustment of either the histogram binning or scale settings.

When **Binning** is selected, the **Classify Into** menu appears (see below). The number of bins can be set within a range of 20 to 2000 in a 1-2-5 sequence, by pressing the corresponding menu button or turning the associated knob. (For **Scale** options see next page.)

PARAMETER SETUP

To access the **Change Param** menu group for selection of new, or modification of current, timing parameters. Or for selection of histogram parameters (see page 4-10).

FIND CENTER AND WIDTH

For calculating optimal center- and bin-width values for the histogram.

-classify into-

For choosing the number of bins into which the parameter events are to be classified, or distributed.

Statistical Tools: Making Histograms

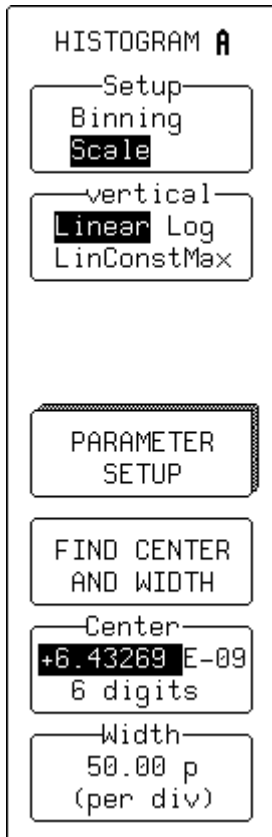

-SETUP-

Allows adjustment of either the histogram binning or scale settings. When **Scale** is selected, the menus shown here appear.

-vertical-

For setting the vertical scale:

Linear sets a linear vertical scale. The baseline of the histogram designates bin value of "0." As the bin counts increase beyond those that can be displayed on screen, scale is automatically increased in a 1-2-5 sequence.

Log sets logarithmic vertical scale. A value of "0" cannot be specified logarithmically, so no baseline is provided.

LinConstMax sets vertical scaling to a linear value that uses close to full vertical display capability of instrument. Height of histogram will remain nearly constant.

The instrument automatically increases the vertical scale setting as required, ensuring that the highest histogram bar does not exceed the vertical screen display limit.

PARAMETER SETUP

To access the "Change Param" menu group for selection of new, or modification of current, timing parameters. Or for selection of histogram parameters (see next page).

FIND CENTER AND WIDTH

For calculating optimal **center-** and **bin-width** values for the histogram (see menus below).

-Center-

To set the histogram center value.

-Width-



Jitter and Timing Analyzer

To set the histogram width value per division. The width per division multiplied by the number of horizontal display divisions (ten) determines the range of parameter values centered on the number in the “Center” menu, used to create the histogram.

Applying Histogram Parameters

With the histogram made and its settings adjusted to provide desired information, additional parameter values (Histogram Parameters) can be applied to measure particular attributes of the histogram itself. For a complete list of Histogram Parameters, see Appendix B.

1. Select **MEASURE** and **Custom** measure mode to access **Change Param** menus (shown below).
2. Press **CHANGE PARAMETERS**.
3. Select the line on which to put the desired parameter in the **on-line** menu.
4. Select a parameter to measure in the **Measure** menu.
5. Select a trace to apply it to in the **Of** menu.

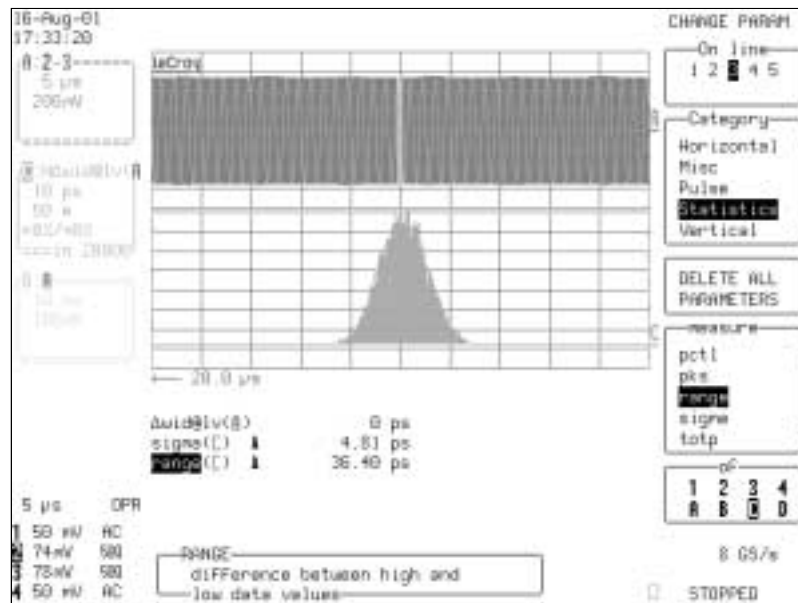



The **Change Param** menus enable selection of histogram parameters such as **sigma** and **range**, and their placement on a line.

As shown above, the histogram parameters **sigma** and **range** have been selected. **Sigma** determines the standard deviation of the histogram distribution, while **range** gives the horizontal difference between the high and low values.

The “**C**” beside the parameters listed under the grid indicates that the measurements are being made on the signal on **Trace C**, the histogram. Also indicated:

a **sigma (C)** value of **4.81 ps**

a **range (C)** value of **36.40 ps**

by the  icon: that these parameters are indeed applied to a trace defined as a histogram.

However, if these parameters were inadvertently set for a trace with no histogram, they would show “—”.

Zooms & Segments

The vertical and horizontal **position** and **zoom** control knobs can be used to expand and position the histogram, and for zooming-in on a particular feature. The resulting vertical and horizontal scale settings are shown in the **Displayed Trace Field** for the trace.

Histograms can also be displayed for traces that are zooms of segmented waveforms. When a segment from a zoomed trace is selected, the histogram for that segment will appear. Only the portion of the segment displayed, and which is between the parameter cursors, will be used in making the histogram. The **Displayed Trace Field** will show the number of events captured for the segment.

Note that to enable the zoom on a histogram, you must first press the **HISTOGRAM** button, or the math trace button on which the histogram was set up.

Clearing Events

Press **CLEAR SWEEPS** at any time to clear histogram events. All events in the 20000 parameter buffer are cleared at the same time.

However, the values in the **Center** and **Width** menus will **not** change, since they determine the range of the histogram and **cannot** be used to determine the parameter value range of a particular bin. If the histogram is repositioned using the horizontal **position** knob, the histogram's center will be moved from the center of the screen.

Using Cursors on Histograms

The measurement cursors are useful for determining the value and population of particular histogram bins.

1. Press **CURSORS** on the Jitter and Timing Analyzer to access the **Cursor** menu.
2. Choose the cursor required using the **Mode**, **Type** and **Show** menus. (See the *WavePro Operator's Manual* for more on cursors).

Shown below, the time cursor (downward pointing arrow) is positioned on a selected bin in **Trace C**, which corresponds to the cross-hair cursor on the waveform. The value of the bin and its population are also indicated, in the **Displayed Trace Field**.

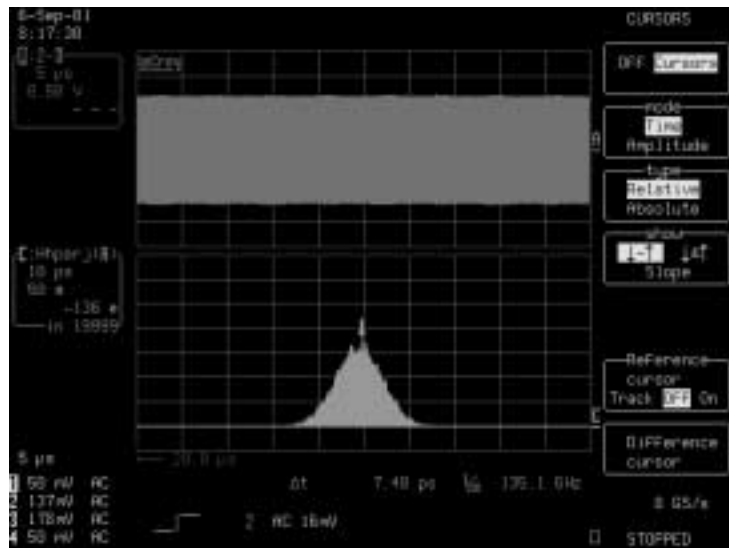

Cursors enable measurement of particular histogram bins.

§ § §

Advanced Timing Parameter Setup and Configuration

Quickly displaying timing parameters of a clock or data signal was already discussed in Chapter 1 when the operation of the JITTER VIEWS TOOLBAR was described. However, there are times when you may want to trade off the ease of use of the **MEASURE** button for more flexibility. This section is intended to provide you with the detail on how to set up timing parameters in the Custom listing in the Measure Mode menu.

Like the instrument's other parameters, Jitter & Timing Parameters perform waveform measurements automatically. They are applied and adjusted using dedicated on-screen menus and accessed by the following simple steps:

1. Press the **MEASURE** button in the **JITTER AND TIMING ANALYZER VIEWS TOOLBAR**.
2. Scroll through the **Mode** menu and choose **Custom**. In the **Statistics** menu below this, **ON** can be selected to display each parameter's **average, low, high, and sigma** values.
3. Press the menu button for **Change Parameters**. (See page 5-5.)
4. From the **Category** menu, select **JTA**. The timing parameters will then appear as a group in the Measure menu.

Note:

Each Jitter and Timing Analysis parameter operates on a level of the acquired waveform that can be selected either in volts or as a percentage of signal amplitude.

Each parameter calculation is performed over all cycles or edges present in the input signal, without limitation. The acquired set can then be analyzed using Histograms or Trends (see Chapter 4 and 8).

Advanced interpolation filtering is applied to the signal edges in the vicinity of the measurement points to optimize measurement accuracy, repeatability and speed.

5. Choose the desired parameter, which will be highlighted both on the **Measure** menu and beneath the grid. Up to five parameters can be selected for display, each shown on its



Jitter and Timing Analyzer

own line below the grid. Other kinds of parameters can also be selected from these menus, such as histogram parameters from the **Statistics** category (see next chapter).

Note:

If custom parameter listings are defined in **Custom** mode, they will be overwritten if you switch to **Jitter Data**, **Jitter Stat**, or **Signal Integ** modes.

Applying Timing Parameters

Which Parameter?

This table lists the Jitter & Timing Parameters (second column from left) and offers hints on the tasks they can perform. Additional analysis and processing of the waveform can be carried out by activating **Statistics** and using histogram parameters (as described on the previous page). Finally, one of the variants of **JitterTrack** (see Chapter 3) might serve as an alternative for the same task.

To...	Use Timing Parameter:	For Further Processing, Use	Or <i>JitterTrack</i> ...
Measure accuracy of clock, period or frequency,	p@lv freq@lv	Statistics ON or use Histogram	Period Jitter Frequency Jitter
Measure accuracy of half clock period compared to whole period	hperj@lv	Statistics ON or use Histogram	Half Period Jitter
Measure pulse width accuracy,	wid@lv	Statistics ON or use Histogram.	Width Jitter
Measure adjacent cycle deviation,	Delta p@lv	Statistics ON or use Histogram.	Cycle-Cycle Jitter
Count number of edges in a waveform,	edge@lv	—	—
Measure duty cycle,	duty@lv	Statistics ON or use Histogram.	Duty Cycle Jitter
Measure duty cycle error	Delta wid@lv	Statistics ON or use Histogram.	—
Measure time interval error...	tie@lv	Statistics On or use Histogram.	TIE Jitter
Measure n-cycle	Delta p@lv	Statistics ON or use Histogram	Cycle-Cycle Jitter
Measure skew	skew	Statistics ON or use Histogram	Skew

Jitter and Timing Analyzer



Measure absolute value of time between data edge to nearest previous clock edge	hold	Statistics ON or use Histogram	Hold Jitter
Measure absolute value of time between data edge to nearest next clock edge	setup	Statistics ON or use Histogram	Setup Jitter

The menus shown on this and the following page are displayed when, for example, period-at-level on **Clock** is selected as the timing parameter. These menus and their descriptions are representative of all the timing parameters except **tie@lv** (see page 5–12).

p@lv — period at level

Calculates the period of each cycle in an acquired waveform.

```
CHANGE PARAM
-----
-On line-
 1 2 3 4 5
-----
-Category-
DISK-Local
DISK-PRML
JTA
OPTICAL-Data
Cyclic
-----
MORE p@lv
  SETUP
-----
-measure-
edge@lv
Freq@lv
p@lv
tie@lv
wid@lv
-----
-source-
1 2 3 4 A B C
 Clk Data
```

-On line-

Selects for modification as many as five different parameters, each placed on its own line: **1**, **2**, **3**, **4** or **5**.

-Category-

Specifies the category of parameter. When **JTA** is selected, the **Measure** menu (below) will feature the jitter & timing parameters.

MORE p@lv SETUP

Accesses **Setup p@lv** menus (next page).

-measure-

For choosing the parameter to be measured on the selected line.

-source-

Selects the channel or trace on which the parameter will be measured and whether **Clock** or **Data** mode will be used. The associated menu knob highlights the channel or trace, while the corresponding button changes the **Clk / Data** selection.

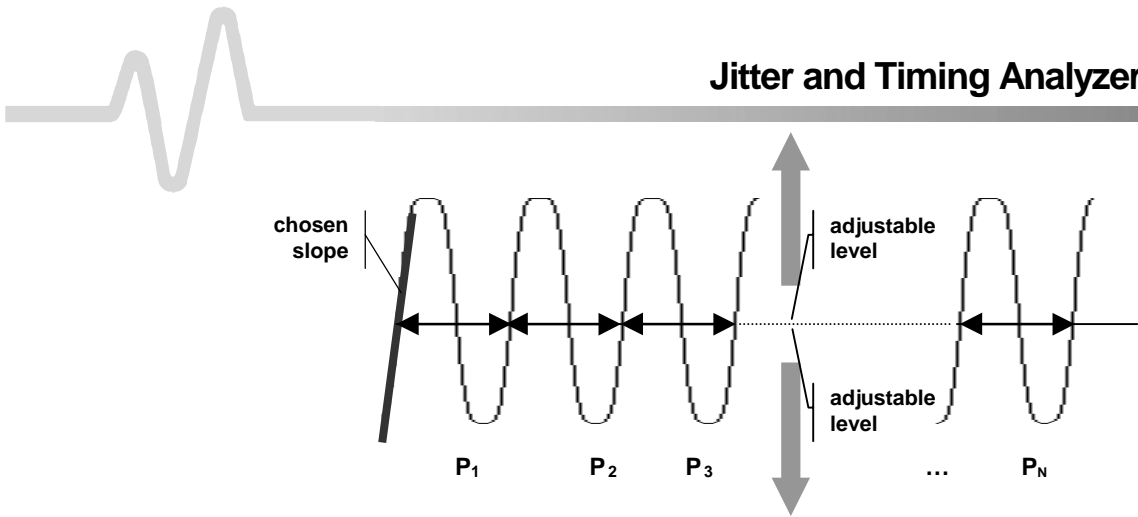

p@lv: measures the period of all cycles in the waveform; level and slope are specified by the user.

SETUP p@lv (Level)

SETUP p@lv

SET INPUT TO
MAX AMPL

level is
 absolute
 percent

level
 0 μ V
 Pos Neg

FIND
LEVEL

A menu group like the one shown here appears when **Clock** mode and **MORE... SETUP** is selected (see previous page), allowing comprehensive level configuration. But when **Data** mode is selected, both level and frequency are set up (see page 5–9). The exception is **tie@lv** (page 5–8), which offers both level and frequency in either **Clock** or **Data** mode.)

SET INPUT TO MAX AMPL

If the source is a channel or a trace displaying a zoom of a channel, pressing this button is equivalent to selecting **Var Gain** and pressing **FIND**, for the source channel. This maximizes **SNR**, which can improve measured jitter.

-level is-

Determines whether the levels should be set in absolute — in volts — or as a percentage of signal amplitude.

-level-

For selecting the voltage or amplitude-percentage setting of the level on the waveform at which the timing is to be measured. Also selects whether the measurement should be made on a **Pos**(itive or rising edge) or a **Neg**(ative or falling edge).

FIND LEVEL

Automatically finds and sets the threshold to the appropriate level.

Applying Timing Parameters

freq@lv (frequency at level) Returns the frequency of each pulse in acquired waveformMenus and

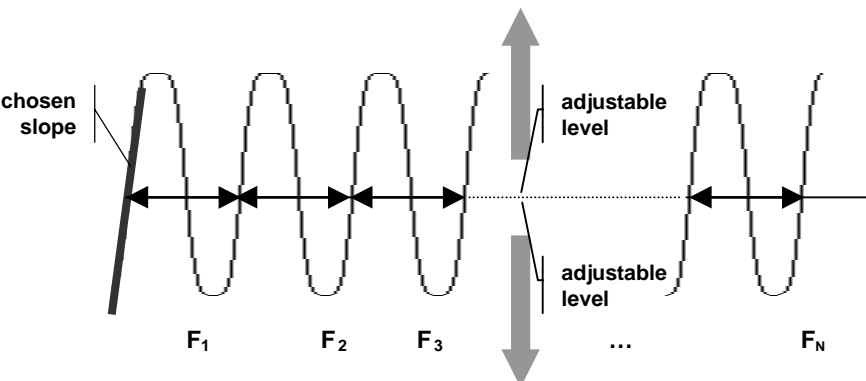

setup for **freq@lv** are the same as for **p@lv**.

freq@lv: measures the frequency of pulses in the waveform; level and slope are specified by the user.

wid@lv (width at level)

Returns **width, positive or negative**, of each pulse in acquired waveform. Menus and setup are same as for **p@lv**.

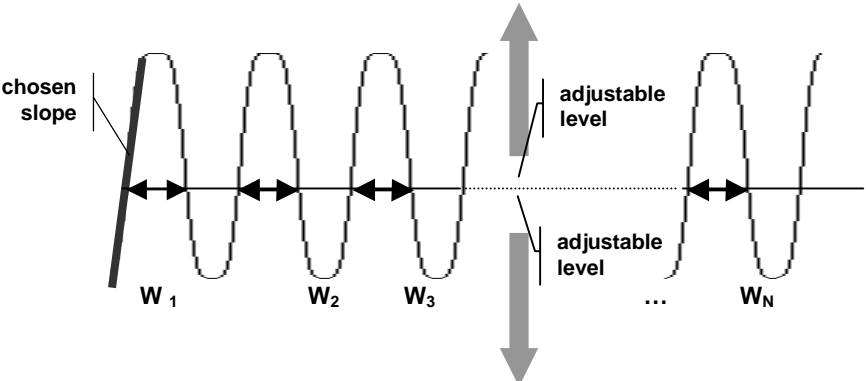

wid@lv: measures the width of all pulses in the waveform; level and slope are specified by the user.

Delta p@lv (delta period at level) Calculates adjacent cycle deviation (cycle-cycle jitter) of each cycle in acquired waveform. Menus and setup are same as for p@lv.

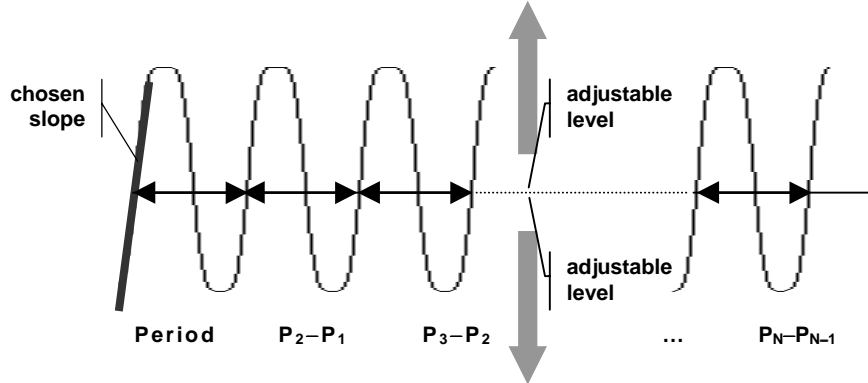

Delta p@lv: measures the difference between consecutive cycles in the waveform; level and slope are specified by the user.

edge@lv (edge at level)

Counts number of edges, positive or negative, in source trace. Menus and setup are same as for p@lv.

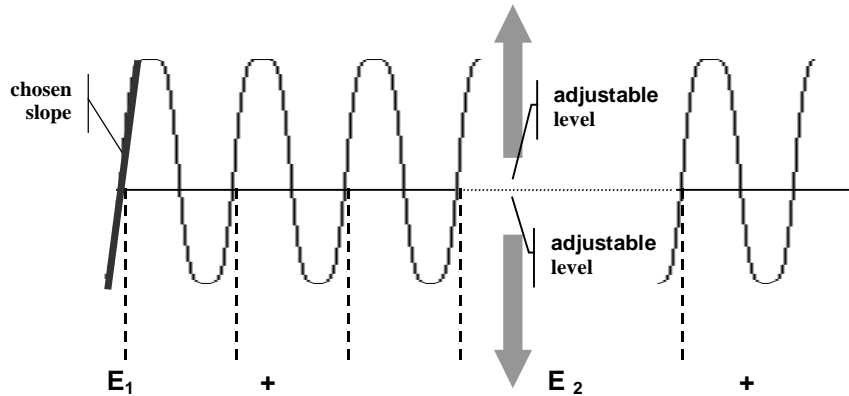

hperj@lv (Half Period@Level)

SETUP OF B

use Math? No **Yes**

Math Type
FFTAvg
Functions
Jitter
Histogram
Per.Hist

MORE
JITTER SETUP

FIND JITTER
TRACE

type
Intvl.Error
Clk Data

of
1 2 3 4 **A** C D
M1 M2 M3 M4

Calculates the relation of a half period to the full period. That it is a part of, always measuring the half period value of the left most half period in the full period. If **level** is set to Pos, it measures every other half period beginning with the positive slope of the beginning with the negative slope of the period. If **level** is set to Both, it measures every half period.

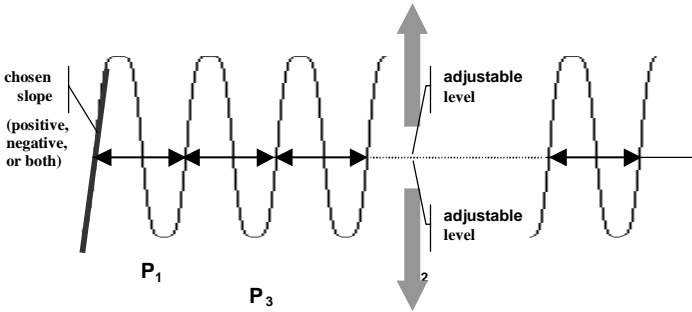

duty@lv (duty cycle at level) Calculates the duty cycle of each period in the source trace. The menus and setup for this parameter are the same as for those of **p@lv**.

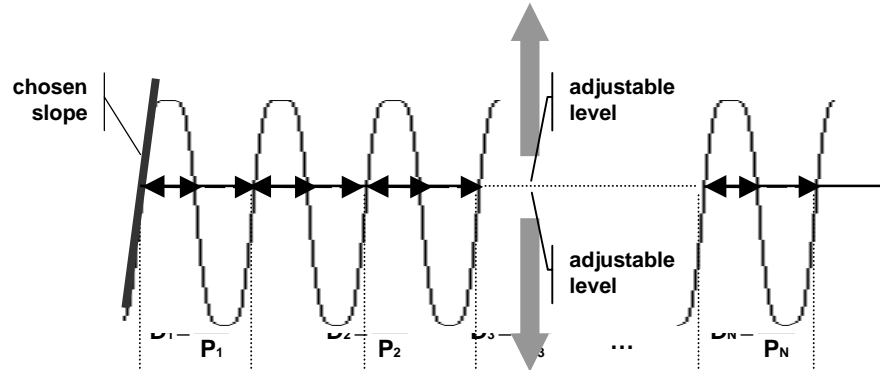

duty@lv: measures the duty cycle of each period in the waveform (pulse width over period); level and slope are specified by the user.

skew@lv (skew at level)

Calculates the skew time between **Clock 1** and *Clock 2*. You specify the level and slope for each clock edge.

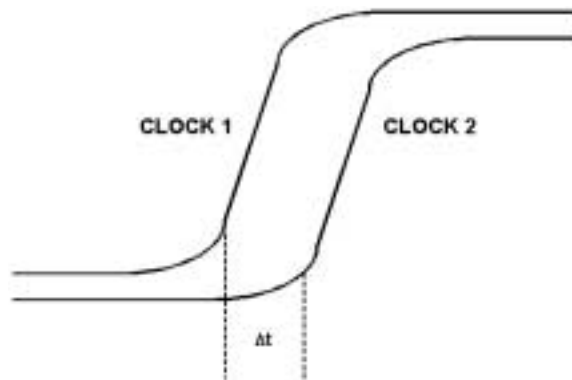

skew@lv: measures the skew in the waveform; level and slope are specified by the user.

Applying Timing Parameters

setup

Calculates the setup time from the delay edge to the clock edge. You specify the level and slope for each edge.

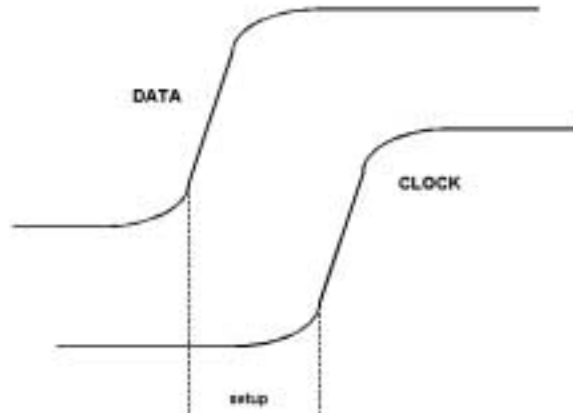

setup@lv: measures setup in the waveform; level and slope are specified by the user.

hold

Calculates the hold time from the clock edge to the data edge. You specify the level and slope for each edge.

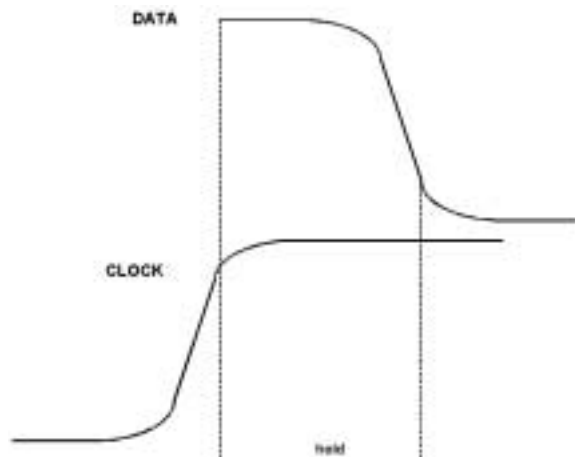

hold@lv: measures hold in the waveform; level and slope are specified by the user.

Delta wid@lv (duty cycle error)

Calculates the percent of the period for which the data is above or below a level. You specify the level and polarity.

tie@lv (time interval error at level)

Calculates the time interval error in the signal, compared with an "ideal" reference position defined by the user.

```
CHANGE PARAM
  On line
  1 2 3 4 5
  Category
  DISK-Local
  DISK-PRML
  JTA
  OPTICAL-Data
  Cyclic
  MORE tie@lv
  SETUP
  measure
  edge@lv
  Freq@lv
  p@lv
  tie@lv
  wid@lv
  source
  1 2 3 4 A B C
  Clk Data
```

-On line-

To select, for modification, as many as five different parameters, each placed on a line: **1**, **2**, **3**, **4** or **5**.

-Category-

To specify the category of parameter. When **JTA** is selected, the **Measure** menu (below) will feature the jitter & timing parameters.

MORE tie@lv SETUP

Primary menu that calls up the secondary **Setup tie@lv** menus (next page).

-measure-

To choose the new parameter to be measured on the selected line.

-source-

Selects the channel or trace on which the parameter will be measured. And whether **Clock** or **Data** mode will be used. The associated menu knob highlights the channel or trace, while the corresponding button changes the **Clk / Data** selection.

Applying Timing Parameters

SETUP tie@lv (frequency)

These menus appear when “frequency” is chosen from “set” below. For an example of those menus displayed when level is chosen, see page 5-4.

```
SETUP tie@lv
scale in
  UI  time
SET INPUT TO
MAX AMPL
  set
  level
  Frequency
level is
  absolute
  percent
level
  0 μV
  Pos  Neg
FIND
LEVEL
```

-scale in-

Expresses the attribute in either unit intervals (**UI**) or **time** (in seconds).

-set-

Enables the choice of either **level** or **frequency** (see next page) setup. When **frequency** is chosen, the menus below reflect this.

-For all JTA-

Global effect: when **YES**, the frequency will apply to all jitter & timing parameters for which data is available.

-reference-

Enables the choice for the reference clock of either a **custom**, user-defined, frequency, or selection from a list of standard, pre-defined, frequencies. The frequency is adjusted using the menu immediately below.

-frequency-

When custom has been chosen from the reference menu, a particular user-defined frequency can be selected. The corresponding button for this menu highlights either the mantissa, or the frequency decade or number of digits, while the associated knob changes the highlighted value. When standard has been chosen, selection from a number of pre-defined frequencies can be made for the reference clock, using the menu button.

FIND FREQUENCY

Appears when **frequency** is selected from the **Set** menu (above). Automatically detects frequency and sets the bit rate.

Jitter and Timing Analyzer

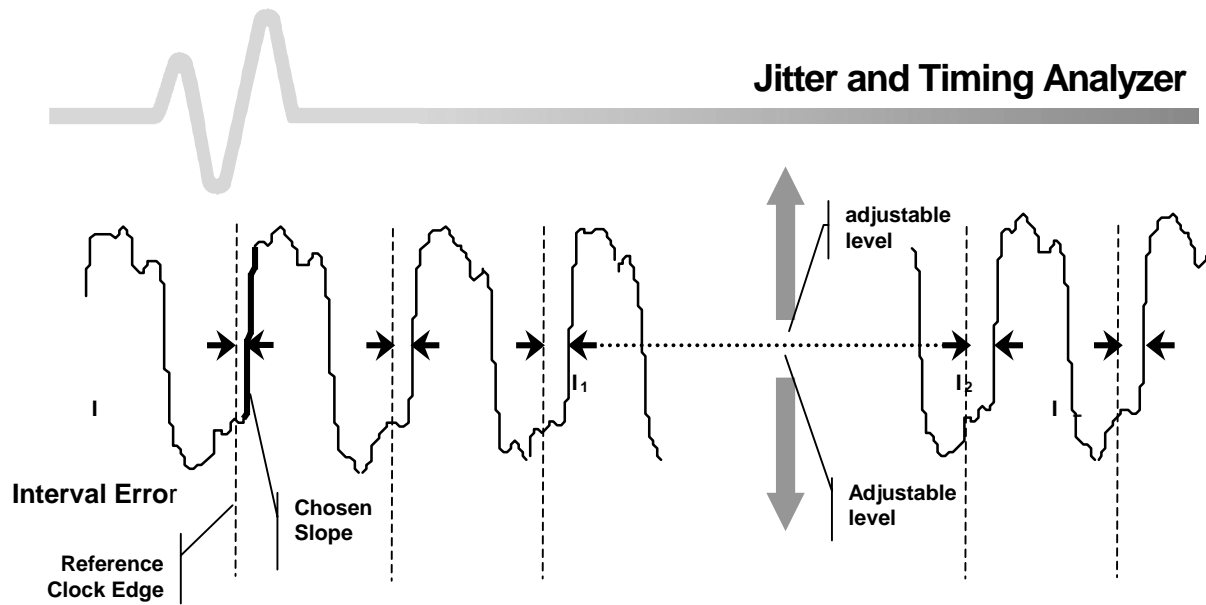

tie@lv: measures the time-interval error in each waveform pulse against a specified reference clock; level and slope are also specified by the user.

§ § §

How to Use JitterFFT

- Display the JitterTrack to be analyzed
- Apply a JitterFFT to the JitterTrack, and zoom/position the JitterFFT is to read frequency data.

The JitterFFT analysis tool provides a special (frequency) view that consists of the timing domain JitterTrack into a frequency domain spectrum similar to that of an RF spectrum analyzer display. However, unlike a spectrum analyzer, which has controls for span and resolution bandwidth, you determine the FFT span using the scope's sampling rate. This view often reveals critical insights into sources of jitter. The display's vertical axis displays amplitude and the horizontal axis displays frequency.

There are two methods to create a JitterFFT on the Jitter and Timing Analyzer. The easiest method is to use the Jitter Views toolbar Analysis button to access the Analysis menu. When this method is used, certain defaults are set, and the JitterFFT will be displayed as Trace C. This method is explained below:

1. Acquire a clock or data signal, and display the relevant JitterTrack for that signal.
2. Press the Analysis button in the Jitter Views Toolbar and select JitterFFT from the menu.
3. Use the horizontal position and Zoom front panel knobs in the Analysis Controls section to position and expand the JitterFFT to see the detail desired.

A JitterFFT can also be set up on any math trace by following the instruction below:

1. Press Math Tools
2. Press the menu button "REDEFINE D", for example. This will place the JitterFFT on trace D.
3. Select **Yes** from "Use Math" menu to enable math functions, including FFT.
4. Choose **FFT** from the "Math Type" menu.
5. Make a selection for "FFT Result".

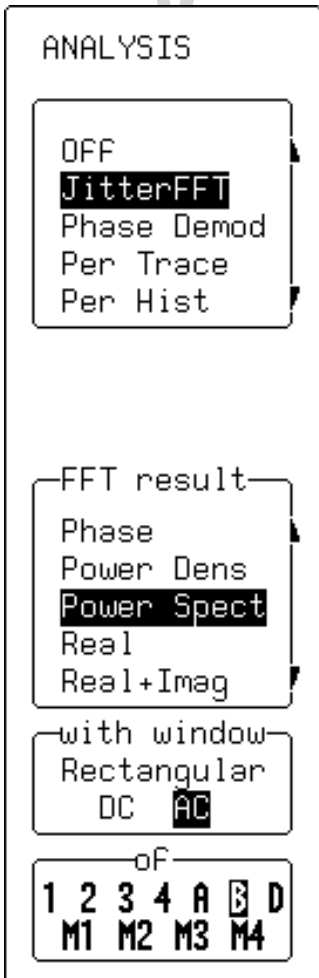

Power Spectrum is the signal power, or magnitude represented on a logarithmic vertical scale: 0 dBm corresponds to the voltage (0.316 V peak), which is equivalent to 1 mW into 50 ohms. Power Spectrum is suitable for characterizing spectra that contain isolated peaks (dBm).

Phase is measured with respect to a cosine whose maximum occurs at the left-hand edge of the screen, at which point it has 0°. Similarly, a positive-going sine wave starting at the left-hand edge of the screen has a -90° phase. Phase is displayed in degrees.

Power Density: Signal power normalized to the bandwidth of the equivalent filter associated with the FFT calculation, suitable for characterizing broadband noise. Power Density is displayed on a logarithmic vertical axis calibrated in dBm.

Magnitude: The peak signal amplitude is represented on a linear scale, in the same units as the input signal.

Real, Real + Imaginary:, Imaginary: complex result of the FFT processing in the same units as the input signal.

6. Make a selection for “with window” and press the button to select **AC**.

AC forces the DC component of the input signal to zero before FFT processing, and improves the amplitude resolution. This is especially useful when your input has a large DC component.

FFT windows define the bandwidth and shape of the FFT filter. (See Chapter 10, “Use Advanced Math Tools,” in the WavePro Operator’s Manual for the windows filter parameters.)

Von Hann (Hanning) windows reduce leakage and improve amplitude accuracy. But they also reduce frequency resolution.

Rectangular windows should be used when the signal is transient (completely contained in the time-domain window) or you know it to have a fundamental frequency component that is an integer multiple of the fundamental frequency of the window. Other signal types will show varying amounts of spectral leakage and scallop loss when you use a Rectangular window. To correct this use another window type.

Hamming reduces leakage and improves amplitude accuracy, but also reduces frequency resolution.

Flat Top provides excellent amplitude accuracy with moderate leakage reduction, but also reduces frequency resolution.

Blackman-Harris windows reduce leakage to a minimum, but reduce frequency resolution.

7. Set the “of” selection to the trace that is the JitterTrack on which you want to perform the JitterFFT.

Spectra will be shown with

a linear frequency axis running from zero to the Nyquist frequency. The frequency scale factors (Hz/div) are in a 1-2-5

sequence. The processing equation is displayed at the bottom of the screen, together with the three key parameters that characterize an FFT spectrum:

Transform size N (number of input points)

Nyquist frequency (= ½ sample rate)

Frequency increment, Delta f, between two successive points of the spectrum.

These parameters are related as:

$$\text{Nyquist frequency} = \text{Delta } f * n/2$$

where Delta f = 1/t and T is the duration of the input waveform record (10 * time/div). The number of output points is equal to N/2.

Note: During FFT computation, the FFT sign is shown below the grid. The computation can take a while on long time-domain records, but you can stop it at any time by pressing an front panel button.

§ § §



BLANK PAGE

How to Use Phase Demodulation

Phase Demodulation of a clock or datastream signal is accomplished with the JitterTrack of Time Interval Error (TIE) function (also included in the JitterTrack menu “type” listing). The JitterTrack of TIE measures the time difference between the edges of the acquired waveform relative to an ideal clock. It is ideal for extracting spread spectrum modulation frequency from a clock signal, or the analysis of communications systems employing continuous phase modulation as well as those using phase shift keying for transmitting digital data.

There are two methods to create a JitterTrack of TIE (phase demodulation) on the Jitter and Timing Analyzer. The easiest method is to use the Jitter Views toolbar Analysis button to access the Analysis menu. When this method is used, certain defaults are set, and the JitterFFT will be displayed as Trace C. This method is explained below:

1. Acquire a clock or data signal.
2. Press the Analysis button in the Jitter Views Toolbar and select Phase Demod from the menu.
3. Press MORE JITTER SETUP and either set the ideal clock frequency manually, or use the FIND FREQUENCY soft key. (In some cases, the FIND FREQUENCY routine may not return the frequency. If that happens, manually adjust the frequency to get close to where it should be and try again).

A JitterTrack of TIE can also be set up on any math trace by following the instructions below:

1. Press Math Tools.
2. Press the menu button to “REDEFINE D”, for example. This will place the JitterFFT on trace D.
3. Select **YES** from “Use Math” menu to enable math functions, including Jitter.
4. Choose **Jitter** from the “Math Type” menu.
5. Choose **Interval Error** from the “Type” menu.
6. Make a selection for **CLK** or **Data**.



Jitter and Timing Analyzer

7. Make a selection for the source “of”.
8. Use MORE JITTER SETUP to set the ideal frequency, or to FIND FREQUENCY.

§ § §

To Trace Persistence

Display a Persistence waveform on a LeCroy color digital instrument.

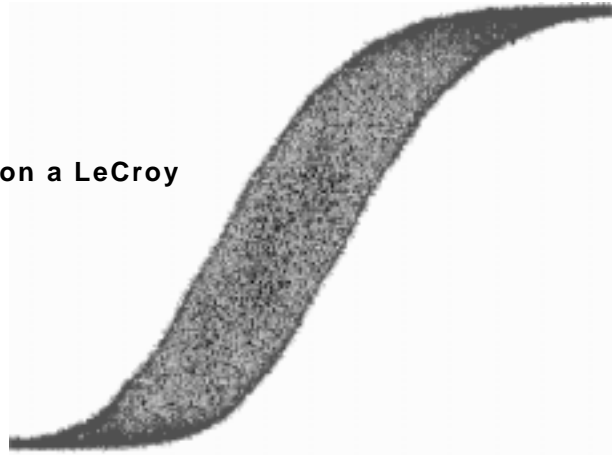

From this waveform, create any of three types of shapes on which waveform processing can be performed.



Average

Range

Sigma



An Innovative Visual AND Processing Tool

Persistence Trace (Per.Trace) empowers the instrument's Persistence display. With this Timing Function, not only can waveform noise and jitter be visualized, but further processing can be done — previously not possible with Persistence alone.

Per.Trace generates special graphic representations of the Persistence waveform on which further processing, such as the application of parameters and even PASS/FAIL testing, can be performed.

Displaying data acquired from multiple sweeps of the waveform, Per.Trace computes a vector trace based on the bit map of the underlying signal acquisitions. Detail is then shown in a choice of three shapes (*illustrated on the previous page*): “average”, “sigma” and “range”. These are created without destroying the underlying data, allowing visualization of analytical results from observation of raw data.

Typical applications and which of the three Per.Trace types to use for them are given in the table.

To...	Use Per.Trace...
See edge detail in a fast signal	<i>average</i>
Eliminate noise on a persistence trace	<i>average</i>
Assess “typical” noise on a persistence trace	<i>sigma</i>
Assess “worst case” noise on a persistence trace, and use it to create a tolerance mask	<i>range</i>

Set Up and Configure for Per.Trace

There are two methods to create a Persistence Trace on the Jitter and Timing Analyzer. The easiest method is to use the Jitter Views toolbar's **ANALYSIS** button to access the **Analysis** menu. When this method is used, the Persistence Trace will be displayed on Trace C.

To configure and display Persistence traces on any trace, use the method below:

1. **Acquire a trace in Persistence mode, using Analog Persistence.**

MATH
SETUP

2. Press  to display the ZOOM + MATH menus. They allow redefinition of any of the four traces, A, B, C and D and access their "SETUP" menus.

3. Press the  for "REDEFINE A", to configure the function — on Trace A for this example. Then select "**Per.Trace**" from the "Math Type" menu and use the menus shown here to create a Persistence Trace.

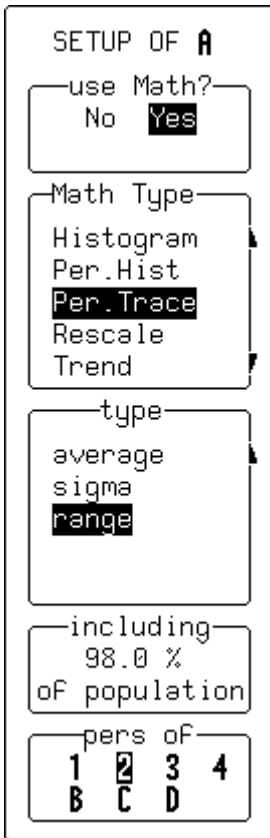

use Math?

To choose a math function.

Math Type

For selecting "**Per.Trace**".

type

To select the type of Persistence Trace: "**average**", "**sigma**" or "**range**".

including/scale to

When "**range**" is selected, as in this example, a percentage of the population of the persistence map can be chosen from which the envelope will be formed, enabling exclusion of infrequent events (artifacts).

When "**sigma**" is highlighted, this becomes the "scale to" menu, which allows selection of a sigma factor of from 0.5–10.0. Expands those parts of the sigma envelope representing waveform regions with the most jitter.

When "**average**" is selected, this menu does not appear at all.

pers of

For selecting the source trace to which the Persistence Trace Function is to be applied.



How To Trace Persistence

average

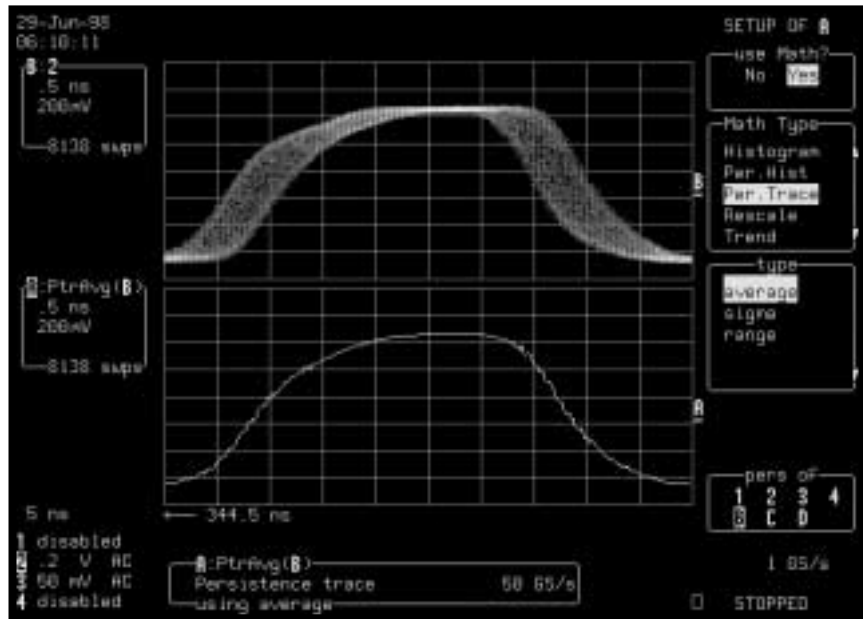

Persistence Trace: average. For each vertical time slice on the persistence map, calculates and plots a trace corresponding to the map's mean value. Single-shot signals sampled at or above 2 GS/s and accumulated in the persistence map can be traced at a resolution of 10 ps (100 GS/s equivalent sampling). The Per.Trace average may be further analyzed using the instrument's standard parameters such as rise time.

sigma

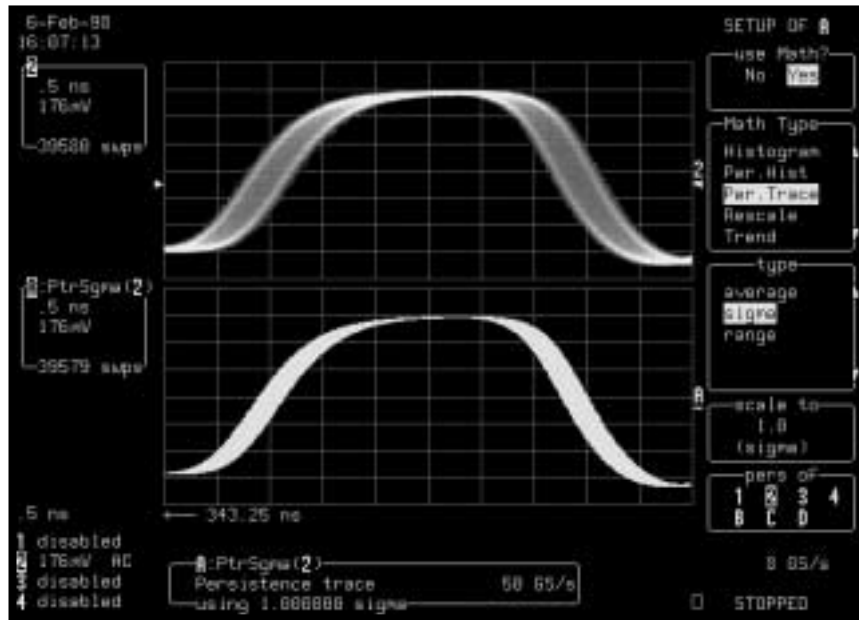

Persistence Trace: sigma. For each vertical time slice on the persistence map, calculates and plots an envelope corresponding to the map's standard deviation. Multiples of sigma can also be done using sigma.

range

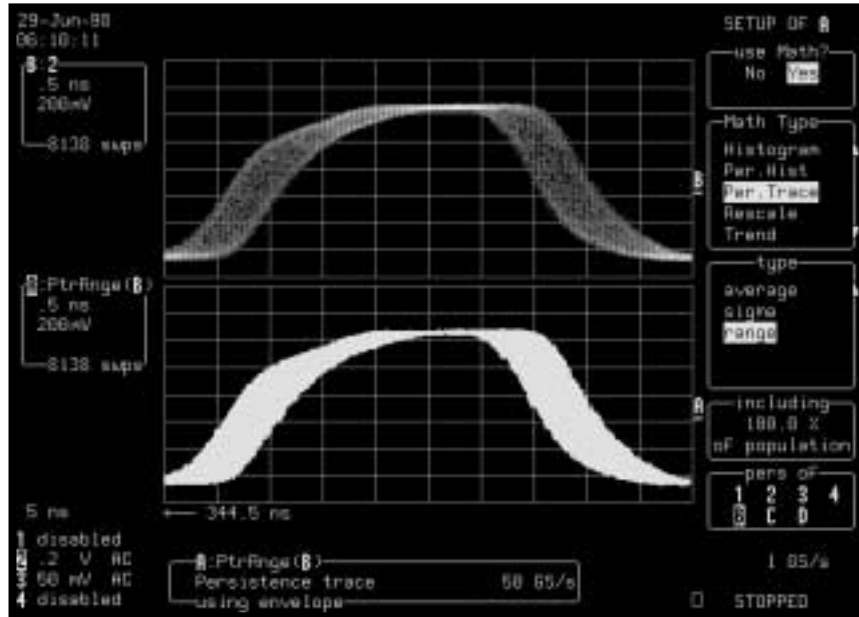

Persistence Trace: range. For each vertical time slice on the persistence map, calculates and plots an envelope corresponding to the map's range. The Per.Trace range can then be used in further processing: for example, as a source for Pass/Fail masks.

§ § §

How "Per. Hist" Reveals Hidden Features

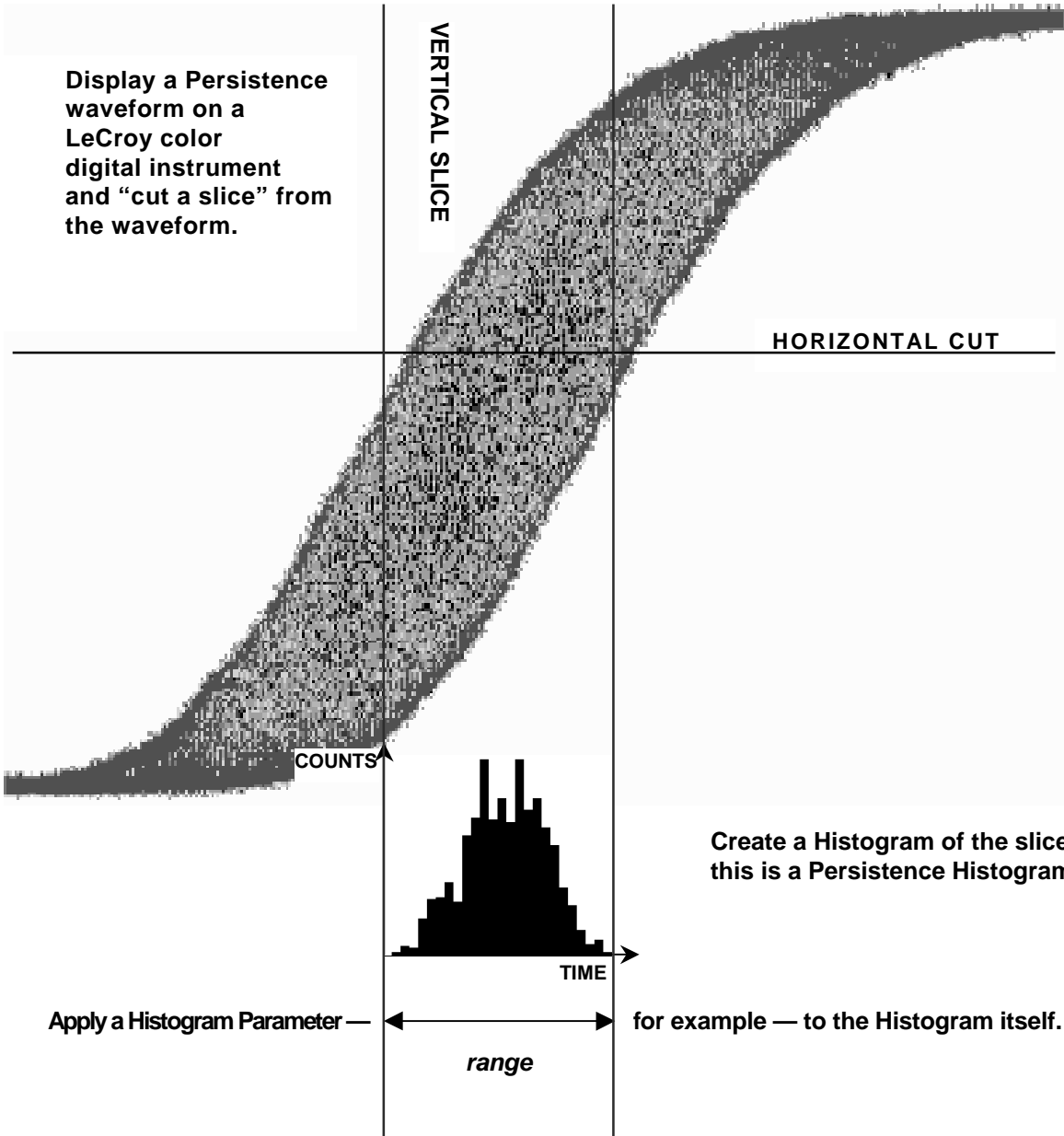



Why *Persistence* Histograms and When

The Persistence Histogram Function, **Per.Hist**, builds the histogram from a persistence map* to reveal the features that only exist when several acquisitions have been superimposed on one another. In contrast to this, the Histogram as Statistical Tool (see *Chapter 6*) simply graphs waveform parameters such as amplitude, frequency or pulse width on an acquisition or series of acquisitions.

Both Histogram and Persistence Histogram bar charts are divided into intervals, or bins. But whereas each bin in the Histogram bar chart contains a class of similar parameter values, **Per.Hist** analyzes both vertical and horizontal “slices” of the persistence map. Vertically, each bin contains a class of similar *amplitude* levels; horizontally, a class of similar *time* values.

For a Histogram of...	Use...
A crossover point in time or in amplitude on an eye diagram...	Per.Hist. (Vert. and Horiz. Slices)
Cumulative jitter on an eye diagram...	Per.Hist (Horiz. Slice)
Signal-to-noise ratio on an eye diagram...	Per.Hist. (Vert. Slice)
The different interval widths present in a long data stream...	Histogram (of Timing Parameter $p@N$)
Cumulative jitter on a long record of a clock signal...	Histogram (of Timing Parameter $tie@N$)
Cycle-to-cycle jitter...	Histogram (of $\Delta p@N$)



* Persistence maps are generated using the Persistence function on LeCroy color digital instruments.

Set Up and Configure for Per.Hist

There are two methods to create a Persistence Trace on the Jitter and Timing Analyzer. The easiest method is to use the Jitter Views toolbar's **ANALYSIS** button to access the **Analysis** menu. When this method is used, the Persistence Trace will be displayed on Trace C. To configure and display Persistence traces on any trace, use the method below:

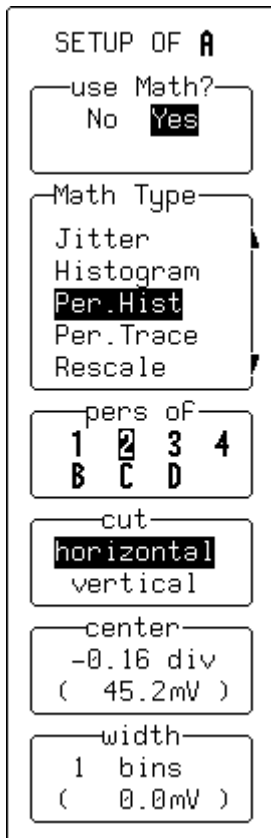
1. **Acquire a trace in Persistence mode, using LeCroy Analog Persistence.**



2. Press  to display the ZOOM + MATH menus. They allow redefinition of any of the four traces, A, B, C and D and access their "SETUP" menus.
3. Press the  for "REDEFINE A", to configure the function — on Trace A for this example. Then select "Per.Hist" from the "Math Type" menu and use the menus shown here to create a Persistence Histogram.

use Math?

To choose a math function.

Math Type

For selecting "Per.Hist".

pers of

For selecting the source trace to be histogrammed.

cut

To select to cut a horizontal or vertical slice of the persistence waveform for histogramming. Here, "horizontal" has been selected, which means that the parenthesized values set in the "center" and "Width" menus, *below*, will be expressed in units of amplitude. When "vertical" is highlighted, the same values will be expressed in units of time, and in pixels.)

center

To position the cut on the persistence waveform: a pair of dedicated line cursors appear for visualizing and positioning the "slice", controlled with the corresponding menu knob. Pressing the menu button causes the cursor to revert to the middle of the grid.



How To Use Persistence Histograms

width

To set the width of the “slice”: a pair of dedicated line cursors appear for visualizing and setting the width of the cut, controlled using the corresponding menu knob. The menu button causes the width to revert to zero. (The “bins” referred to in this menu when horizontal cuts are made are *not* histogram bins, but rather eight-bit ADC bins.)

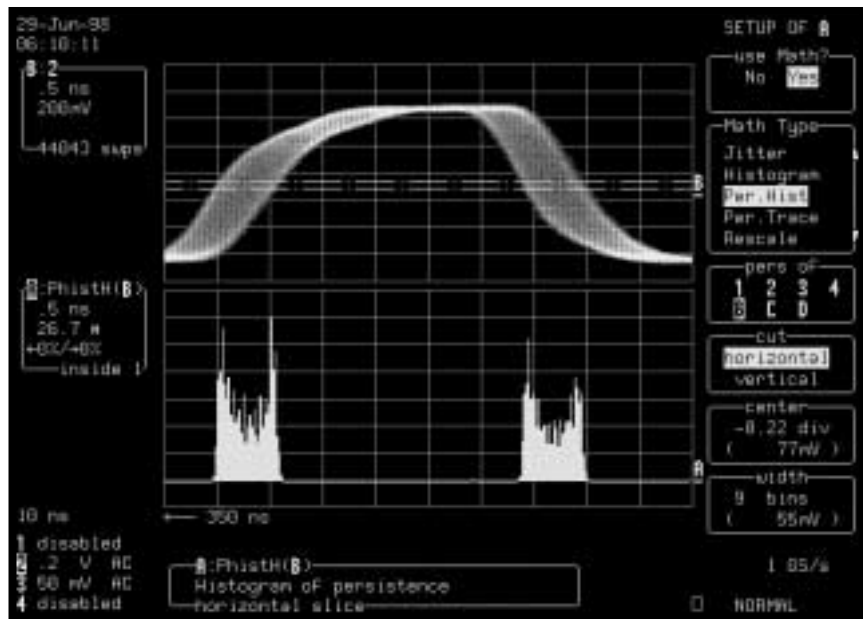

Persistence Histogram, horizontal cut. The horizontal “slice” has been “cut” using the cursors set with the center and width menus. Note the exact alignment of the bar chart sections on Trace A with the sliced Persistence waveform region on each occasion that the cursors intersect the waveform. The Per.Hist Function may be further analyzed using either the instrument’s standard measurement cursors or Histogram Parameters.

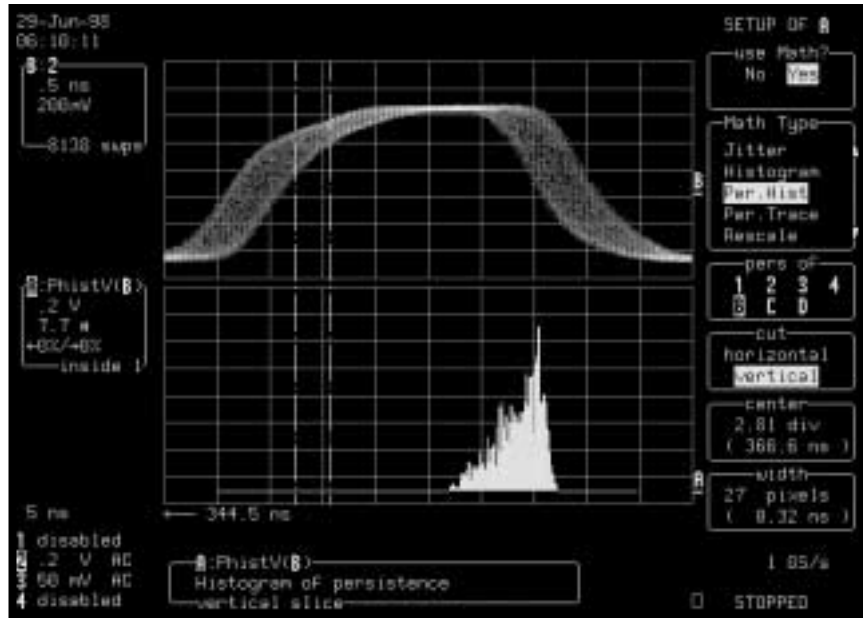

Persistence Histogram, vertical cut. The “slice” has been “cut” using the cursors set with the center and width menus. With vertical cuts, the bar chart on Trace A is unaligned with the slice of the Persistence waveform (this is because low-amplitude bins are displayed at left, and high-voltage bins at right, of the grid). The Per.Hist Function may be further analyzed using either the instrument’s standard measurement cursors or Histogram Parameters.

§ § §



How To Use Persistence Histograms

BLANK PAGE

How to Use the Trend Tool

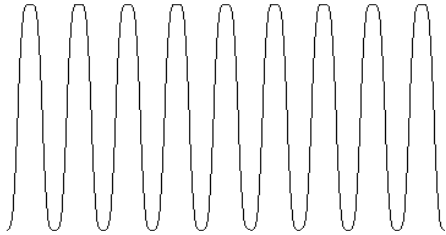

Display the waveform to be analyzed.

Apply a Timing Parameter — *period at level (p@lv)*, for example.

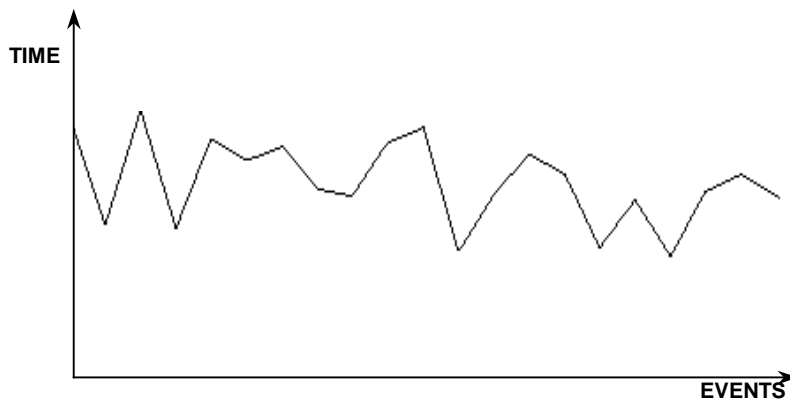
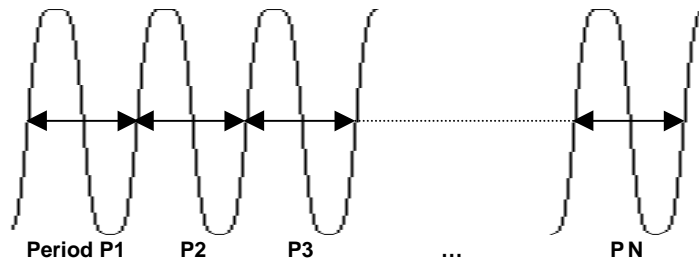

Plot the Trend of the Parameter.



Set Up and Configure for Trends

The Trend Statistical Tool visualizes the evolution of a Timing Parameter over time in the form of a line graph. The graph's vertical axis is the value of the parameter; its horizontal axis the order in which values were acquired.



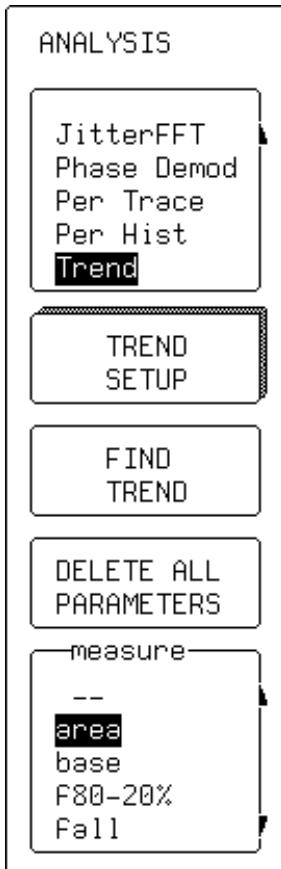

There are two methods to create a trend on the Jitter and Timing Analyzer. The easiest method is to use the Jitter Views toolbar Analysis button to access the Analysis menu. When this method is used, the trend will be displayed on Trace C. This method is explained below:

1. **Acquire a trace on the display**
2. **Use the Horizontal Time/Div knob to adjust the waveform, if desired so that you view the area that you wish to trend.**
3. **Press the **ANALYSIS** button in the Jitter Views Toolbar and select Trend from the menu.**
4. **Press **TREND SETUP** and select the number of values to be contained in the trend.**
5. **Press More Trend Setup and Parameter Setup to select a parameter to be trended.**
6. **Trigger the analyzer until the required number of values have been trended.**

Note: This method assumes that you want to trend the Timing Parameter for the Jitter type as previously defined in the Setup Wizard menu.



To configure and then display trends, follow these steps:

1. Press  MATH SETUP
2. Then press the menu button  for "REDEFINE A" — for example. This will place the Trend on Trace A.
3. Select "Yes" from the "use Math?" menu to enable math functions, including trending (*see following pages for menus*).
4. Choose "Trend" from the "Math Type" menu.
5. Select the line to be used in the Trend.
6. Choose the number of values to be placed in the generated Trend
7. Decide whether all the parameters generated from the waveform or only the average of all parameter calculations for each waveform acquisition should be placed in the Trend.
8. For more Timing Parameters, press  or turn  to obtain the parameter in the "Histogram custom line" menu.
9. Press the appropriate TRACE ON/OFF button  to display the Trend.
10. Select the "FIND CENTER AND WIDTH" menu to position the Trend automatically.



use Math?

To choose a math function.

Math Type

For selecting "Trend".

MORE TREND SETUP

To access more trend setup options and the final trend-dedicated menu (*next page*).

FIND CENTER AND HEIGHT

For positioning the trend automatically once it has been calculated. "FIND CENTER AND HEIGHT" places the trace appropriately, centering and scaling the trend without affecting the zoom and position settings.

Trend of

To select the parameter for trending, using the corresponding menu button or associated knob. Any of the configured parameters, displayed on the line beneath the grid, can be chosen.

using up to

For selecting — using button or knob — the number of values in the trend. A maximum of 20 000 values can be chosen for any one trend. When this maximum is exceeded, the parameter results scroll off the trend.

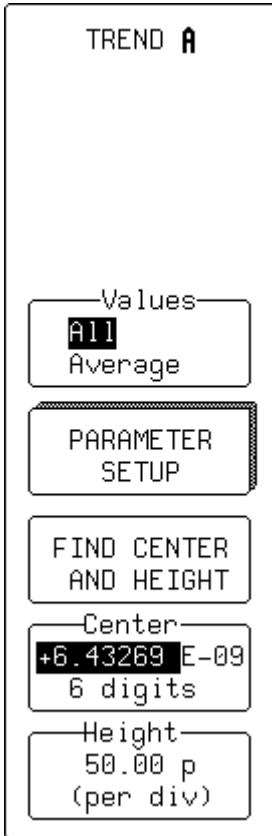

Values

To select "All" — for every parameter calculation on each waveform to be placed in the trend. Or "Average" — to trend only the average of all the given values calculated on a given acquisition, and to obtain one point in the trend per acquisition. Unless this is specifically required, "All" should be selected.

PARAMETER SETUP

To access the "CHANGE PARAM" menu group for selection of new, or modification of current, Timing Parameters.

FIND CENTER AND HEIGHT

For positioning the trend automatically once calculated. "FIND CENTER AND HEIGHT" places the trace appropriately, centering and scaling the trend without affecting the zoom and position settings.

Center

To set the trend center value.

Height

To select the value of each vertical display division. The height per division multiplied by the number of vertical display divisions (eight) determines the range of parameter values centered on the number in the "Center" menu, used to create the trend.



Reading Trends: A trend is like any other waveform: its horizontal axis is in units of events with earlier events in the leftmost part of the waveform and later events to the right. And its vertical axis is in the same units as the trended parameter. When the trend is displayed, trace labels like the ones below — for Trace A in these examples — appear in their customary place on-screen, identifying the trace, the math function performed and giving horizontal and vertical information...

```
A:Tamp1(1)
20 #
200 µV
49.731mV
inside 200
```

number of events per horizontal division

Units per vertical division, in units of the parameter being measured

Vertical value at point in trend at cursor location when using cursors

Number of events in trend that are within unzoomed horizontal display range.

```
A:Tamp1(1)
20 #
200 µV
↓1%/↑0%
inside 193
```

Percentage of values lying beyond the unzoomed vertical range when *not* in cursor measurement mode.

Note for Display of Trends:

☞ The display of defined traces is controlled by the TRACE ON/OFF buttons.



☞ Expansion, or zooming, and positioning of traces is controlled by the horizontal and vertical ZOOM and POSITION knobs.

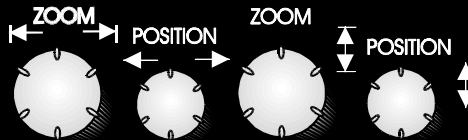

☞ When Multi-zoom is on, the ZOOM and POSITION knobs are coupled and control all displayed traces at once. This is particularly useful when multiple trends of related parameters are displayed.

RESET

☞ The  button resets the multiplier for the trace expansion to '1' and the offset positioning to '0'. The button should be pressed for each reconfigured trace in order that traces can be cleanly and correctly positioned on-screen.

§ § §



BLANK PAGE

Histogram and Trend Calculation

With the instrument configured for *Histograms* or *Trends* (as described in previous chapters), the timing parameter values are calculated and the chosen function performed on each subsequent acquisition. The *Histogram* or *Trend* values themselves are calculated immediately following each acquisition.

The result is a waveform of data points that can be used the same way as any other waveform. Other parameters can be calculated on it, it can be zoomed, serve as the **x** or **y** trace in an **XY** plot, or used in cursor measurements.

Acquisition Sequence

The sequence for acquiring *Histogram* or *Trend* data is:

1. Trigger
2. Waveform Acquisition
3. Parameter Calculation(s)
4. Histogram Update
5. Trigger re-arm.

If the timebase is set in non-segmented mode, a single acquisition occurs prior to parameter calculations.

However, in segment mode an acquisition for each segment occurs prior to parameter calculations. If the source of *Histogram* or *Trend* data is a memory, storing new data to memory effectively acts as a trigger and acquisition. Because updating the screen can take significant processing time, it occurs only once a second, minimizing trigger dead-time. (Under remote control, the display can be turned off to maximize measurement speed.)

Parameter Buffer

The instrument maintains a circular parameter buffer of the last 20 000 measurements made, including values that fall outside the set histogram range. If the maximum number of events to be used in a histogram or trend is a number **N** less than 20 000, the histogram will be continuously updated with the last **N** events as new acquisitions occur. If the maximum number is greater than 20 000, the histogram or trend will be updated until the number of



events is equal to **N**. Then, if the number of bins or the histogram or trend range is modified, the instrument will use the parameter buffer values to redraw the histogram with either the last **N** or 20 000 values acquired, whichever is the lesser. The parameter buffer thereby allows histograms or trends to be redisplayed using an acquired set of values and settings that produce a distribution shape with the most useful information.

In many cases the optimal range is not readily apparent, so the instrument has a powerful range-finding function. If required, it will examine the values in the parameter buffer to calculate an optimal range and redisplay the histogram or trend using it. The instrument will also give a running count of the number of parameter values that fall within, below and above the range. If any fall below or above the range, the range-finder can then recalculate to include these parameter values, as long as they are still within the buffer.

Parameter Events Capture The number of events captured per waveform acquisition or display sweep depends on the type of parameter. Acquisitions are initiated by the occurrence of a trigger event. Sweeps are equivalent to the waveform captured and displayed on an input channel (**1, 2, 3 or 4**).

For non-segmented waveforms, an acquisition is identical to a sweep, but for segmented waveforms an acquisition occurs for each segment and a sweep is equivalent to acquisitions for all segments. Only the section of a waveform between the parameter cursors is used in the calculation of parameter values and corresponding histogram events.

The following table provides a summary of the number of *Histogram* or *Trend* events captured per acquisition or sweep for each parameter and for a waveform section between the parameter cursors.

Appendix A: More On Histograms and Trends

Parameter	Number of Events Captured
Timing Parameters: p@lv, freq@lv, wid@lv, Δp@lv, edge@lv, duty@lv, tie@lv, skew@lv, setup@lv, hold@lv	Unlimited number of events per acquisition.
data	All data values in the region analyzed.
duty, freq, period, width,	Up to 49 events per acquisition.
ampl, area, base, cmean, cmedian, crms, csdev, cycles, delay, dur, first, last, maximum, mean, median, minimum, nbph, nbpw, over+, over-, phase, pkpk, points, rms, sdev, Δdly, Δt@lv	One event per acquisition.
f@level, f80–20%, fall, r@level, r20–80%, rise	Up to 49 events per acquisition.

Zoom Traces and Segmented Waveforms

Histograms and Trends of zoom traces display all events for the displayed portion of a waveform between the parameter cursors. When dealing with segmented waveforms, and when a single segment is selected, the histogram or trend will be recalculated for all events in the displayed portion of this segment between the parameter cursors. But if **All Segments** is selected, the histogram or trend for all segments will be displayed.

Histogram Peaks

Because the shape of histogram distributions is particularly interesting, additional parameter measurements are available for analyzing these distributions. They are generally centered on one of several peak value bins, known — together with its associated bins — as a histogram peak.

Example:

A histogram of the voltage value of a five-volt amplitude square wave is centered on two peak value bins: **0 V** and **5 V** (Fig. A–1). The adjacent bins signify variation due to noise. The graph of the centered bins shows both as peaks.

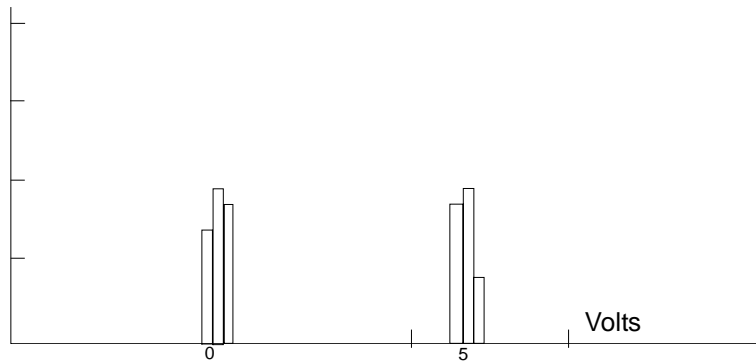

Fig. A-1

Determining such peaks is very useful, as they indicate dominant values of a signal.

However, signal noise and the use of a high number of bins relative to the number of parameter values acquired, can give a jagged and spiky histogram, making meaningful peaks hard to distinguish. The instrument analyzes histogram data to identify peaks from background noise and histogram definition artifacts such as small gaps, which are due to very narrow bins.

Binning and Measurement Accuracy

Histogram bins represent a sub-range of waveform parameter values, or events. The events represented by a bin may have a value anywhere within its sub-range. However, parameter measurements of the histogram itself, such as **average**, assume that all events in a bin have a single value. The instrument uses the center value of each bin's sub-range in all its calculations. The greater the number of bins used to subdivide a histogram's range, the less the potential deviation between actual event values and those values assumed in histogram parameter calculations.

Nevertheless, using more bins may require performance of a greater number of waveform parameter measurements, in order to populate the bins sufficiently for the identification of a characteristic histogram distribution.

Appendix A: More On Histograms and Trends

Figure A-2 shows a histogram display of 17 999 parameter measurements divided or classified into 2000 bins. The standard deviation of the histogram sigma is 6.750 ps.

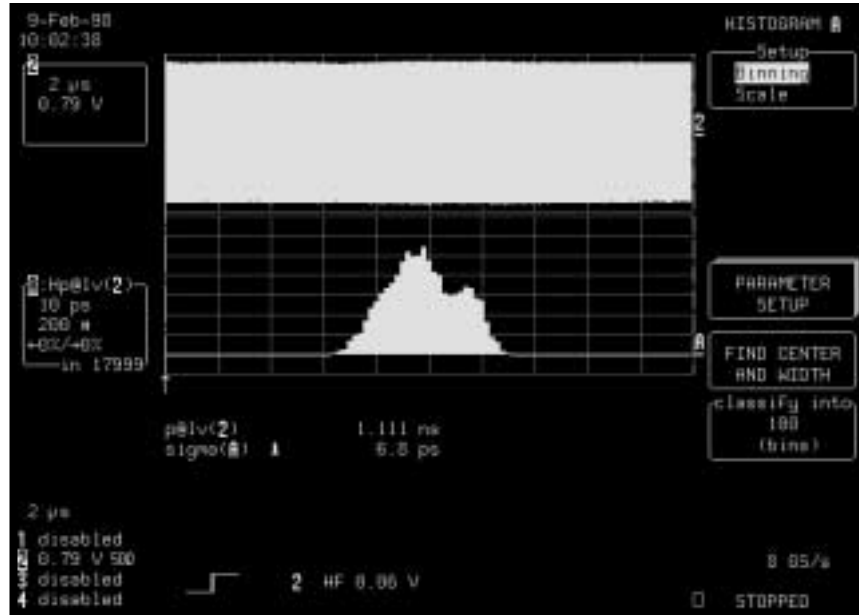

Fig. A-2 – Note the histogram's jagged appearance.

The instrument's parameter buffer (see page A-1) is very effective for determining the optimal number of bins to be used. An optimal bin number is one where the change in parameter values is insignificant, and the histogram distribution does not have a jagged appearance. With this buffer, a histogram can be dynamically redisplayed as the number of bins is modified by the user. In addition, depending on the number of bins selected, the change in waveform parameter values can be seen.

In Figure A-3, the histogram shown in the previous figure has been recalculated with 100 bins. Note how it has become far less jagged, while the real peaks are more apparent. Also, the change in sigma is minimal (6.750 ps vs 6.8 ps).

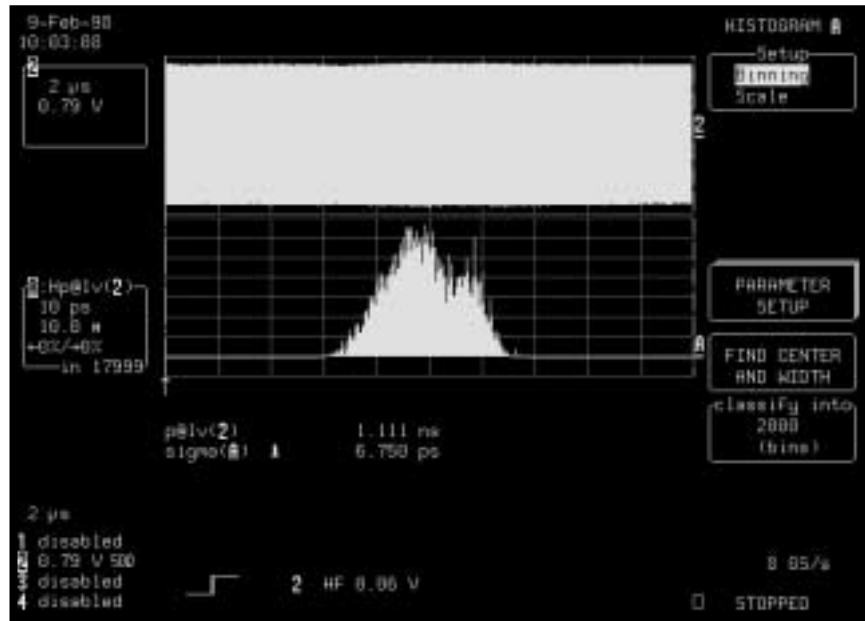

Fig. A-3

§ § §

avg**Average****Definition**

Average or mean value of data in a histogram.

Description

The average is calculated by the formula:

$$\text{avg} = \frac{\sum_{i=1}^n (\text{bin count})_i (\text{bin value})_i}{\sum_{i=1}^n (\text{bin count})_i},$$

where **n** is the number of bins in the histogram, **bin count** is the count or height of a bin, and **bin value** is the center value of the range of parameter values a bin can represent.

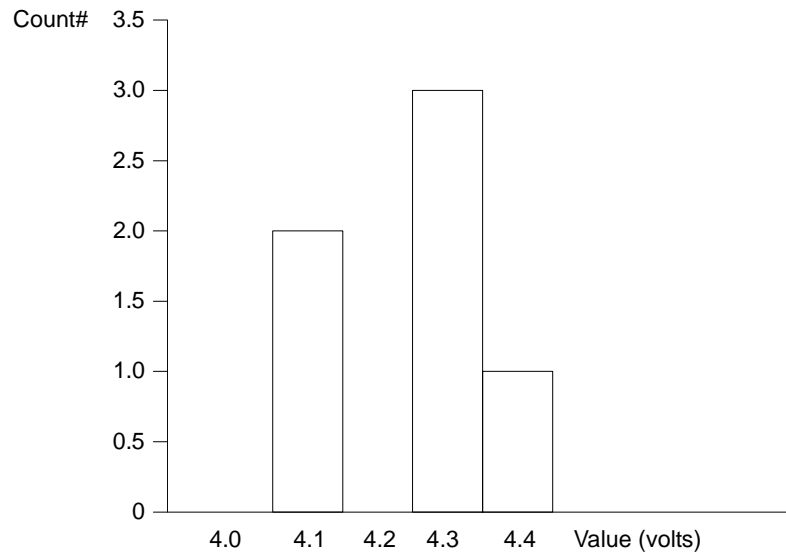
Example:

The average value of this histogram is:

$$(4.1 * 2 + 4.3 * 3 + 4.4 * 1) / 6 = 4.25.$$

fwhm

Full Width at Half Maximum

Definition

Determines the width of the largest area peak, measured between bins on either side of the highest bin in the peak that have a population of half the highest's population. If several peaks have an area equal to the maximum population, the leftmost peak is used in the computation.

Description

First, the highest population peak is identified and the height of its highest bin (population) determined. (For a discussion on how peaks are determined, see the **pks** parameter description.) Next, the populations of bins to the right and left are found, until a bin on each side is found to have a population of less than 50% of that of the highest bin's. A line is calculated on each side, from the center point of the first bin below the 50% population to the center point of the adjacent bin, towards the highest bin. The intersection points of these lines with the 50% height value is then determined. The length of a line connecting the intersection points is the value for **fwhm**.

Example:

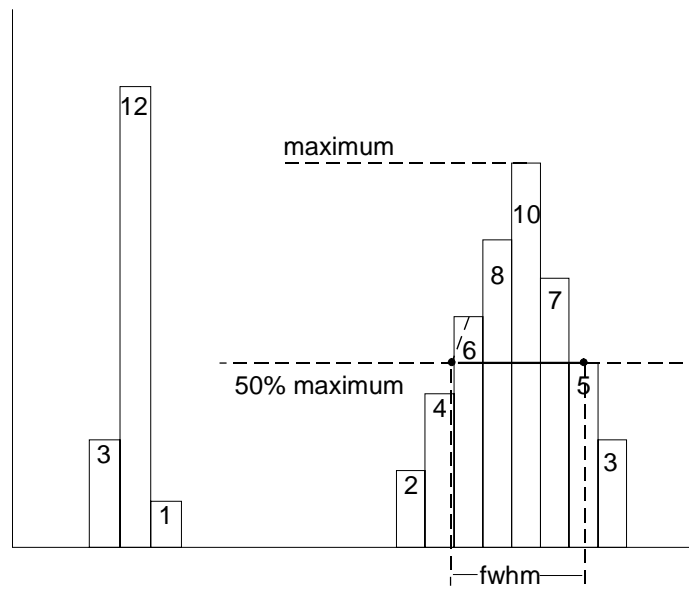

fwxx

Full Width at xx% Maximum

Definition

Determines the width of the largest area peak, measured between bins on either side of the highest bin in the peak that have a population of xx% of the highest's population. If several peaks have an area equal to the maximum population, the leftmost peak is used in the computation.

Description

First, the highest population peak is identified and the height of its highest bin (population) determined. (See the **pks** description.) Next, the bin populations to the right and left are found until a bin on each side is found to have a population of less than xx% of that of the highest bin. A line is calculated on each side, from the center point of the first bin below the 50% population to that of the adjacent bin, towards the highest bin. The intersection points of these lines with the xx% height value is then determined. The length of a line connecting the intersection points is the value for **fwxx**.

Parameter Settings

Selection of the **fwxx** parameter in the **CHANGE PARAM** menu group causes the **MORE fwxx SETUP** menu to appear. Pressing the corresponding menu button displays a threshold setting menu that enables the user to set the **xx** value to between 0 and 100% of the peak.

Example

fwxx with threshold set to 35%:

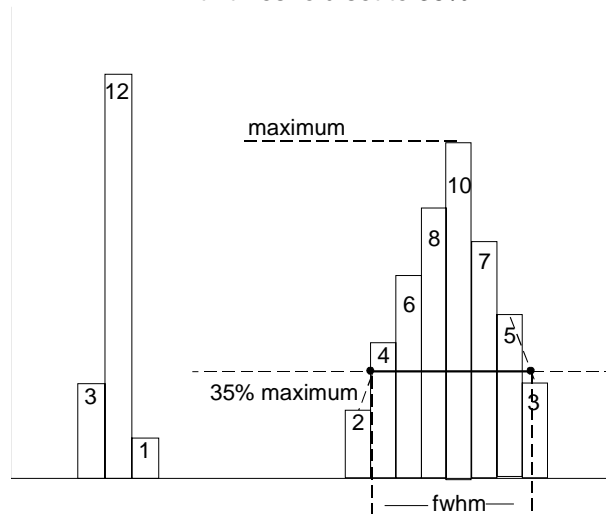

hampl

Histogram Amplitude

Definition

The difference in value of the two most populated peaks in a histogram. This parameter is useful for waveforms with two primary parameter values, such as TTL voltages, where **hampl** would indicate the difference between the binary "1" and "0" voltage values.

Description

The values at the center (line dividing the population of peak in half) of the two highest peaks are determined. (See **pks** parameter description.) The value of the leftmost of the two peaks is the histogram base (See **hbase**), while that of the rightmost is the histogram top (See **htop**). The parameter is then calculated as:

$$\text{hampl} = \text{htop} - \text{hbase}$$

Example:

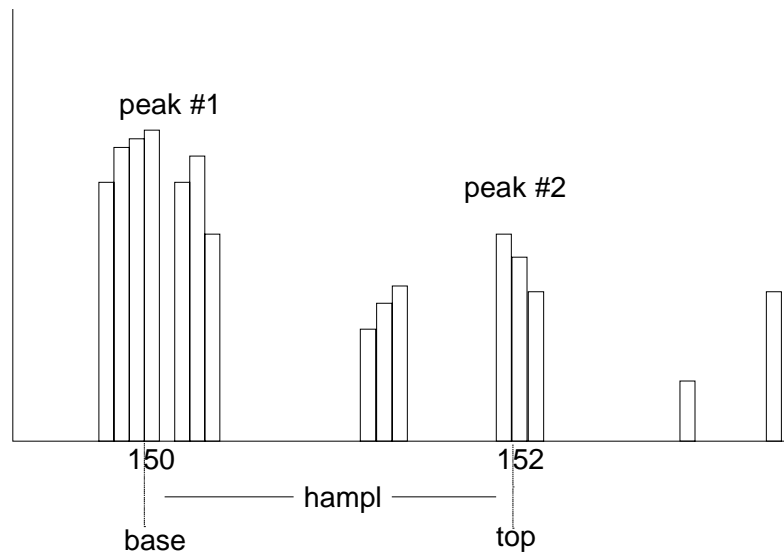

In this histogram, **hampl** is $152 \text{ mV} - 150 \text{ mV} = 2 \text{ mV}$.

Hbase

Histogram Base

Definition

The value of the leftmost of the two most populated peaks in a histogram. This parameter is primarily useful for waveforms with two primary parameter values such as TTL voltages where **hbase** would indicate the binary "0" voltage value.

Description

The two highest histogram peaks are determined. If several peaks are of equal height, the leftmost peak among these is used (see **pks**). Then the leftmost of the two identified peaks is selected. This peak's center value (line that divides population of peak in half) is the **hbase**.

Example:

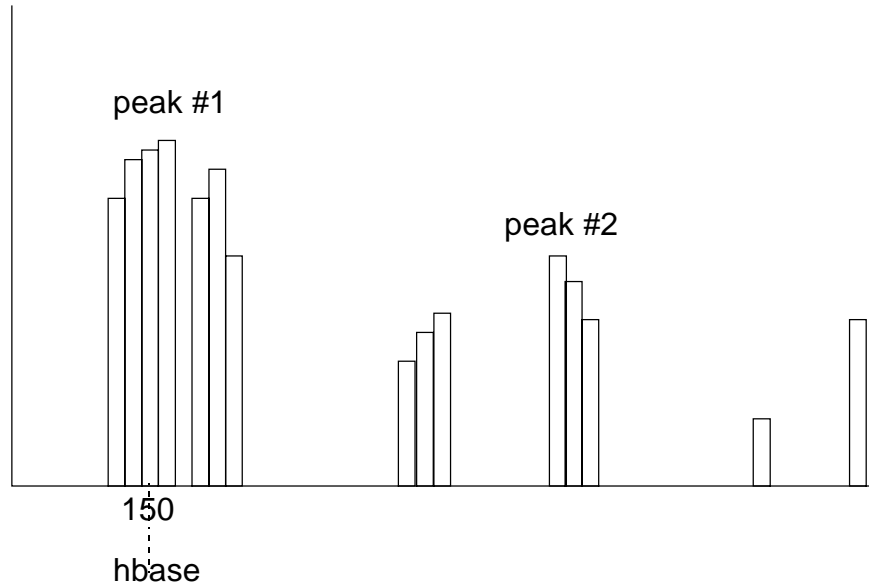

high

High

Definition

The value of the rightmost populated bin in a histogram.

Description

The rightmost of all populated histogram bins is determined: **high** is its center value, the highest parameter value shown in the histogram.

Example:

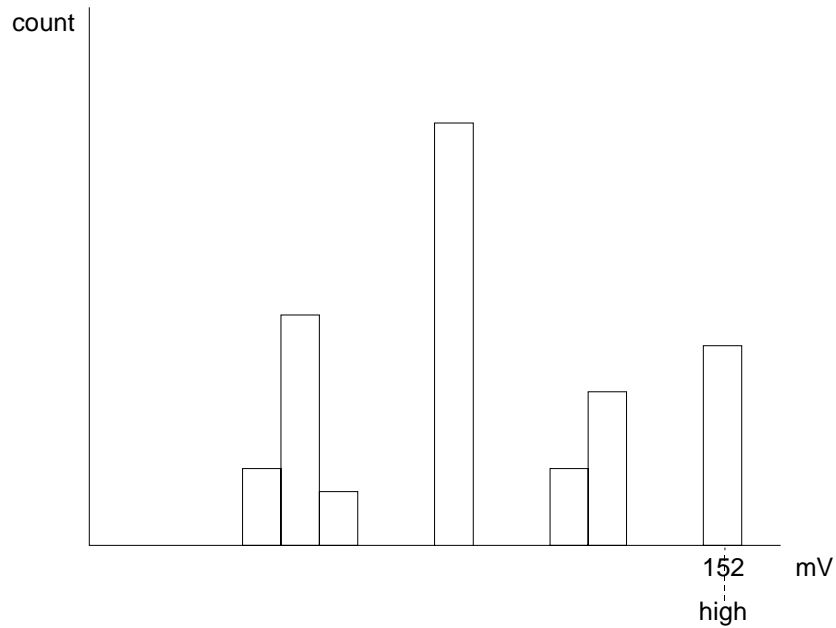

In this histogram **high** is 152 mV.

hmedian

Histogram Median

Definition

The value of the **x** axis of a histogram, dividing the histogram population into two equal halves.

Description

The total population of the histogram is determined. Scanning from left to right, the population of each bin is summed until a bin that causes the sum to equal or exceed half the population value is encountered. The proportion of the population of the bin needed for a sum of half the total population is then determined. Using this proportion, the horizontal value of the bin at the same proportion of its range is found, and returned as **hmedian**.

Example:

The total population of a histogram is 100 and the histogram range is divided into 20 bins. The population sum, from left to right, is 48 at the eighth bin. The population of the ninth bin is 8 and its sub-range is from 6.1 to 6.5 V. The ratio of counts needed for half- to total-bin population is:

$$2 \text{ counts needed} / 8 \text{ counts} = .25$$

The value for **hmedian** is:

$$6.1 \text{ volts} + .25 * (6.5 - 6.1) \text{ volts} = 6.2 \text{ volts}$$

hrms

Histogram Root Mean Square

Definition

The **rms** value of the values in a histogram.

Description

The center value of each populated bin is squared and multiplied by the population (height) of the bin. All results are summed, and the total is divided by the population of all the bins. The square root of the result is returned as **hrms**.

Example:

Using the histogram shown here, the value for **hrms** is:

$$\text{hrms} = \sqrt{(3.5^2 * 2 + 2.5^2 * 4) / 6} = 2.87$$

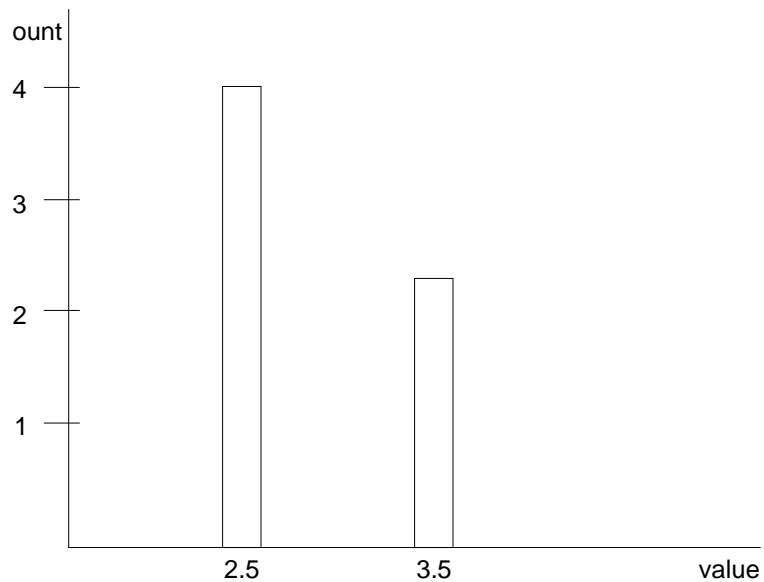

htop

Histogram Top

Definition

The value of the rightmost of the two most populated peaks in a histogram. This parameter is useful for waveforms with two primary parameter values, such as TTL voltages, where **htop** would indicate the binary "1" voltage value.

Description

The two highest histogram peaks are determined. The rightmost of the two identified peaks is then selected. The center of that peak is **htop**. (Center is the horizontal point where the population to the left is equal to the area to the right.)

Example:

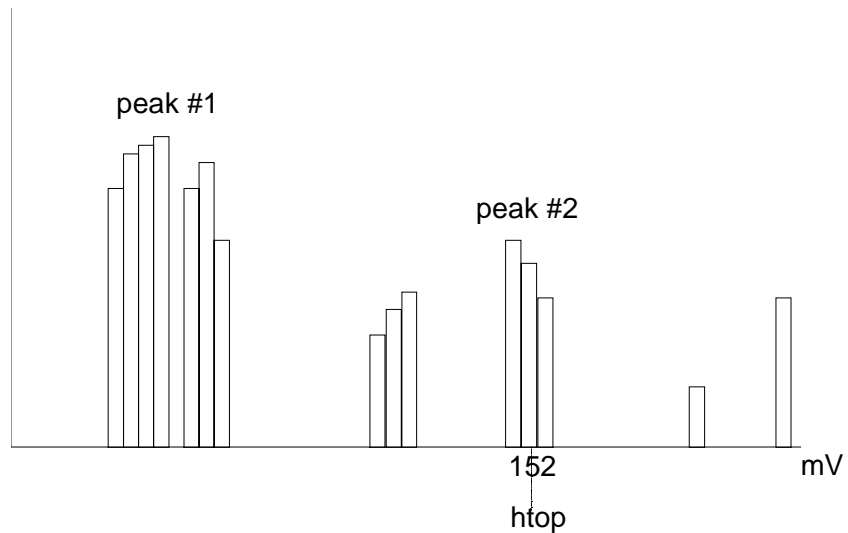

low

Low

Definition

The value of the leftmost populated bin in a histogram population. It indicates the lowest parameter value in a histogram's population.

Description

The leftmost of all populated histogram bins is determined. The center value of that bin is **low**.

Example:

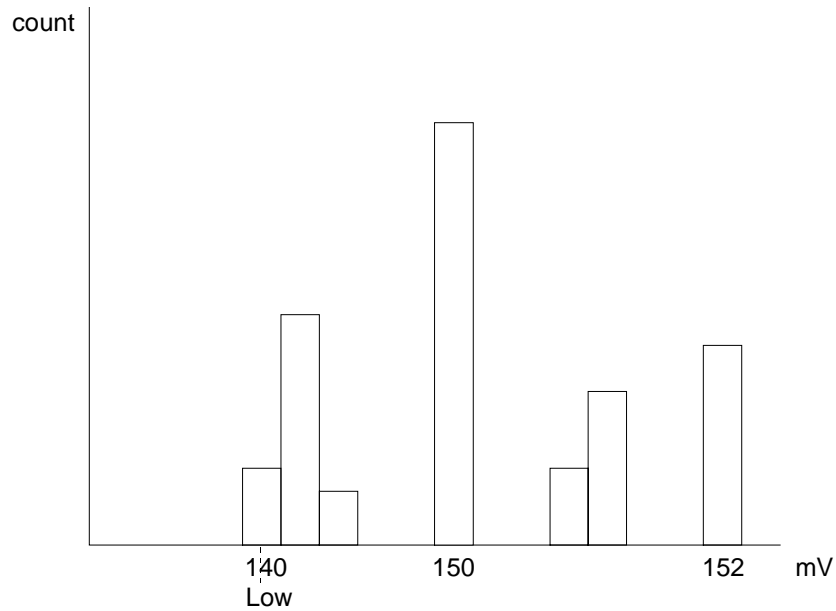

In this histogram **low** is 140 mV.

maxp

Maximum Population

Definition

The count (vertical value) of the highest population bin in a histogram.

Description

Each bin between the parameter cursors is examined for its count. The highest count is returned as **maxp**.

Example:

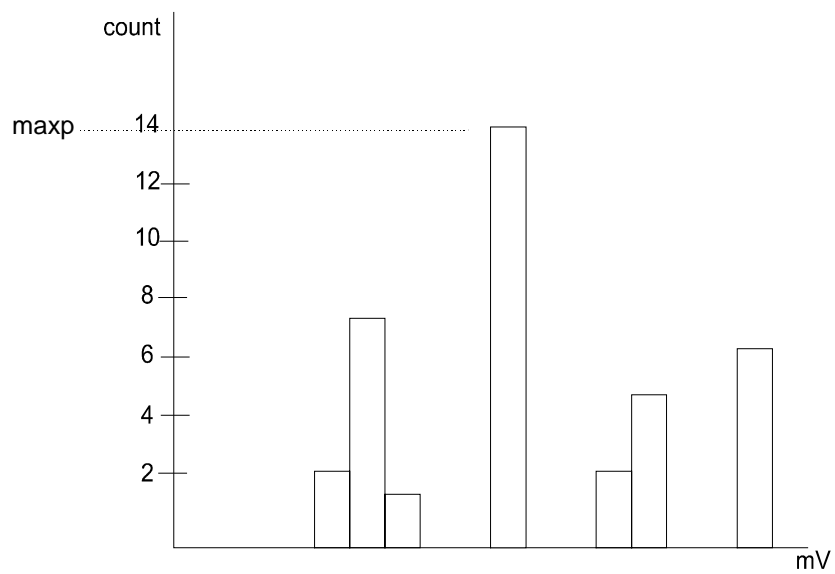

In this example, **maxp** is 14.

mode

Mode

Definition

The value of the highest population bin in a histogram.

Description

Each bin between the parameter cursors is examined for its population count. The leftmost bin with the highest count found is selected. Its center value is returned as **mode**.

Example:

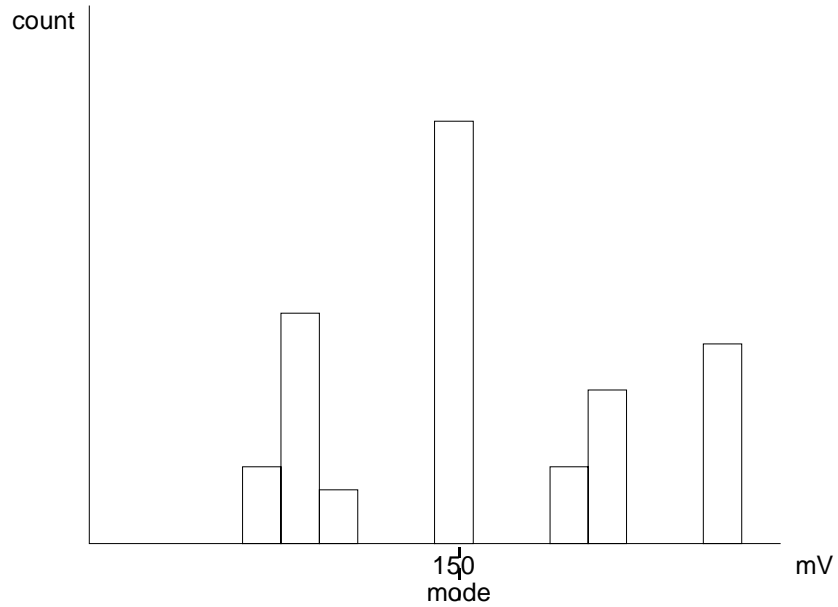

In this example **mode** is 150 mV.

pctl

Percentile

Definition

Computes the horizontal data value that separates the data in a histogram, so that the population on the left is a specified percentage, **xx** of the total population. When the threshold is set to 50%, **pctl** is the same as **hmedian**.

Description

The total population of the histogram is determined. Scanning from left to right, the population of each bin is summed until a bin that causes the sum to equal or exceed **xx%** of the population value is encountered. A ratio of the number of counts needed for **xx%** population/total bin population is then determined for the bin. The horizontal value of the bin at that ratio point of its range is found, and returned as **pctl**.

Example:

The total population of a histogram is 100. The histogram range is divided into 20 bins and **xx** is set to 25%. The population sum at the sixth bin from the left is 22. The population of the seventh is 9, and its sub-range is 6.1 to 6.4 V. The ratio of counts needed for 25% population to total bin population is:

$$3 \text{ counts needed} / 9 \text{ counts} = 1/3.$$

The value for **pctl** is:

$$6.1 \text{ volts} + .33 * (6.4 - 6.1) \text{ volts} = 6.2 \text{ volts}.$$

Parameter Settings

Selection of the **pctl** parameter in the **CHANGE PARAM** menu group causes the **MORE pctl SETUP** menu to appear. Pressing the corresponding menu button displays a threshold setting menu. With the associated knob, the user can set the percentage value to between 1% and 100% of the total population.

pks

Peaks

Definition

The number of peaks in a histogram.

Description

The instrument analyzes histogram data to identify peaks from background noise and histogram binning artifacts such as small gaps.

Peak identification is a three-step process:

1. The mean height of the histogram is calculated for all populated bins. A threshold (T1) is calculated from this mean where:

$$T1 = \text{mean} + 2 \sqrt{\text{mean}}$$

2. A second threshold is determined based on all populated bins under T1 in height, where:

$$T2 = \text{mean} + 2 * \text{sigma},$$

and where sigma is the standard deviation of all populated bins under T1.

3. Once T2 is defined, the histogram distribution is scanned from left to right. Any bin that crosses above T2 signifies the existence of a peak. Scanning continues to the right until one bin or more crosses below T2. However, if the bin(s) cross below T2 for less than a hundredth of the histogram range, they are ignored, and scanning continues in search of a peak(s) that crosses under T2 for more than a hundredth of the histogram range. Scanning goes on over the remainder of the range to identify additional peaks. Additional peaks within a fiftieth of the range of the populated part of a range from a previous peak are ignored.

Note:

If the number of bins is set too high, a histogram may have many small gaps. This increases sigma and thereby T2, and in extreme cases can prevent determination of a peak, even if one appears visible to the eye.

Appendix B: Histogram Parameters

Example:

Two peaks have been identified below. The one with the highest population is peak #1.

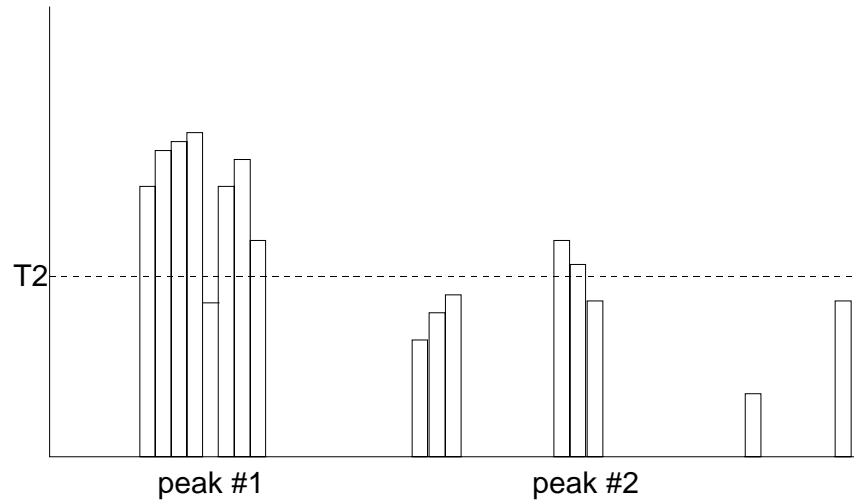

range

Range

Definition

Computes the difference between the value of the rightmost and that of the leftmost populated bin.

Description

The rightmost and leftmost populated bins are identified. The difference in value between the two is returned as the **range**.

Example:

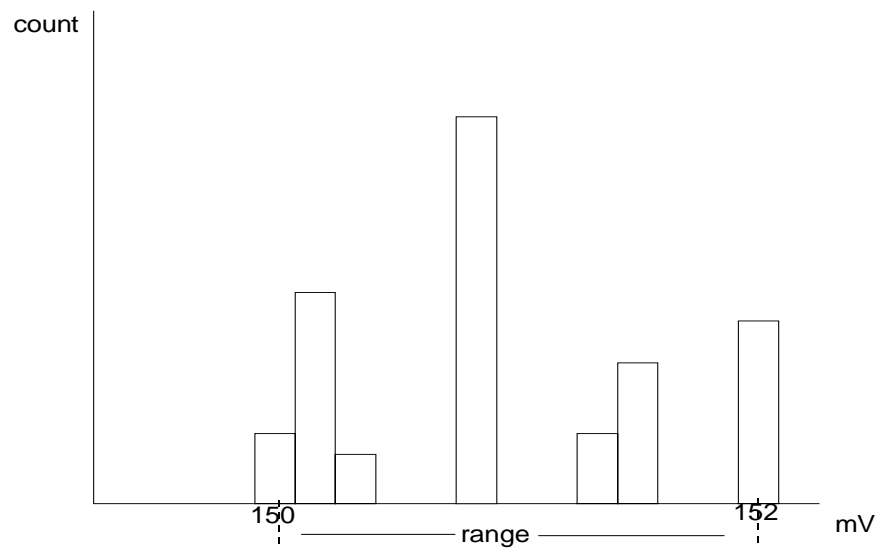

In this example, **range** is 2 mV.

sigma

Definition
Description

Sigma

The standard deviation of the data in a histogram.

sigma is calculated by the formulas:

$$\text{mean} = \frac{\sum_{i=1}^n [\text{bin count}_i * \text{bin value}_i]}{\left(\sum_{i=1}^n \text{bin count}_i\right)}$$

sigma =

$$\sqrt{\frac{\sum_{i=1}^n [\text{bin count}_i * (\text{bin value}_i - \text{mean})^2]}{\left(\sum_{i=1}^n [\text{bin count}_i] - 1\right)}}$$

where **n** is the number of bins in the histogram, bin count is the count or height of a bin and bin value is the center value of the range of parameter values a bin can represent.

Example:

For the histogram:

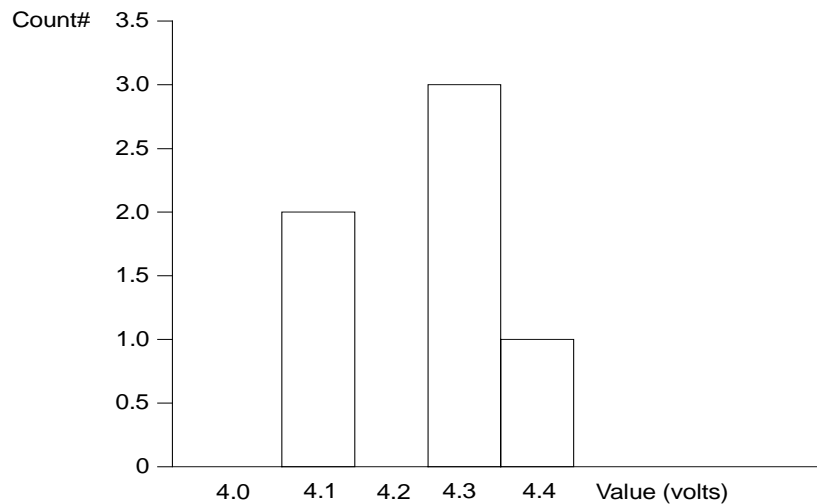

$$\text{mean} = (2 * 4.1 + 3 * 4.3 + 1 * 4.4) / 6 = 4.25$$

$$\text{sigma} = \sqrt{(2 * (4.1 - 4.25)^2 + 3 * (4.3 - 4.25)^2 + 1 * (4.4 - 4.25)^2) / (6 - 1)} = .1225$$

totp

Total Population

Definition

Calculates the total population of a histogram between the parameter cursors.

Description

The count for all populated bins between the parameter cursors is summed.

Example:

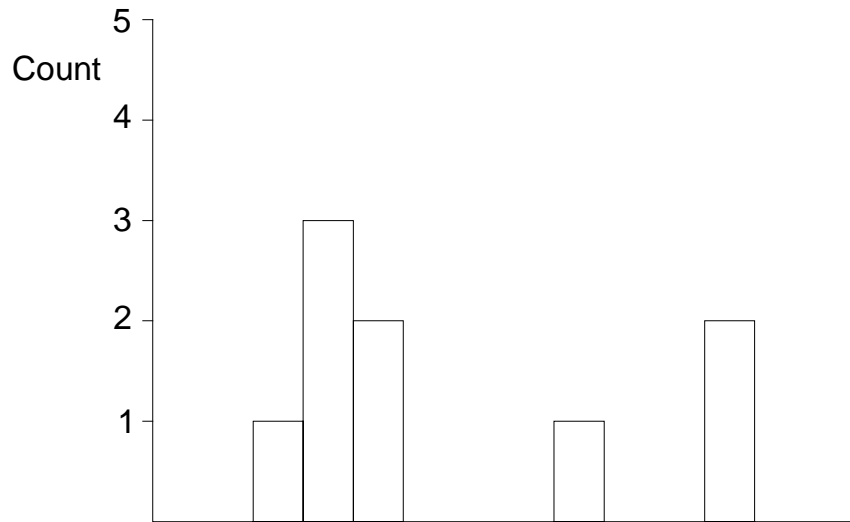

The total population of this histogram is 9.

xapk

X Coordinate of xxth Peak

Definition

Returns the value of the **xx**th peak that is the largest by area in a histogram.

Description

First the peaks in a histogram are determined and ranked in order of total area. (For a discussion on how peaks are identified, see the description for the **pks** parameter.) The center of the **n**th ranked peak (the point where the area to the left is equal to the area to the right), where **n** is selected by the user, is then returned as **xapk**.

Example:

The rightmost peak is the largest, and thus the first-ranked, in area (1). The leftmost peak, although higher, is ranked second by area (2). The lowest peak is also the smallest in area (3).

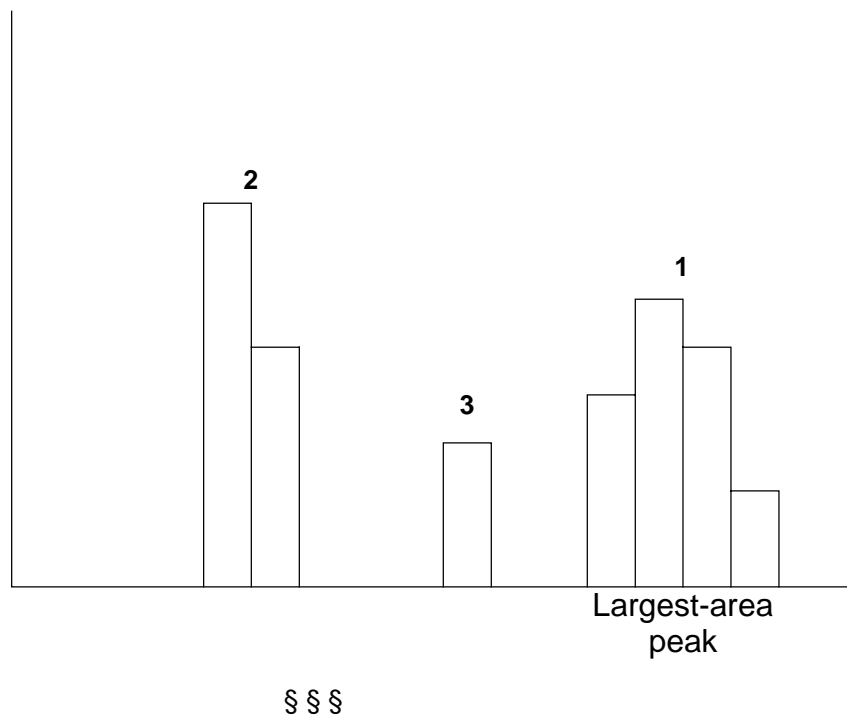

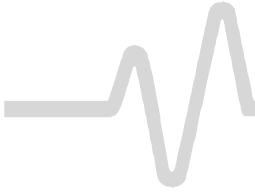

BLANK PAGE

Cursor

Parameter_Custom, PACU
Command/Query

Description

The Parameter_Custom command controls the timing parameters. Only these parameters are described here. However, statistical and other standard parameters are described in the instrument's *Remote Control Manual*.

The measured value of a parameter that was set up with PACU may be read using PAVA.

<param>	definition:	<qualifier> list:
DPLEV	delta period at level (Clock)	<source>,<input_type>,<edge>,<level>
	delta period at level (Data)	<source>,<input_type>,<edge>,<level>,<for_all>,<ref_type>,<freq>
DULEV	duty cycle at level	<source>,<edge>,<level>
EDLEV	delta delay	<source>,<edge>,<level>
PLEV	period at level (Clock)	<source>,<input_type>,<edge>,<level>
	period at level (Data)	<source>,<input_type>,<edge>,<level>,<for_all>,<ref_type>,<freq>
FREQLEV	frequency at level (Clock)	<source>,<input_type>,<edge>,<level>,<for_all>,<ref_type>,<freq>
	frequency at level (Data)	<source>,<input_type>,<edge>,<level>,<for_all>,<ref_type>,<freq>
TIELEV	time interval error at level (Clock or Data)	<source>,<input_type>,<edge>,<level>,<scale>,<for_all>,<ref_type>,<freq>
WIDLEV	width at level	<source>,<edge>,<level>

Where:

<source>: = {C1, C2, C3, C4, TA, TB, TC, TD}

<input_type>: = CLK when Clock mode is to be used
: = DATA when Data mode is to be used

<edge>: = {POS, NEG}

<level>: = 1 to 99 if level is specified in percent (PCT). If PCT is not specified, the level is in the units of the <source> waveform.

<for_all>: = {YES, NO}
<scale>: = {UI, S}
<ref_type>: = {STD, CUST}
CUST <freq>: = 10 to 1e9 Hz
STD <freq>: = {1.5M, 2M, 8M, 34M, 44M, 52M, 139M, 155M}

Command Syntax

PParameter_Custom <line>, <parameter>, <qualifier>,
[<qualifier>, ...]
<line>: = 1 to 5
<parameter>: = {a parameter from the table}
<qualifier>: = Measurement qualifier(s) specific to each.

Note:

CUST1, CUST2, CUST3, CUST4, CUST5 refer to the custom line numbers of the selected parameters.

Query Syntax

PParameter_CUstom? <line>

Response Format

PParameter_CUstom <line>, <parameter>, <qualifier>
[,<qualifier>,...]

Availability

<source>: = {C3, C4} available only on four-channel instruments.

Appendix C: Remote Control Commands

Examples

DPLEV

Command:

1. PACU 1, DPLEV, TA, DATA, POS, 0E-3 V, 0.5 DIV, NO, CUST, 1.125E+8 HZ
2. PACU 1, DPLEV, TA, CLK, POS, 0E-3 V, 0.5 DIV

Query/Response:

PACU? 1 returns:

- 1: PACU 1, DPLEV, TA, DATA, POS, 0E-3 V, 0.5 DIV, NO, CUST, 1.125E+8 HZ
- 2: PACU 1, DPLEV, TA, CLK, POS, 0E-3 V, 0.5 DIV

PAVA? CUST1 returns:

C2: PAVA CUST1, 1E-9 S, OK

Examples

TIELEV

Command:

PACU 1, TIELEV, TA, DATA, POS, 1 PCT, 0.5 DIV, UI, YES, STD, 34M

Query/Response:

PACU? 1 returns:

PACU 1, TIELEV, TA, DATA, POS, 1 PCT, 0.5 DIV, UI, YES, STD, 34M

Related Commands

- Parameter_Delete
- Parameter_Value?
- Parameter_Statistics
- Parameter_Clr
- Pass_Fail_xxx



Function

Define, DEF

Command/Query

Description

The Define command controls JitterPro and JTA functions. This command is also used to control all functions in the standard instruments, as well as the statistical functions common to JitterPro, JTA, and WP03 options. (See the *Remote Control Manual*.)

Command Syntax

<function> : DEFine EQN, "<equation>," [<attribute_name>,<value>, ...]

Note:

Function attributes are grouped in pairs. The first in the pair, <attribute_name>, names the variable to be modified, while the second one <value>, gives the new value to be assigned. Pairs can be given in any order.

Query Syntax

<function>: DEFine?

Response Format

<function>: DEFine EQN, "<equation>," [<attribute_name>,<value>, ...]

Availability

<sourceN>: C3 and C4 — available only on four-channel instruments.

Related Commands

Find_Ctr_Range, Function_Reset, Inr?

Appendix C: Remote Control Commands

Jitter (Cycle-to-Cycle) <function>: Def Eqn, "JitterCC (<source>)", Slope, <slope>, Level, <level>, Input_Type, <input_type>, [For_All, <for_all>, Freq_Std, <std_freq> (or Freq, <cust_freq>)]

Where:

<source>: = {C1, C2, C3,C4,TA, TB, TC, TD}
<function>: = {TA, TB, TC, TD}
<slope>: = {POS, NEG}
<level>: = 1 to 99 if level is specified in percent (PCT), or level in the units of the <source> waveform
<input_type>: = {CLK, DATA}
<for_all>: = {YES, NO}
<std_freq>: = {1.5M, 2M, 8M, 34M, 44M, 52M, 139M, 155M}
<cust_freq>: = 1 to 1e+9 HZ

Note: Scaling of the JitterTrack™ function Find Jitter Range can be executed using the Find_Ctr_Range (FCR) command. Example: TA:FCR scales JitterTrack on Trace A.

Command Examples

Clock Input Type: TA:DEF EQN, "JITTERCC(C1)," SLOPE, POS, LEVEL, 0E-3, HYST, 0.5 DIV, TYPE, CLK

Data Input Type, with custom frequency: TA:DEF EQN, "JITTERCC(C1)," SLOPE, POS, LEVEL, OE-3, 0.5 DIV, TYPE, DATA, FOR_ALL, YES, FREQ, 1 .125e+08 HZ

Data Input Type, with standard frequency: TA:DEF EQN, "JITTERCC(C1)," SLOPE, POS, LEVEL, OE-3, 0.5, TYPE, DATA, FOR_ALL, YES, FREQ_STD, 1.5M

Query/Response Examples TA:DEF? returns a string similar to the command examples.



Jitter (Duty Cycle–)

<function>: Def Eqn, "Jitterduty (<source>)," Slope, <slope>,
Level, <level>

Where:

<source>: = {C1, C2, C3,C4,TA, TB, TC, TD}

<function>: = {TA, TB, TC, TD}

<slope>: = {POS, NEG}

<level>: = 1 to 99 if level is specified in percent (PCT), or level in
the units of the <source> waveform

Note:

Scaling of the JitterTrack™ function Find Jitter Range can be
executed using the Find_Ctr_Range (FCR) command.
Example: TA:FCR scales JitterTrack on Trace A.

Command Examples

Absolute level: TA:DEF EQN, "JITTERDUTY(C2)," SLOPE, POS, LEVEL,
213.9E-3, 0.5

Relative level: TA:DEF EQN, "JITTERDUTY (C2)," SLOPE, POS, LEVEL, 42
PCT, 0.5

Query/Response Examples TA:DEF? returns:

Absolute level: TA:DEF EQN, "JITTERDUTY (C2)," SLOPE, POS, LEVEL,
213.9E-3 V, 0.5

Relative level: TA:DEF EQN, "JITTERDUTY (C2)," SLOPE, POS, LEVEL, 42
PCT, 0.5

Appendix C: Remote Control Commands

Jitter (Interval Error–) <FUNCTION>: DEF EQN, "JITTERIE (<SOURCE>)," SLOPE, <SLOPE>, LEVEL, <LEVEL>, VUNIT, <VUNIT>, INPUT_TYPE, <INPUT_TYPE>, FOR_ALL, <FOR_ALL>, FREQ_STD, <STD_FREQ> (OR FREQ, <CUST_FREQ>)

Where:

- <source>: = {C1, C2, C3, C4, TA, TB, TC, TD}
- <function>: = {TA, TB, TC, TD}
- <slope>: = {POS, NEG}
- <level>: = 1 to 99 if level is specified in percent (PCT), or level in the units of the <source> waveform
- <vunit>: = {UI, S}
- <input_type>: = {CLK, DATA}
- <std_freq>: = {1.5M, 2M, 8M, 34M, 44M, 2M, 139M, 155M}
- <cust_freq>: = 10 to 1e9 Hz.

Note: Scaling of the *JitterTrack*[™] function Find Jitter Range can be executed using the Find_Ctr_Range (FCR) command. Example. TA:FCR scales *JitterTrack* on Trace A.

Command Examples

Clock Input Type, in UI, and custom frequency: TA:DEF EQN, "JITTERIE(C2)," SLOPE, POS, LEVEL, -6E-3V, 0.5, VERT_UNIT, UI, TYPE, CLK, FREQ_GLOBAL, YES, FREQ, 1.99987e+06 HZ

Clock Input Type, in S, with custom frequency: TA:DEF EQN, "JITTERIE(C2)," SLOPE, POS, LEVEL, -6E-3V, 0.5, VERT_UNIT, S, TYPE, CLK, FREQ_GLOBAL, YES, FREQ, 1.99987e+06

Data Input Type, in S, with standard frequency: TA:DEF EQN, "JITTERIE(C2)," SLOPE, POS, LEVEL, -6E-3V, 0.5, VERT_UNIT, S, TYPE, DATA, FREQ_GLOBAL, YES, FREQ_STD, 2M

Query/Response Examples TA:DEF? returns a string similar to the command examples.



Jitter (Period-)

<function>: Def Eqn, "Jitterp (<source>)," Slope, <slope>, Level, <level>, Input_Type, <input_type>,[For_All, <for_all>, Freq_Std, <std_freq> (or Freq, <cust_freq>)]

Where:

<source>: = {C1, C2, C3, C4, TA, TB, TC, TD}
<function>: = {TA, TB, TC, TD}
<slope>: = {POS, NEG}
<level>: = 1 to 99 if level is specified in percent (PCT), or level in the units of the <source> waveform
<input_type>: = {CLK, DATA}
<for_all>: = {YES, NO}
<std_freq>: = {1.5M, 2M, 8M, 34M, 44M, 52M, 139M, 155M}
<cust_freq>: = 1 to 1e+9 HZ

Note:

Scaling of the *JitterTrack*[™] function Find Jitter Range can be executed using the Find_Ctr_Range (FCR) command. Example. TA:FCR scales *JitterTrack* on Trace A.

Command Examples

Clock Input Type: TA:DEF EQN, "JITTERP(C1)," SLOPE, POS, LEVEL, 0E-3, 0.5 DIV, TYPE, CLK

Data Input Type, with custom frequency: TA:DEF EQN, "JITTERP(C1)," SLOPE, POS, LEVEL, 0E-3, 0.5 DIV, TYPE, DATA, FOR_ALL, YES, FREQ, 1.125e+08 HZ

Data Input Type, with standard frequency: TA:DEF EQN, "JITTERP(C1)," SLOPE, POS, LEVEL, 0E-3, 0.5, TYPE, DATA, FOR_ALL, YES, FREQ_STD, 1.5M

Query/Response Examples TA: DEF? returns a string similar to the command examples.

Appendix C: Remote Control Commands

Jitter (Frequency–)

<function>: Def Eqn, "Jitterfreq (<source>)," Slope, <slope>,
Level, <level>, Input_Type, <input_type>, [For_All, <for_all>,
Freq_Std, <std_freq> (or Freq, <cust_freq>)]

Where:

<source>: = {C1, C2, C3, C4, TA, TB, TC, TD}
<function>: = {TA, TB, TC, TD}
<slope>: = {POS, NEG}
<level>: = 1 to 99 if level is specified in percent (PCT), or level in
the units of the <source> waveform
<input_type>: = {CLK, DATA}
<for_all>: = {YES, NO}
<std_freq>: = {1.5M, 2M, 8M, 34M, 44M, 52M, 139M, 155M}
<cust_freq>: = 1 to 1e+9 HZ

Note:

Scaling of the *JitterTrack*[™] function Find Jitter Range can be
executed using the Find_Ctr_Range (FCR) command. Example.
TA:FCR scales *JitterTrack* on Trace A.

Command Examples

Clock Input Type: TA:DEF EQN, "JITTERFREQ(C1)," SLOPE, POS, LEVEL, 0E-3,
0.5 DIV, TYPE, CLK

Data Input Type,
with custom frequency: TA:DEF EQN, "JITTERFREQ(C1)," SLOPE, POS, LEVEL, 0E-,
0.5 DIV, TYPE, DATA, FOR_ALL, YES, FREQ, 1.125e+08 HZ

Data Input Type,
with standard frequency: TA:DEF EQN, "JITTERFREQ(C1)," SLOPE, POS, LEVEL, 0E-3, 0.5,
TYPE, DATA, FOR_ALL, YES, FREQ_STD, 1.5M

Query/Response Examples TA:DEF? returns a string similar to the command examples

Jitter (Width-)

<function>: Def Eqn, "Jitterw (<source>)," Slope, <slope>, Level, <level>

Where:

<source>: = {C1, C2, C3, C4, TA, TB, TC, TD}

<function>: = {TA, TB, TC, TD}

<slope>: = {POS, NEG}

<level>: = 1 to 99 if level is specified in percent (PCT), or level in the units of the <source> waveform

Note:

Scaling of the *JitterTrack*TM function Find Jitter Range can be executed using the Find_Ctr_Range (FCR) command. Example. TA:FCR scales *JitterTrack* on Trace A.

Command Examples

Absolute level: TA:DEF EQN, "JITTERW(C2)," SLOPE, POS, LEVEL, 213.9E-3, 0.5

Relative level: TA:DEF EQN, "JITTERW (C2)," SLOPE, POS, LEVEL, 42 PCT, 0.5

Query/Response Examples TA:DEF? returns:

Absolute level: TA:DEF EQN, "JITTERW (C2)," SLOPE, POS, LEVEL, 213.9E-3 V, 0.5

Relative level: TA:DEF EQN, "JITTERW (C2)," SLOPE, POS, LEVEL, 42 PCT, 0.5

Appendix C: Remote Control Commands

Perhist<function> : DEFine EQN, "Perhist(<source>)," SI_Dir,<dir_value>, SI_Center, <center_value>, SI_Width, <width_value>

Where:

- <source>: = {C1, C2, C3, C4, TA, TB, TC, TD}
- <function>: = {TA, TB, TC, TD}
- <dir_value>: = {V, H}
- <center_value>: = -4.00 to 4.00 DIV
- <width_value>: = 1 to 255 bins for horizontal slices, or 1 to 999 pixels for vertical slices.

Command Examples

Horizontal Slice: TA:DEF EQN, "PERHIST(C2)," SL_DIR, H, SL_CENTER, -0.62 DIV, SL_WIDTH, 34

Vertical Slice: TA:DEF EQN, "PERHIST(C2)," SL_DIR, V, SL_CENTER, -0.62 DIV, SL_WIDTH, 34

Query/Response Examples

Horizontal Slice: TA:DEF EQN, "PERHIST(C2)," SL_DIR, H, SL_CENTER, -0.62 DIV, SL_WIDTH, 34

Vertical Slice: TA:DEF EQN, "PERHIST(C2)," SL_DIR, V, SL_CENTER, -0.62 DIV, SL_WIDTH, 34

Pertrace (Average) <function>: Def Eqn, "Pertrace(<source>)," Ptr_Type, AVG

Where:

- <source>: = {C1, C2, C3, C4, TA, TB, TC, TD}
- <function>: = {TA, TB, TC, TD}
- <sigma_value>: = 0.5 to 10.0
- <pop_value>: = 0.5 to 100.0 PCT

Command Example TD:DEF EQN, "PERTRACE(C2)," PTR_TYPE, AVG

Query/Response Example TA:DEF? returns:
TD:DEF EQN, "PERTRACE(C2)," PTR_TYPE, AVG

Appendix C: Remote Control Commands

Pertrace (Sigma)

<function>: DEF EQN, "PERTRACE(<source>)," PTR_TYPE,
SIGMA, IGMA_FACT,<sigma_value>

Where:

<source>: = {C1, C2, C3, C4, TA, TB, TC, TD}

<function>:= {TA, TB, TC, TD}

<sigma_value>: = 0.5 to 10.0

<pop_value>: = 0.5 to 100.0 PCT

Command Example

TD:DEF EQN,"PERTRACE(C2)",PTR_TYPE,SIGMA,SIGMA_FACT,1.5

Query/Response Example **TA:DEF?** returns:

TD:DEF EQN,"PERTRACE(C2)",PTR_TYPE,SIGMA,SIGMA_FACT,1.5

Pertrace (Range)

<function>: Def Eqn, "Pertrace (<source>)." Ptr_Type, Range, Range_Pop, <pop_value>

Where:

<source>: = {C1, C2, C3, C4, TA, TB, TC, TD}

<function>: = {TA, TB, TC, TD}

<sigma_value>: = 0.5 to 10.0

<pop_value>: = 0.5 to 100.0 PCT

Command Example

TD: DEF EQN, "PERTRACE(C2)," PTR_TYPE, RANGE, Pertrace

Query/Response Example

TA:DEF? returns:

TD: DEF EQN, "PERTRACE(C2)," PTR_TYPE, RANGE, RANGE_POP, 99.5 PCT

§ § §

Architecture & Specifications

INSTRUMENT ARCHITECTURE OVERVIEW

Processors

The Jitter and Timing Analyzer's central processing unit (CPU), a PowerPC™ microprocessor, performs the oscilloscope's computations, and controls its operation. A range of peripheral interfaces allow you to control remotely, store waveforms and other data, and make hard copies. A support processor constantly monitors the front panel controls. The Jitter and Timing Analyzer transfers data to display memory for direct waveform display, or stores it in reference memories for fast data processing.

ADCs

The instrument's ADC architecture is designed to give excellent amplitude and phase correlation, maximum analog-to-digital conversion performance, large record lengths, and superior time resolution.

Memories

Jitter and Timing Analyzer acquisition memories simplify signal acquisition by producing waveform records that allow detailed analysis over large time intervals. There are four memories for temporary storage, and four more for waveform zooming and processing.

RIS

The Jitter and Timing Analyzer captures and stores repetitive signals at a maximum Random Interleaved Sampling (RIS) rate of 50 GS/s. This advanced digitizing technique enables measurement of repetitive signals with an effective sampling interval of 20 ps, and a resolution of up to 5 ps.

Trigger System

You can control Jitter and Timing Analyzer triggering to a highly specialized degree in accordance with waveform characteristics and chosen trigger conditions. The trigger source can be any of the input channels, line (synchronized to scope's main input supply) or external. The coupling is selected from AC, LF REJect, HF REJect, HF, and DC; the slope from positive and negative. The Jitter and Timing Analyzer SMART Trigger offers a wide range of sophisticated trigger modes matched to special trigger conditions and sets of conditions.

Automatic Calibration

The Jitter and Timing Analyzer's automatic calibration ensures the overall vertical accuracy. Vertical gain and offset calibration, and horizontal (time) resolution take place each time you change the volts per division setting. Periodic and temperature dependent auto-calibration ensures long-term stability at the current setting.

Display System

You control the display's interactive, user-friendly interface using push buttons and knobs. Display as many as eight different waveforms at once on eight separate grids. The parameters controlling signal capture are simultaneously reported. The Jitter and Timing Analyzer displays internal status and measurement results, as

Jitter and Timing Analyzer

well as operational, measurement, and waveform analysis menus.

The 10.4-inch color flat panel TFT LCD screen displays waveforms and data by means of advanced color management. Overlap mixing and contrast enhancement functions ensure that overlapping waveforms remain distinct at all times. Preset and personal color schemes are available.

The Analog Persistence function offers display attributes of an analog instrument with all the advantages of digital technology. The Full Screen function expands waveform grids to fill the entire screen.

A hard copy of the screen can be easily produced by pressing the front panel PRINT SCREEN button.

Interface and Panel Setups

Although the Jitter and Timing Analyzer is a truly digital instrument, the front panel layout and controls are similar to those of an analog oscilloscope. Rapid response and instant representation of waveforms on the high resolution screen add to this similarity. Four front panel setups can be stored internally, and recalled directly or by remote control, thus ensuring rapid front panel configuration. When power is switched off, the front panel settings are automatically stored for recall when the scope is next powered on.

Remote Control

The Jitter and Timing Analyzer has also been designed for remote control operation in automated testing and computer aided measurement applications. You control the entire measurement process — cursor and pulse-parameter settings, dynamic modification of front panel settings, and display organization — through the rear panel industry standard GPIB (IEEE-488), standard RS-232-C, and optional LAN (Ethernet) ports. See Chapter 12, “Use the WavePro DSO with a PC,” in this manual; see also the *Remote Control Manual*.

Architecture & Specifications

Hi Z, 50 Ohm Amplifiers + Attenuators

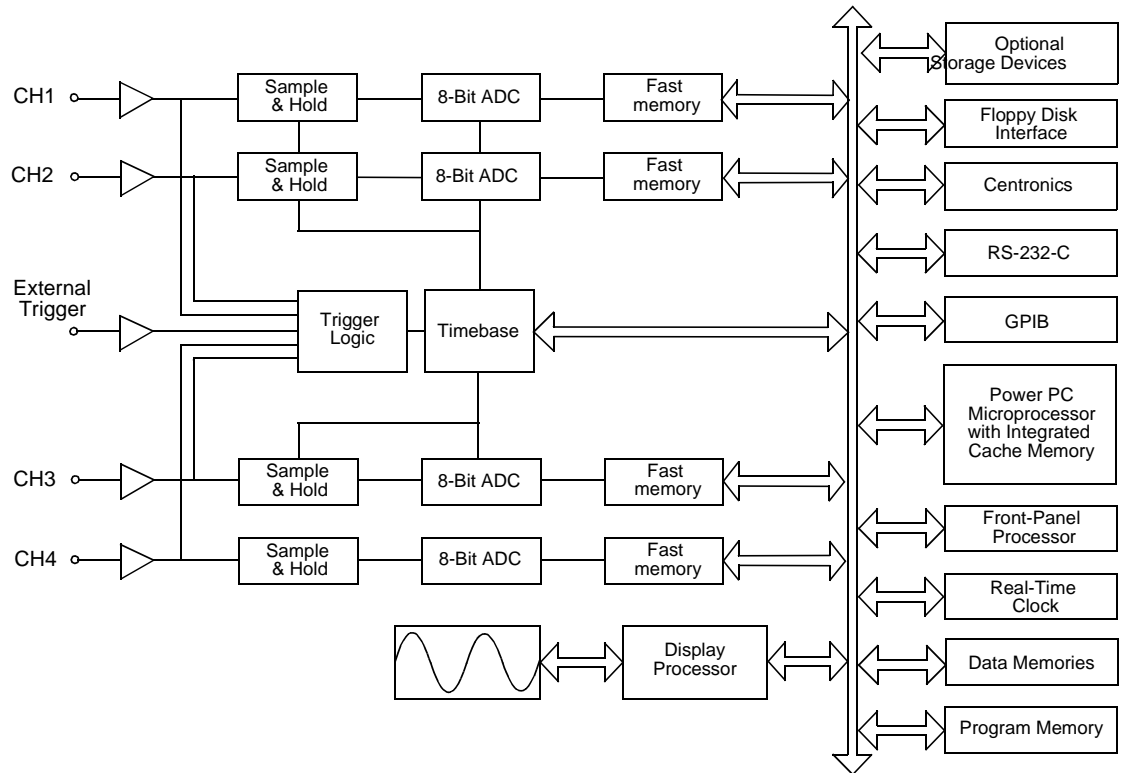

Jitter and Timing Analyzer Models

Jitter and Timing Analyzer

SPECIFICATIONS

Models

Jitter and Timing Analyzer J-260/J-250: Four channels

NOTE: Specifications are subject to change without notice.



Vertical System

Bandwidth (–3dB): **J-260:** 2 GHz* @ 50 Ω; **J-250:** 1 GHz @ 50 Ω

Bandwidth Limiter: 20 MHz or 200 MHz.

Input Impedance: 50 Ω ±1.5%; 10 MΩ // 11 pF typical (using PP005 probe)

Input Coupling: 1 MΩ: AC, DC, GND; 50 Ω: DC, GND



Max Input: 50 Ω: 5 V rms; 1 MΩ: 100 V max (peak AC ≤ 5 kHz + DC)

Vertical Resolution: 8 bits; up to 11 bits with enhanced resolution (ERES)

Sensitivity: 50 Ω: 1 mV to 1 V/div fully variable; 1 MΩ: 1 mV to 2 V/div fully variable

DC Accuracy: ±2.0% of full scale +1.5% offset value @ gain > 10 mV

Offset Accuracy: ±(1.5% + 0.5% of full scale + 1 mV)

Offset Range: 50 Ω or 1 MΩ: 1 mV to 4.99 mV/div: ±400 mV

50 Ω: 5 mV to 99 mV/div: ±1 V; 0.1 V to 1 V/div: ±10V

1 MΩ: 5 mV to 100 mV/div: ±1 V; 101 mV to 2 V/div: ±20 V

Isolation – channel to channel: > 250:1 at same V/div settings

Timebase System

Timebases: Main and up to four zoom traces simultaneously

Time/Div Range: 200 ps/div to 1000 s/div

Clock Accuracy: ≤ 3 ppm

Interpolator Resolution: 5 ps

External Clock Frequency: 500 MHz max., 50 Ω, or 1 MΩ impedance

Roll Mode – Operating Range: time/div 500 ms to 1000 s/div or sample rate < 100 kS/s max.

External Reference (Optional): 10 MHz timebase reference clock available with input on rear panel

* at sample speeds > 4 GS/s and @ 10 mV or greater volts/division settings

Architecture & Specifications

External Timebase Clock: 500 MHz maximum external sample clock input on front panel EXT BNC

Acquisition System

	Single Shot Sample Rate	
	J-260	J-250
1 Channel Max.	16 GS/s	16 GS/s
2 Channels Max.	8 GS/s	8 GS/s
3–4 Channels Max.	4 GS/s	4 GS/s

	Max. Acquisition Points/ Channel 1 Ch / 2 Ch / 3–4 Ch	
	J-260	J-250
L Memory Option	16M/8M/4M	16M/8M/4M
VL Memory Option	32M/16M/8M	32M/16M/8M

Jitter and Timing Analyzer

	Acquisition Modes	
	J-260	J-250
Random Interleaved Sampling (RIS)	50 GS/s for repetitive signals: 200 ps/div to 1 μ s/div	
Single Shot	For transient and repetitive signals: 200 ps/div to 1000 s/div	
Sequence	2 to 4000 segments	
Max. Segments/Memory	4000/8M 1000/1M 250/250K	
Intersegment Time	Typically 30 μ s	

Acquisition Processing: Averaging: summed averaging to 10^3 sweeps (standard)
 continuous averaging up to 10^6 sweeps; continuous averaging with weighting
 ranges from 1:1 to 1:1023

Enhanced Resolution (ERES): from 8.5 to 11 bits vertical resolution

Envelope (Extrema): Envelope, floor, roof for up to 10^6 sweeps

Triggering System

Modes: NORMAL, AUTO, SINGLE and STOP

Sources: Any input channel, External, EXT/5, or line; slope, level, and coupling unique to each except line

Slope: Positive, Negative, Window

Coupling Modes: DC, AC, HF, HFREJ, LFREJ

AC Cutoff Frequency: 7.5 Hz typical

HFREJ, LFREJ: 50 kHz typical

Pre-trigger Recording: 0 to 100% of horizontal time scale

Post-trigger Delay: 0 to 10000 divisions

Holdoff by Time or Events: Up to 20 s or from 1 to 99999999 events

Internal Trigger Range: ± 5 div

Maximum Trigger Frequency: Triggers up to maximum bandwidth (HF), 1 GHz (AC, DC)



External Trigger Input Range: ± 0.5 V (± 2.5 V with Ext/5 selected)

Max. External Input @ 50 Ω : ± 5 V DC or 5 V rms

Max. External Input @ 1 M Ω : 100 V max. (DC + peak AC < 5 kHz)

Architecture & Specifications

SMART Triggers (all models)

Edge/Slope/Window/Line: Triggers when the signal meets the slope and level condition. Window Trigger allows you to define a window region whose boundaries extend above and below the selected trigger level. A trigger event occurs when the signal leaves this window region in either direction and passes into the upper or lower region. The next trigger will occur if the signal again passes into the window region. For a trigger to occur, the time that the signal spends within the window must be at least 0.5 ns.

State or Edge qualified: Triggers on any input source only if a defined state or edge occurred on another input source. Delay between sources is selectable by time or events.

Dropout: Triggers if the input signal drops out for longer than a selected time-out between 2 ns and 20 s.

Pattern: Logic combination of 5 inputs (4 channels and external trigger input); Each source can be high, low, or don't care. Trigger at the start or end of the pattern.

SMART Triggers with Exclusion Technology

Signal or Pattern Width: Triggers on glitches or on pulse widths selectable from 600 ps to 20 s or on intermittent faults.

Signal or Pattern Interval: Triggers on intervals selectable between 2 ns and 20 s.

Slew Rate: Triggers on edge rates; select limits for dV, dt, and slope.

Runt: Positive or negative runts are defined by two voltage limits and two time limits selectable between 600 ps and 20 ns.

AutoSetup

Automatically sets timebase, trigger, and sensitivity to display a wide range of repetitive signals.

Vertical Find: Automatically sets the vertical sensitivity and offset for the selected channels to display a waveform with maximum dynamic range.

Probes

Model PP005: 10:1, 10 M Ω with auto-detect; one probe per channel

ProBus Probe System: Automatically detects and supports a wide variety of differential amplifiers; active, high-voltage, current, and differential probes

Scale Factors: Up to 12 automatically or manually selected

Color Waveform Display

Type: Color 10.4-inch flat panel TFT LCD

Resolution: 640 x 480 resolution

Screen Saver: Display blanks after 10 minutes when this feature is enabled

Real Time Clock: Date, hours, minutes, and seconds displayed with waveform

Number of Traces: Maximum of eight traces; simultaneously displays channel, zoom, memory, and math traces

Grid Styles: Single, Dual, Quad, Octal, XY, Single+XY, Dual+XY; Full Screen gives enlarged view of each

Jitter and Timing Analyzer

style

Intensity Controls: Separate intensity control for grids and waveforms

Waveform Display Styles: Sample dots joined or dots only — regular or bold sample point highlighting

Trace Overlap Display: Select opaque or transparent mode with automatic waveform overlap management

Analog Persistence Display

Analog Persistence and Color Graded Persistence: Variable saturation levels; stores each trace's persistence data in memory

Trace Selection: Activate Analog Persistence on a selected trace, the top 2 traces, or all traces

Persistence Aging Time: From 500 ms to infinity

Trace Display: Opaque or transparent overlap

Sweeps displayed: All accumulated or all accumulated with last trace highlighted

Zoom Expansion Traces

Display up to four zoom traces

Vertical Zoom: Up to 5x expansion, 50x with averaging

Horizontal Zoom: Expand to 2 pts/div, magnify to 50 000x

Auto Scroll: Automatically scans and displays any zoom or math trace

Rapid Signal Processing

Processor: PowerPC

Processing Memory: \geq 256 Mbytes

Real-time Clock: dates, hours, minutes, seconds, and time stamp trigger time to 1 ns resolution

Pass/Fail: Test any five parameters against selectable thresholds. Limit testing is performed using masks created on the scope or on a PC. Set up a pass or fail condition to initiate actions such as hard copy output, save waveform to memory, GPIB SRQ, or pulse out.

Internal Waveform Memory

Waveform: M1, M2, M3, M4 (Store full-length waveforms with 16 bits/data point.)

Zoom and Math: A, B, C, D with chained trace capability

Setup Storage

Front Panel and Instrument Status: Four non-volatile memories and floppy drive are standard; hard drive and memory card are optional

CustomDSO: Customize and access scope settings with up to 6 CustomDSO files stored in internal non-volatile virtual disk (VDisk)

Architecture & Specifications

Interface

Remote Control: Full control of all front panel controls and internal functions through GPIB, Ethernet, or RS-232-C

RS-232-C: Asynchronous transfer rate of up to 115.2 kbaud*

GPIB Port: full control through IEEE-488.2; configurable as talker/listener for computer control and data transfer *

Ethernet (optional): 10BaseT Ethernet interface *

Floppy Drive: Internal, DOS format, 3.5 inch, high density

PC Card Slot: Supports memory and hard drive cards

External Monitor Port: 15-pin D-Type VGA compatible*

Centronics Port: Parallel printer interface*

Internal graphics printer (optional): provides hardcopy output in < 10 s. The part number is GPR10 for ten rolls.

Pass/Fail and Trigger Output: Front panel Cal BNC output provides choice of Cal Signal, Pass/Fail Condition, Trigger Ready, or Trigger Out signals

Outputs

Calibrator Signal: 500 Hz to 2 MHz square wave or 25 ns pulse; 0.05 to +1.0 V into 1 M Ω output from front panel BNC connector

Control Signals: Trigger Ready, Trigger Out, or Pass/Fail status

Math Tools

Simultaneously perform up to four math processing functions; traces can be chained together to perform math on math. Standard functions: add, subtract, multiply, divide, negate, identity, summation, summed averaging to one million sweeps, continuous averaging, ERES low-pass digital filters for 11-bit vertical resolution, FFT of 25 Mpoint waveforms, Extrema for displaying envelope roof and floor, physical units, rescale (with units), sin x/x, resample (deskew), integration, derivative, log and exponential functions, (base e and base 10), square, square root, absolute value, histograms of up to two billion events, FFT averaging, reciprocal (invert), digital filtering (low pass, high pass, band pass, band stop, raised cosine, raised root cosine, Gaussian, custom; plus data log when using the trend function.

* To conform to CE requirements (EMC Directive 89/336/EEC), use properly shielded cables.

Jitter and Timing Analyzer

Measure Tools

Cursor Measurements:

- **Relative Time:** Two arrow cursors measure time and voltage differences relative to each other with a resolution of $\pm 0.05\%$ full scale.
- **Relative Amplitude (Voltage):** Two horizontal bars measure voltage differences at $\pm 0.2\%$ fs resolution.
- **Absolute Time:** Cross-hair marker measures time relative to trigger and voltage with respect to ground.
- **Absolute Amplitude (Voltage):** A horizontal reference line cursor measures voltage with respect to ground.

Automated Measurements: Display any five parameters together with their average, high, low and standard deviations.

Pass/Fail: Test any five parameters against selectable thresholds. Limit testing is performed using masks created on the scope or on a PC. Setup a pass or fail condition to initiate actions such as hardcopy output, save waveform to memory, GPIB SRQ, or pulse out.

Jitter Measurements

Jitter Noise Floor: 2 ps rms @ 50 MHz

Jitter Accuracy: 1 ps rms with 3 sigma confidence level

Architecture & Specifications



General

Auto Calibration: Ensures specified DC and timing accuracy is maintained for 1 year minimum

Auto Calibration Time: < 500 ms

Power Requirements: Max. power consumption: < 350 VA

Voltage	Frequency
90 to 132 V AC	45 to 440 HZ
180 to 250 V AC	45 to 66 Hz

Battery Backup: Front panel settings retained for two years minimum

Dimensions (HWD): 264 mm x 397 mm x 453 mm (10.4 in. x 15.6 in. x 17.8 in.); height measurement excludes foot pads

Weight: 14 kg (31 lbs) with internal printer

Shipping Weight: 22.2 kg (49 lbs)

Warranty and Calibration: Three years; calibration recommended yearly

Environmental and Safety

Operating Conditions:

Temperature: 5 to 45 °C

Humidity: 75% max. RH (non-condensing) up to 35 °C
Derates to 50% max. RH at 45 °C

Altitude: 3000 m max. up to 25 °C
Derates to 2000 m max. at 45 °C

Jitter and Timing Analyzer

Certifications: CE, UL and cUL

CE Declaration of Conformity: The oscilloscope meets requirements of the EMC Directive 89/336/EEC for Electromagnetic Compatibility and Low Voltage Directive 73/23/EEC for Product Safety.

EMC Directive:	EN 61326-1:1997 +A1:1998	
	EMC requirements for electrical equipment for measurement, control, and laboratory use.	
Electromagnetic Emissions:	EN55022:1998, Class A	Radiated and conducted emissions
	EN 61000-3-2:1995+A1:1998+A2:1998	Harmonic Current Emissions
	EN 61000-3-3:1995	Voltage Fluctuations and Flickers

Warning: This is a Class A product. In a domestic environment this product may cause radio interference, in which case the user may be required to take appropriate measures.

Electromagnetic Immunity:	EN 61000-4-2:1995 +A1:1998*	Electrostatic Discharge
	EN 61000-4-3:1996 +A1:1998*	RF Radiated Electromagnetic Field
	EN 61000-4-4:1995*	Electrical Fast Transient/Burst
	EN 61000-4-5:1995*	Surges
	EN 61000-4-6:1996*	RF Conducted Electromagnetic Field
	EN 61000-4-11:1994 [†]	Mains Dips and Interruptions

* Meets Performance Criteria "B" limits – during the disturbance, product undergoes a temporary degradation or loss of function of performance which is self recoverable.

† Meets Performance Criteria "C" limits – during the disturbance, product undergoes a temporary degradation or loss of function of performance which requires operator intervention or system reset.

Architecture & Specifications

Low Voltage Directive:	EN 61010-1:1993 +A2:1995 Safety requirements for electrical equipment for measurement, control, and laboratory use. The oscilloscope has been qualified to the following EN 61010-1 category: 300 V Installation (Overvoltage) Category II Pollution Degree 2 Protection Class I
UL and cUL Certifications:	UL Standard: UL 3111-1 Canadian Standard: CSA-C22.2 No. 1010.1-92

Supported Printers:

B/W:	LaserJet, DeskJet, Epson
Color:	DeskJet 550C, Epson Stylus, Canon 200/600/800 series An optional internal, high-speed graphics printer is also available for screen dumps; stripchart output formats capable of up to 200 cm/div
Hard Copy Formats:	TIFF b/w, TIFF color, BMP color, and BMP compressed

§ § §

Jitter and Timing Analyzer

BLANK PAGE

A

Acquisition
 multiple superimposed,
 analyzed using
 Persistence Histogram,
 4-2
 multiple sweeps, analyzed
 using Persistence Trace,
 5-2
 of signal, 2-5, 2-6
 single/continuous, 2-5
 Acquisition sequence
 for Histograms and Trends,
 A-1
 Acquisitions, 3-3, 3-4, 4-2, 5-2,
 A-1, A-2
 amplitude
 levels expressed as a
 percentage of, 3-7
 Analog Persistence™, 4-3, 5-3
 Artifacts, 5-3
 average, 5-1, 5-2, 5-3, 5-4, C-12
 avg histogram parameter, B-1

B

Bins, 4-2, 4-4, 7-2, 7-4, 7-5, 7-6,
 7-7, 7-10, A-2, A-4, B-1, B-2,
 B-3, B-6, B-7, B-8, B-9, B-10,
 B-11, B-12, B-13, B-14, B-16,
 B-17, B-18, B-19
 Bit map, 1-2
 Buffer, A-1

C

Cable deskew, 2-7
 Category, 6-10
 Category menu, 6-1, 6-3, 7-8
 CCTM, 1-2
 measurements, 1-4
 wizard, 2-9
 Center menu
 Histogram, 7-9
 Persistence Histogram, 4-3,
 4-4, 4-5

Trend, 8-4
 CHANGE PARAM menus, 6-3,
 6-10, 7-8
 CHANGE PARAMETERS menu,
 6-1, 6-3, 6-10
 classify into menu, 7-6
 CLEAR SWEEPS button, 7-9
 Clock, 2-3, 3-1, 3-6
 Clock Mode, 3-1, 6-4, 6-8
 Clock signal, 4-2
 Color-Graded Persistence, 4-3,
 5-3
 bins, B-11
 population, B-12
 Crossover point, 4-2
 Cumulative jitter, 4-2
 Cumulative sampling, 3-3
 Cursors, 4-3, 7-10, B-11
 CURSORS/MEASURE button,
 6-1, 7-10
 Custom, 3-8, 6-1, 8-2
 cut menu, 4-3, 5-3
 Cycles, 1-2, 7-3
 Cycle-to-Cycle
 Clock, 3-9
 Data, 3-10
 Histogram, 4-2
 JitterTrack, 3-1 – 3-18, 6-2

D

Data, 3-1, 3-5
 Data Mode, 3-5, 3-10, 3-13, 3-15,
 3-18, 6-4, 6-8
 Data points, A-1
 Datastream, 2-3
 DEFINE, DEF, Command/Query,
 C-4
 Delta Period
 Timing Parameter, 6-6
 Differential inputs, 2-11
 Displayed Trace Field, 3-9, 7-10
 Duty Cycle
 JitterTrack, 3-3, 3-11, 6-2
 Timing Parameter, 6-7
 duty@lv, 6-2, 6-7, A-3



E

edge@lv, 6-2, 6-6, A-3
Edges, 1-2, 3-1, 3-7, 5-2
 counting them, 6-2, 6-6
Envelope, 5-1, 5-5, 5-6
Events, 3-3, 7-9
 maximum number for
 histograms and trends,
 A-2
 maximum per acquisition per
 parameter, A-3
Evolution in time
 monitoring it using
 JitterTrack, 3-3, 3-4
Eye diagram, 1-1, 4-2

F

FFT (Fast Fourier Transform), 3-4
FIND CENTER AND HEIGHT
 menu, 8-3, 8-4
FIND CENTER AND WIDTH
 menu, 7-4, 7-6, 7-7, 8-2
FIND FREQUENCY, 3-8, 3-10,
 3-15, 3-18, 6-11
FIND JITTER RANGE, 3-6 – 3-8,
 3-11, 3-16
FIND LEVEL, 3-7, 3-12, 3-14,
 3-17, 6-4
for all JTA menu, 3-8, 6-11
For all JTA menu, 6-9
freq@lv, 6-2, 6-5
Frequency, 3-2 – 3-8
 clock, 3-17
 Data, 3-18
 defining it for reference
 clock, 1-1
 JitterTrack, 3-3, 3-18, 6-2
 Timing Parameter, 6-5
frequency menu, 3-8, 6-11
fwhm histogram parameter, B-2
fwhx histogram parameter, B-3

H

hampl histogram parameter, B-4

hbase histogram parameter, B-5
Height menu
 Trend, 8-4
high histogram parameter, B-6
Histogram, 2-16, 4-1
 ▲symbol, 7-9
 binning and measurement
 accuracy, A-4
 bins, 7-2, 7-5, 7-6, 7-7, A-4
 calculation, A-1
 custom line menu, 7-4, 8-2
 Displayed Trace Field, 7-5
 displaying all captured
 events, 7-5
 displaying the bar chart, 7-4
 horizontal per division
 settings, 7-5
 number of parameter
 calculations possible with,
 7-4
 number of parameter events
 captured, A-2
 of segmented waveforms,
 7-9
 of Timing Parameters, 7-2,
 7-3
 overview, 1-2
 parameter buffer, A-1
 peaks, A-3, A-4, B-2, B-3,
 B-4, B-5, B-9, B-14, B-19
 population, B-18
 range, A-2, B-13, B-14, B-16
 scaling, 7-6, 7-7
 segmented waveforms, A-2,
 A-3
 selecting number of bins,
 7-6
 setting optimal number of
 bins, A-5
 setting range, 7-5
 setup, 7-3, 7-6, 7-7
 standard deviation, B-17
 statistical information on, 7-5
 Timing Parameters, 6-2
 use with parameters, 7-1

- using cursors with, 7-10
- vertical scale, 7-5
- vs Persistence Histogram, 4-2
- waveform acquisitions and histograms, A-1
- zoom and positioning, 7-5, 7-9, A-3
- Histogram Parameters, 4-1, 6-1, 6-2, 7-1, 7-8, 7-9, B-1, B-2, B-3, B-4, B-5, B-6, B-7, B-8, B-9, B-10, B-11, B-12, B-13, B-14, B-15, B-16, B-17, B-18, B-19
- hmedian histogram parameter, B-7
- Horizontal
 - Persistence Histogram cut, 4-3, 4-4
- hrms histogram parameter, B-8
- htop histogram parameter, B-9

I

- Interpolation filtering, 2-18
- Interval Error, 3-7
 - Clock, 3-12
 - Data, 3-13
 - Jitter, 2-17
 - JitterTrack, 2-17, 3-1, 3-3, 3-6, 3-9 – 3-18, 6-2
- Interval widths, 4-2

J

- Jitter
 - cumulative on an eye diagram, 4-2
 - visualizing it using Persistence, 5-2
- JitterFFT, 2-5, 2-6
- JITTERPRO, 1-1
 - setup, 1-4
- JitterTrack, 6-2
 - Clock, 3-1
 - Clock or Data?, 3-5
 - Cycle-to-Cycle, 3-8, 3-9
 - Data, 3-1
 - Duty Cycle, 3-11
 - Frequency, 3-17, 3-18

- Interval Error, 3-12, 3-13
 - overview, 1-1
 - Period, 3-14, 3-15
 - reference clock, 3-1
 - setup, 3-6, 3-7, 3-8
 - vs Trend, 3-4
 - Width, 3-16
- JitterWizard, 1-1, 2-1, 2-3, 2-6
- JTA
 - selecting for parameter setup, 6-3

L

- Level, 3-1, 3-7, 6-4
- level is, 6-4
- level is menu, 3-7
- level menu, 3-7, 6-4
- Line selection, 6-1, 6-3, 6-10, 8-2
- low histogram parameter, B-10

M

- MATH SETUP button, 3-6, 4-3, 5-3, 7-3, 8-2
- Math Type menu, 3-6, 4-3, 5-3, 7-3, 8-2, 8-3
- maxp histogram parameter, B-11
- measure menu, 6-1, 6-3
- Measurements
 - using Timing Parameters or Timing Functions, 6-2
- mode histogram parameter, B-12
- mode menu, 6-1, 7-10
- MORE (*parameter*) SETUP menu, 6-3, 6-8
- More Hist Setup menu, 7-5
- MORE JITTER SETUP, 3-6
- Multiple waveforms, 2-17

N

- N-cycle, 1-2, 1-4, 2-13
- Neg/Pos, 2-8
- Noise, 4-2, A-4
 - visualizing it using Persistence, 5-2
- Normalization, 3-5



O

of menu, 3-6
On line menu, 6-3, 6-8

P

p@lv, 4-2, 6-2 – 6-4, 7-3, A-3
Parameter buffer, A-1
Parameter categories, 6-3, 6-8
Parameter lines
 see Line selection, Lines,
 6-1
Parameter modification, by line,
 6-3, 6-8
PARAMETER SETUP menu, 7-6,
 7-7, 8-4
PARAMETER_CUSTOM, PACU,
 Command/Query, C-1
Parameters, 3-3, 7-8, 7-9
Parameters menu, 6-1
Pass/Fail, 5-2, 5-6
pctl histogram parameter, B-13
Peaks, B-2, B-3, B-4, B-5, B-9,
 B-12, B-13, B-14, B-19
Per.Hist
 see Persistence Histogram,
 4-2
Per.Trace
 see Persistence Trace, 5-2,
 5-4, 5-5, 5-6
Period
 Clock, 3-14
 Data, 3-15
 JitterTrack, 3-3, 3-15, 6-2
 Timing Parameter, 6-3, 6-8
pers of menu, 4-3, 5-3
Persistence
 map, 2-17
 see Persistence Trace, 5-3
 slice, 2-17, 2-18
Persistence Histogram, 2-17, 4-1
 horizontal cut, 4-2, 4-3, 4-4
 remote control command,
 C-11
 setup, 4-3

 slice, 4-2, 4-3, 4-4, 4-5
 vertical cut, 4-2, 4-3, 4-5
 when to use it, 4-2
Persistence map, 4-2, 5-4, 5-5,
 5-6
Persistence Map, 5-2
Persistence Trace, 2-18, 5-1, 5-2,
 5-4, 5-5, 5-6
 applications, 5-2
 average, 5-4
 processing Persistence, 5-2
 range, 5-6
 remote control command,
 C-12, C-13, C-14
 setup, 5-3
 shapes, 5-1, 5-2
 sigma, 5-5
 vector trace, 5-2
pks histogram parameter, B-14
Population, B-2, B-3, B-4, B-5,
 B-6, B-7, B-8, B-9, B-10, B-11,
 B-12, B-13, B-14, B-16, B-17,
 B-18
POSITION controls
 Histogram, 7-9
Pulse width, 2-18, 3-3

R

Rambus validation, 1-2, 2-9, 2-11,
 2-13
range, 5-1, 5-2, 5-3, 5-6, 7-1, 7-9,
 C-14
Range, B-16
 Histogram, 7-5, A-2
 Trend, A-2
range histogram parameter, B-16
REDEFINE A menu, 7-3, 8-2
REDEFINE... menu, 3-6, 4-3, 5-3
Reference Clock, 2-6, 3-1, 3-8
Reference frequency, 2-17
reference menu, 3-8, 6-11
Remote Control Commands
 Cycle-to-Cycle, C-5
 DEF, C-4
 Duty Cycle, C-6

Interval Error, C-5, C-7, C-8,
C-9
PACU, C-1
PERHIST, C-11
PERTRACE, C-12, C-13,
C-14
Width, C-10
RESET button, 7-5
Resolution, 3-13
rise, 5-4

S

Sample points, 3-3
scale in menu, 3-7, 3-8, 6-11
scale to menu, 5-3
Scaling, 7-6, 7-7
SDH, 2-17
Segments
 histogramming them, 7-9,
 A-1, A-2, A-3
 trending them, A-1, A-2, A-3
set menu, 3-7, 3-8, 6-11
Setup
 Histogram, 7-3, 7-6, 7-7
 JitterTrack, 3-6
 Persistence Histogram, 4-3
 Persistence Trace, 5-3
 Timing Parameters, 6-3
Setup/Hold, 1-3, 1-4, 2-3, 2-8
Setup menu, 7-6, 7-7
SETUP parameter menus, 6-4
show menu, 7-10
sigma, 5-1, 5-2, 5-3, 5-5, 7-9, A-5,
C-13
 multiples of, 5-5
sigma histogram parameter, B-17
Signal-to-noise ratio, 4-2
Single-shot, 5-4
Skew, 1-2, 1-4, 2-3, 2-6
Slice
 see Persistence Histogram,
 4-2, 4-3, 4-4, 4-5
Slope, 3-1, 6-4 – 6-7, 6-12
SONET, 2-17
source menu, 6-3, 6-10
standard, 3-8, 6-11

Standard Parameters, 5-4, 5-5,
5-6
Statistical distribution in
 using Histograms, 2-18
Statistical distribution in
 waveforms
 using Histograms, 7-2
Statistical Tools
 Histograms, 2-18
 Trends, 2-18
Statistics, 6-2, 7-8
Statistics menu, 6-1
Sweeps, 7-3, A-2

T

Telecom networks
 characterizing clocks in,
 2-17
tie@lv, 4-2, 6-2, 6-10, 6-11
Time cursor, 6-9, 7-10
Timebase, A-1
Timing Functions
 JitterTrack, 2-17
 Persistence Histogram, 2-17
 Persistence Trace, 2-18
Timing Measurements
 adjacent cycle deviation, 6-2
 clock or period accuracy, 6-2
 duty cycle, 6-2
 pulse width accuracy, 6-2
Timing Parameters, 2-18, 6-4,
7-1, A-3
 choosing them, 6-1
 for histograms, 7-2
 for Trends, 8-2
 guide to, 6-2
 histograms and trends, A-3
 in making histograms, 7-2
 setup, 6-4, 6-10
Tolerance mask
 created using Persistence
 Trace, 5-2
Total Population, B-18
totp histogram parameter, B-18
Trace
 configuring for a JTA tool,
 3-6, 4-3, 5-3



TRACE ON/OFF button, 7-4, 8-2

Trend

- accessing parameter setup during configuration, 8-4
- all or average, 8-4
- average or all parameters, 8-2
- calculation, A-1
- center and height, 8-2
- configuring for, 8-2
- maximum values in, 8-3
- overview, 2-18, 8-2
- parameter buffer, A-1
- parameter selection, 8-3
- range, A-2
- segmented waveforms, A-2, A-3
- using the tool, 8-1
- vs JitterTrack, 3-3, 3-4
- waveform acquisitions and trends, A-1, A-2
- zoom and positioning, 8-3, A-3

Trigger, A-1, A-2

type menu, 3-6, 5-3, 7-10

U

- use Math? menu, 3-6, 4-3, 5-3, 7-3, 8-2, 8-3
- using up to menu, 7-4, 8-3

V

Values, 7-3, 7-4, 7-5, 7-6, 7-7, 7-8, 7-9, A-2, A-3, B-8

Vector trace, 2-18

Vertical

Persistence Histogram cut, 4-3, 4-5

vertical menu, 7-7

Vertical time slice

Persistence Trace, 5-4, 5-5, 5-6

View, 2-5

W

wid@lv, 6-2, 6-5, A-3

Width

JitterTrack, 3-3, 3-16, 6-2

Timing Parameter, 6-5

Width menu

Histogram, 7-7, 7-9

Persistence Histogram, 4-4, 4-5

Wizard defaults, 2-5

X

xapk parameter, B-19

Z

Zoom, A-1

ZOOM + MATH, 3-6, 4-3, 5-3

ZOOM controls

Histogram, 7-9