

OPERATING INSTRUCTIONS

GA01423_0102

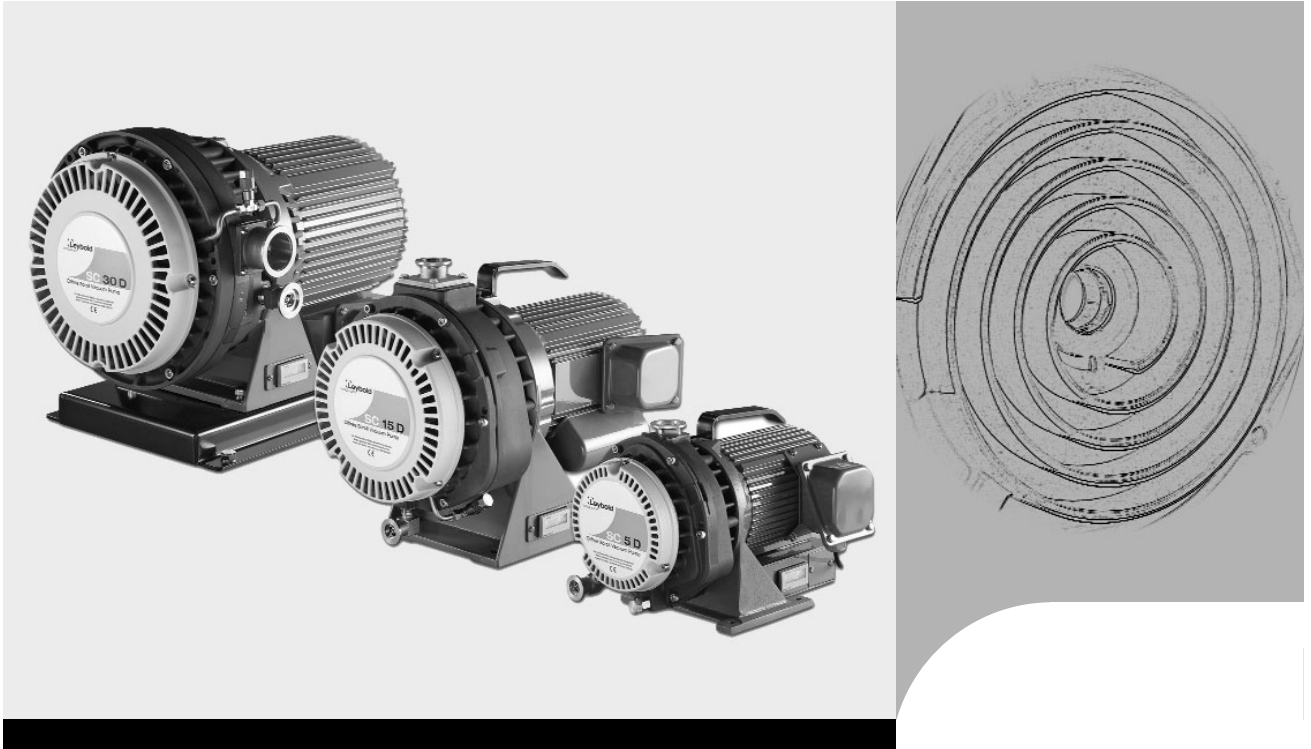

OIL-FREE SCROLL VACUUM PUMP

SC 5 D

SC 15 D

SC 30 D

Part Nos.

133 000	133 100	
133 001	133 101	133 003
133 002	133 102	133 004

 **Leybold**
vacuum

Contents

Section	Page
General safety information	3
1 Description	6
1.1 Name of each section	6
1.2 Order Information	8
1.3 Technical Data.	9
1.3.1 Motor Related Data.	10
1.3.2 Performance data	11
1.3.3 Outside dimensions.	12
2 Installation	15
2.1 Check the product	15
2.2 Operating environment	16
2.3 Setting up the pump	17
2.4 Electrical Connections.	18
2.4.1 Single-phase motors.	18
2.4.2 Three-phase motors	22
2.5 Connection to vacuum system	25
3 Operation	26
3.1 Start up.	27
3.2 Pumping	28
3.3 Pumping vapor (air flush operation)	28
3.4 Shut down	31
4 Maintenance	32
4.1 Table - Maintenance	34
4.2 Leybold Service.	35
4.3 Disposal	35
5 Troubleshooting	36
6 Spare parts	37
EC Conformance Declaration	38

Figures The first digit of a reference, (1/2) for example, is the figure number; the second digit is its item number in this figure.

We reserve the right to modify the design and the specified data. The illustrations are not binding.

General safety information

Indicates procedures that must be strictly observed to prevent hazards to persons.

Indicates procedures that must be strictly observed to prevent damage to, or destruction of the appliance.

The Leybold Oil-free Scroll vacuum pump is designed for safe and efficient operation when used properly and in accordance with this manual. It is the responsibility of the user to carefully read and strictly observe all safety precautions described in this section and throughout the manual. This product must be operated and maintained by trained personnel only. Consult local, state, and national agencies regarding specific requirements and regulations. Address any further safety, operation and/or maintenance questions to your nearest Leybold Vacuum office.

Failure to observe the following precautions could result in serious personal injury.

- Never pump toxic, explosive, flammable, corrosive gases, chemicals, solvents or powders.
Flowing substances, explosion or fire can cause bodily injury.
- Install in an area without explosive or flammable substances. Otherwise, it can cause explosion or fire.
- Wiring must be done by a qualified electrician. Otherwise, electric shock may occur.
- Prevent short-circuit with ground fault circuit interuptor (GFCI) of proper capacity.
Failure to do so can result in electric shock or fire.
- Ask specialist to perform repairs. If not , it can cause failure, damage or shorter lifetime. Trained customers may perform maintenance themselves.
- Be sure to install a main disconnect switch.
Failure to do so can result in damage, fire, or injury.
- Be sure to disconnect the electric source before wiring or inspection. Failure to do so can result in electric shock or damage by the rotating fan.
- Be sure to ground. Failure to ground can result in electric shock or fire.

Warning



Caution

Warning



Cut off electric Source



Be sure to ground



Safety information

Do not touch



Never put fingers or foreign matter into the pump's inlet or the clearance of cooling fins. If done, it can cause injury.

Avoid moisture



Install in an area which is not exposed to moisture such as rain or steam. Exposure to moisture can cause electric shock.

Do not alter



Never alter the equipment. Modifications can damage the equipment or shorten its lifetime.

With a thermal protector



Be sure to check Wiring diagram before connecting a power supply. Failure to do so can result in damage.

Pumps with single-phase motors have an internal thermal protector. This motor restarts without warning after the protector trips.

Be sure to switch off the electric power before maintenance or inspection. Failure to do so can result in electric shock or bodily injury by rotating objects.

Install in a proper location



Install in a proper location.

- Install on a level foundation (an inclination of less than 5°)
- in a location free of dirt or dust from iron, stone or wood.
- in a location free of corrosive gas.

Failure to install in a proper location can result in damage, decrease in performance or shorter lifetime.

Use designated temperature



Use at ambient temperatures of 5 - 40 °C (during operation). Operating outside of this range can cause damage or shorten lifetime.

Do not operate when the fan cover is removed.
Do not operate, when the terminal cover is removed.
Do not operate the single-phase pump when its condenser cover is removed.

Conduct periodic maintenance



Conduct periodic maintenance and inspections.
Failure to do so can cause damage or shorter lifetime.

Maintenance after pump is cool



Do the maintenance after the pump has fully cooled down.
Performing maintenance on a hot pump can cause burns.

Start or stop after closing isolation valve



Be sure to close the isolation valve between pump and vacuum system (chamber) during startup and shutdown.

If this valve is open, debris attached to inside of pump can be drawn back into the vacuum chamber.

SC 5 D

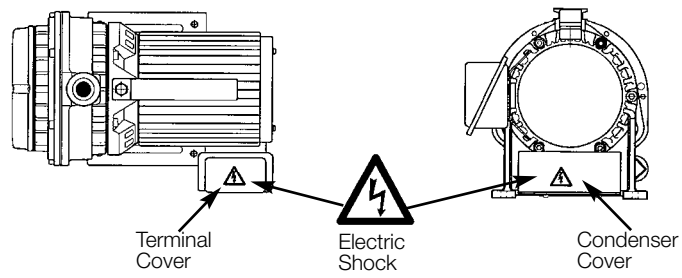

SC 15 D
Single phase

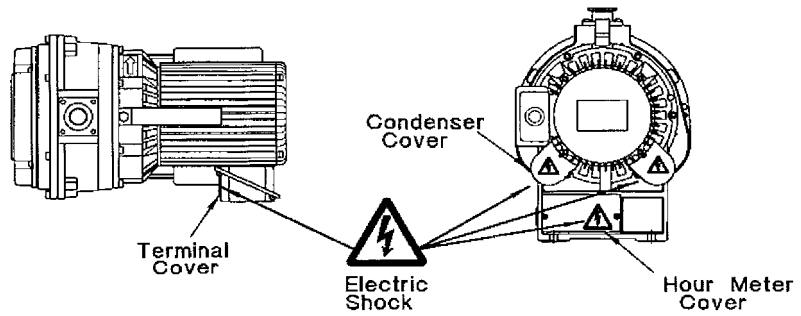

SC 15 D
Three phase

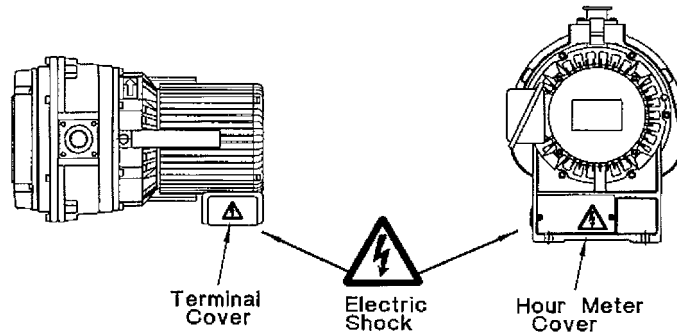

SC 30 D
Single phase

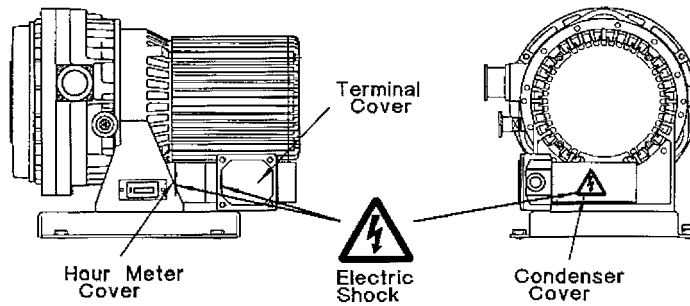

SC 30 D
Three phase

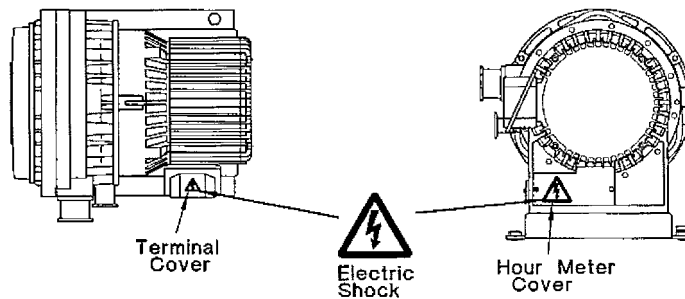

Always keep warning stickers clean. If they become dirty or lost, replace them with new ones. If you need stickers, contact Leybold.

Fig. 1 Where to attach warning stickers

1 Description

1.1 Name of each section

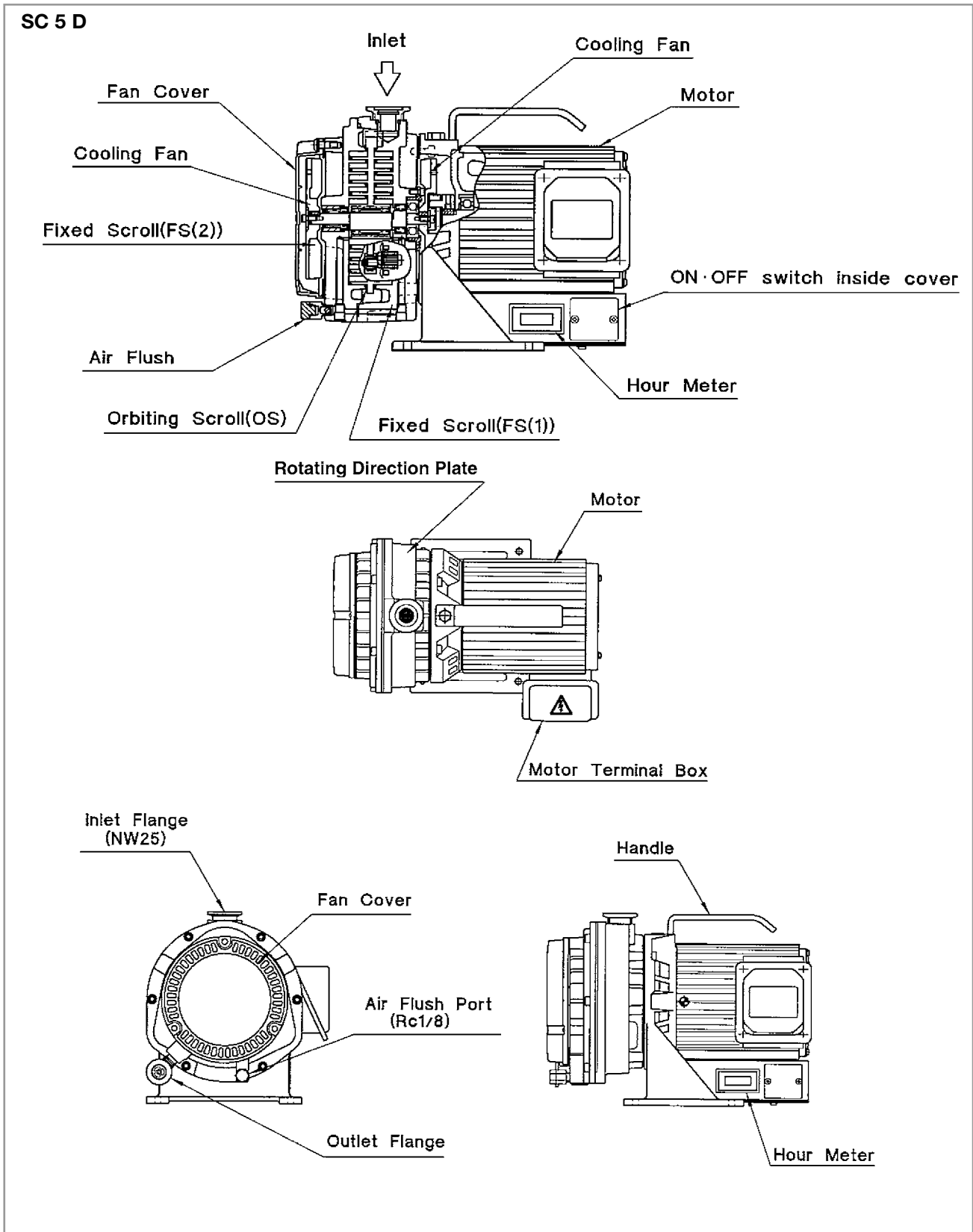
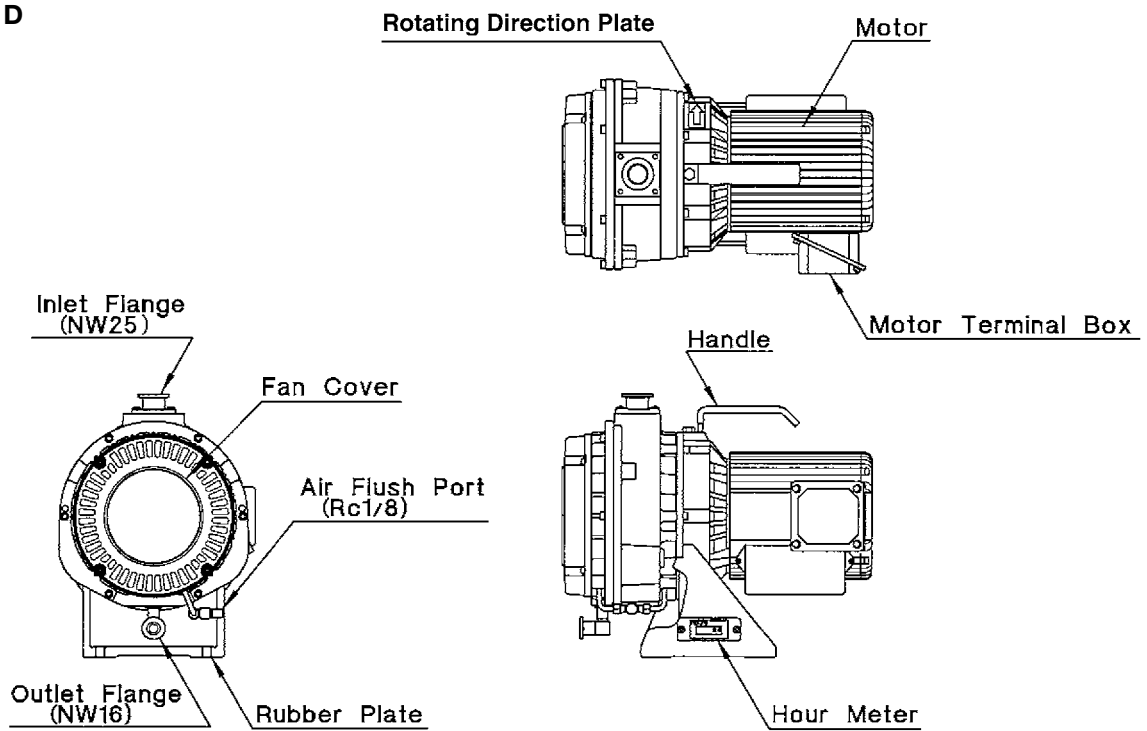

Fig. 2 Name of each section

SC 15 D



SC 30 D

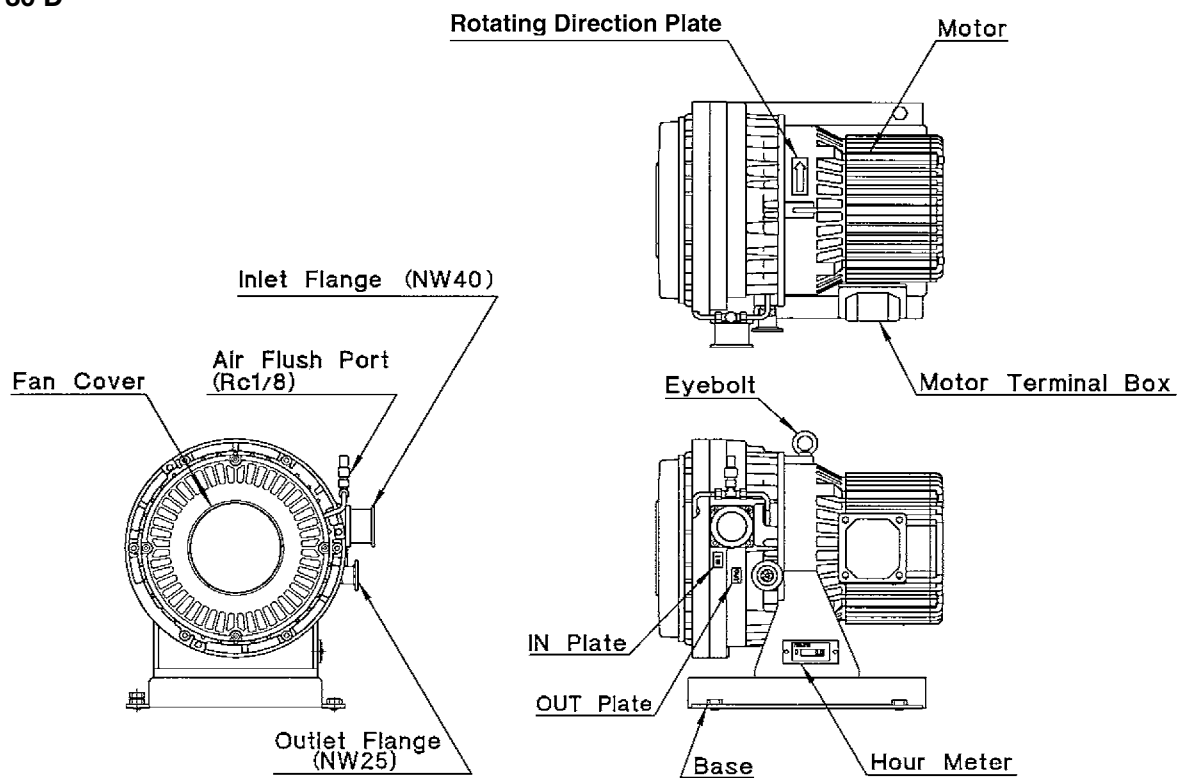

Fig. 3 Connections and controls (SC 15 D/30 D)

Description

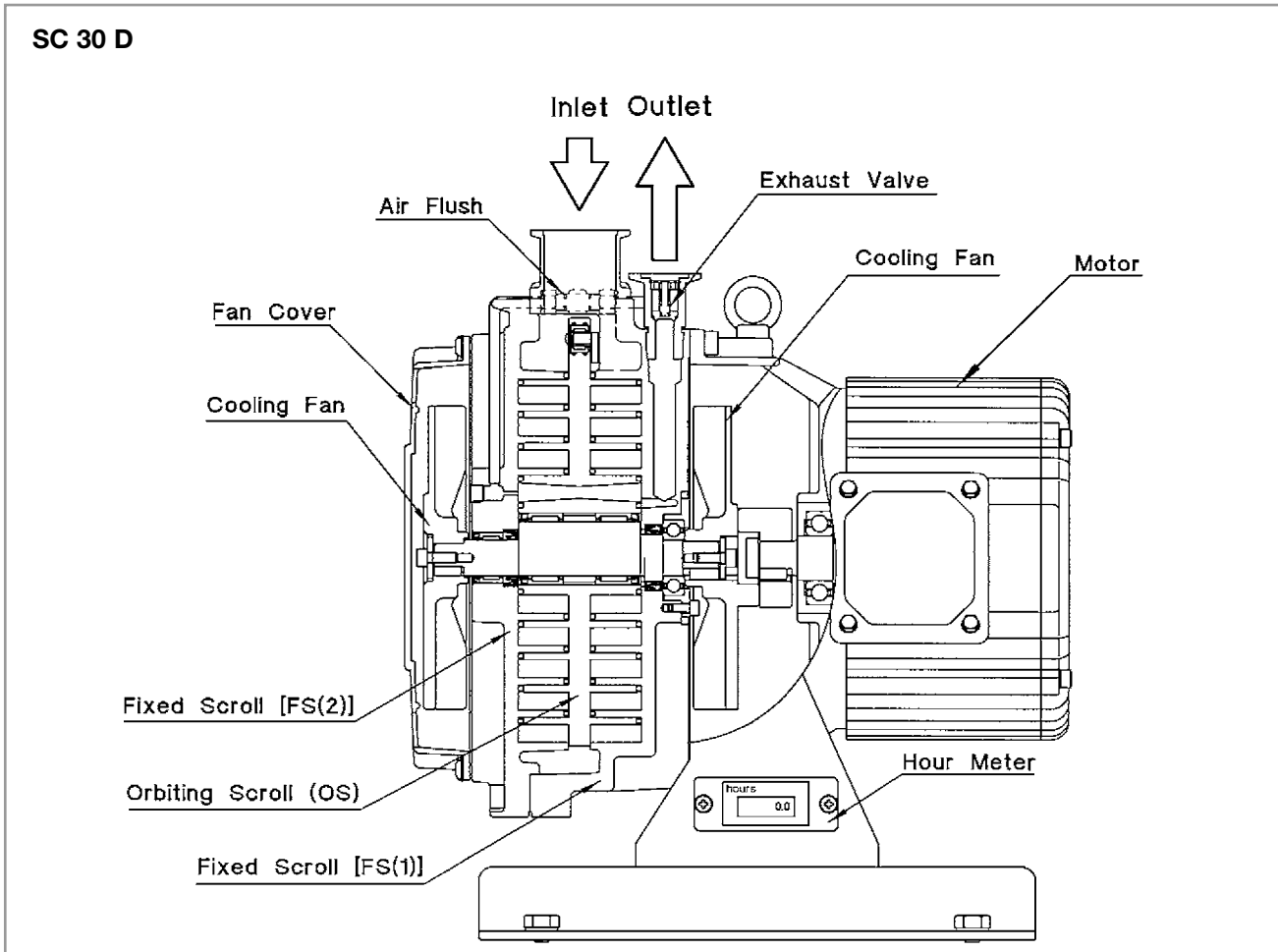

Fig. 4 Connections and controls (SC 30 D, 3-phase)

1.2 Order Information

	Part No.
SC 5 D, single-phase motor, cable with Schuko plug	133 000
SC 15 D, single-phase motor, cable with Schuko plug	133 001
SC 30 D, single-phase motor, cable with Schuko plug	133 002
SC 15 D, three-phase motor	133 003
SC 30 D, three-phase motor	133 004
SC 5 D, single-phase motor, cable with NEMA plug	133 100
SC 15 D, single-phase motor, cable with NEMA plug	133 101
SC 30 D, single-phase motor, cable with NEMA plug	133 102

1.3 Technical Data

Model		SC 5 D		SC 15 D		SC 30 D	
		50 Hz	60 Hz	50 Hz	60 Hz	50 Hz	60 Hz
Displacement (swept volume)	$\text{l} \cdot \text{min}^{-1}$	90	108	250	300	500	600
	$\text{m}^3 \cdot \text{h}^{-1}$	5	6.48	15	18	30	36
	cfm	3.1	3.8	8.8	10.6	17.6	21.2
Pumping speed ¹	$\text{l} \cdot \text{min}^{-1}$	80	93	210	230	420	500
	$\text{m}^3 \cdot \text{h}^{-1}$	4.8	6.2	13.6	16.4	26.3	31.5
	cfm	2.8	3.6	8	9.6	15.4	18.5
Ultimate pressure	Pa	≤ 5		≤ 1.6		≤ 1.0	
	mbar	≤ 0.05		≤ 0.016		≤ 0.01	
	Torr	≤ 0.037		≤ 0.012		≤ 0.0075	
Leak tightness ³	$\text{mbar} \cdot \text{l} \cdot \text{s}^{-1}$	$\leq 1.0 \cdot 10^{-6}$		$\leq 1.0 \cdot 10^{-4}$		$\leq 1.0 \cdot 10^{-4}$	
Max. inlet pressure		Atmospheric pressure					
Ambient operating temperature range	$^{\circ}\text{C}$	5 - 40		5 - 40		5 - 40	
Inlet connection	NW	25		25		40	
Outlet connection	NW	16		16		25	
Cooling system		Air-cooling					
Protection class	IP	20		20		20	
Class of equipment		Class 1					
Others		With hour meter and air flush					
Water vapor handling at 25 $^{\circ}\text{C}$, humidity 60 %, with opened air flush ⁴	g/day	5		25		25	
	$\text{l} \cdot \text{min}^{-1}$	9		10		10	

Description

1.3.1 Motor Related Data

Motor Related Data		SC 5 D				
Type	Single-Phase Induction / Motor 4P / Totally-Enclosed Insulation Class B IP 44 Thermal Protector TP 212 - Automatic Reset Type					
Power consumption	W	150				
Voltage	V	100	115	200	230	
Rated current	50 Hz	A	2.6	–	1.3	1.6
	60 Hz	A	2.1	2.2	1.1	1.1
Speed at	50 Hz	min ⁻¹	1430	–	1430	1440
	60 Hz	min ⁻¹	1730	1740	1730	1740
Noise level ² at 1m with air flush ON (opened)		dB(A)	≤ 52			
		dB(A)	≤ 57			
Direction of inlet	Vertical					
Dimensions (L x W x H)	mm	308 x 214 x 225				
Weight	kg	14				
Order information		133 100		133 000		

Motor Related Data		SC 15 D										
Type	Single-phase Induction motor 4P Totally-Enclosed Insulation Class B / IP 44 Thermal Protector TP 212 Automatic Reset Type					3-phase Induction motor ⁵ 4P Totally-Enclosed Insulation Class B / IP 44						
Power consumption	kW	0.4				0.4						
Voltage	V	100	115	200	230	200	208	230	380	415	460	
Rated current	50 Hz	A	4.8	*	2.6	2.4	1.6	*	*	0.9	1.0	-
	60 Hz	A	4.8	4.3	2.8	2.4	1.9	1.9	1.8	*	*	1.0
Speed at	50 Hz	min ⁻¹	1440	*	1430	1450	1420	*	*	1440	1440	*
	60 Hz	min ⁻¹	1710	1740	1700	1730	1660	1660	1690	*	*	1720
Noise level ² at 1m with air flush ON (opened)		dB(A)	≤ 58									
		dB(A)	≤ 66									
Direction of inlet	Vertical											
Dimensions (L x W x H)	mm	400 x 252 x 336				370 x 252 x 336						
Weight	kg	25				23						
Order information		133 101		133 001		133 003						

Motor Related Data		SC 30 D										
Type		Single-phase Induction motor 4P Totally-Enclosed Insulation Class B / IP 44 Thermal Protector TP 212 Automatic Reset Type					3-phase Induction motor ⁵ 4P Totally-Enclosed Insulation Class B / IP 44					
Power consumption	kW	0.6					0.6					
Voltage	V	100	115	200	230	200	208	230	380	415	460	
Rated current	50 Hz	A	8.5	*	4.3	3.9	2.7	*	*	1.57	1.63	-
	60 Hz	A	10	8.6	4.8	4.0	2.8	2.6	2.5	*	*	1.47
Speed at	50 Hz	min ⁻¹	1430	*	1430	1450	1460	*	*	1470	1470	-
	60 Hz	min ⁻¹	1660	1720	1690	1730	1740	1740	1760	*	*	1770
Noise level ² at 1m with air flush ON (opened)		dB(A)	≤ 62					≤ 60				
		dB(A)	≤ 70					≤ 68				
Direction of inlet		Horizontal (Laterally fitted)										
Dimensions (L x W x H)	mm	443 x 328 x 372 (443 x 298 x 397)					372 x 328 x 372 (372 x 298 x 397)					
Weight	kg	44					38					
Order information		133 102			133 002			133 004				

*Can not operate at 115V/50 Hz, 208V/50Hz, 230V/50Hz, 460V/50 Hz, 380V/60 Hz, or 415V/60 Hz.

Note 1 : Pumping speed remain the same when air flush is ON (opened) and OFF (closed).

Note 2 : Noise level is measured at ultimate pressure in an anechoic room.

Note 3 : Leak tightness is measured when pump is stopped and air flush is OFF (closed).

Note 4 : Air Flush is OFF (closed) when pump is delivered.

Note 5 : Three Phase Motor does not have internal thermal protection. Be sure to install thermal protection like a breaker.

1.3.2 Performance data

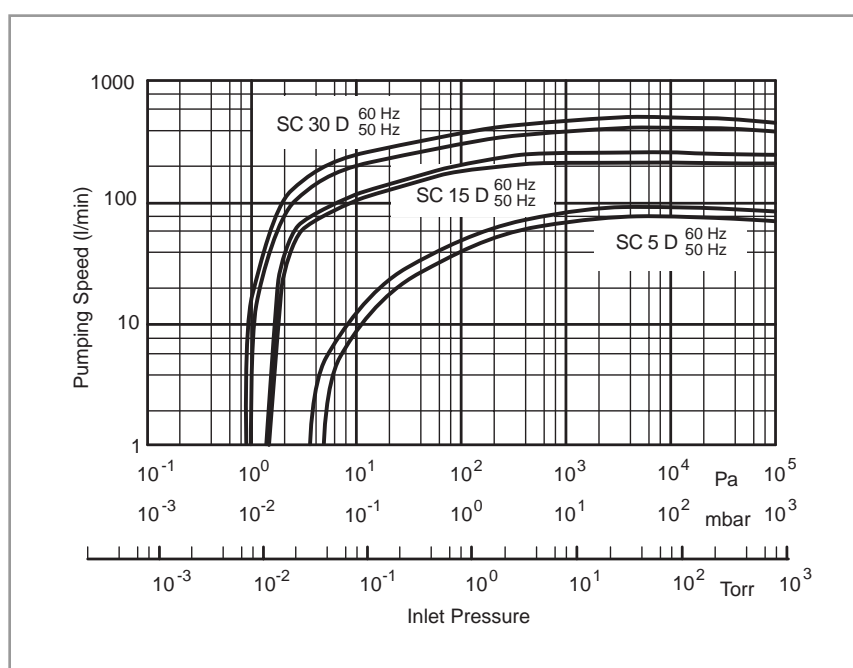

Fig. 5 Pumping speed characteristics

Description

1.3.3 Outside dimensions

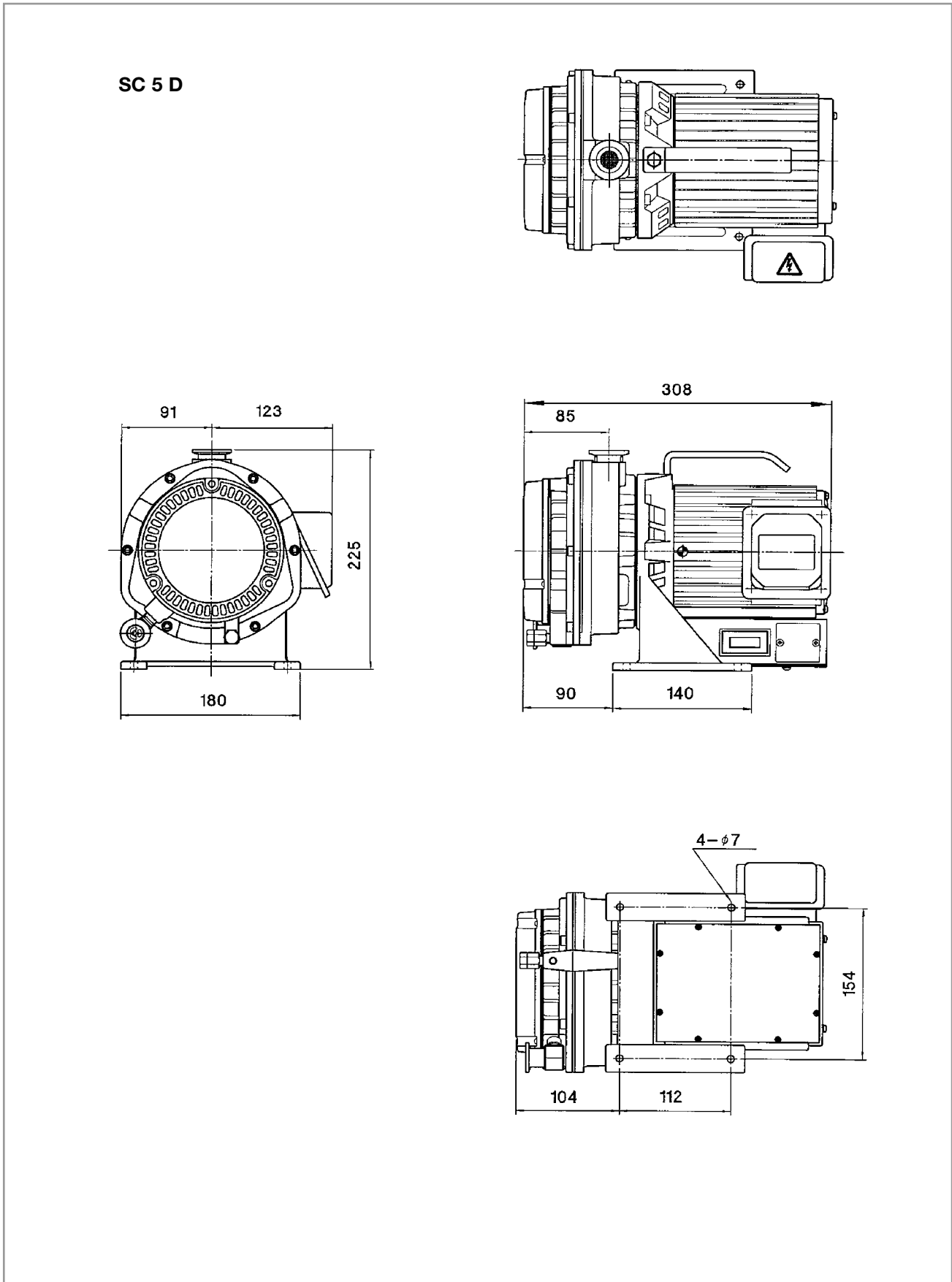

Fig. 6 Dimensional drawing for the SC 5 D

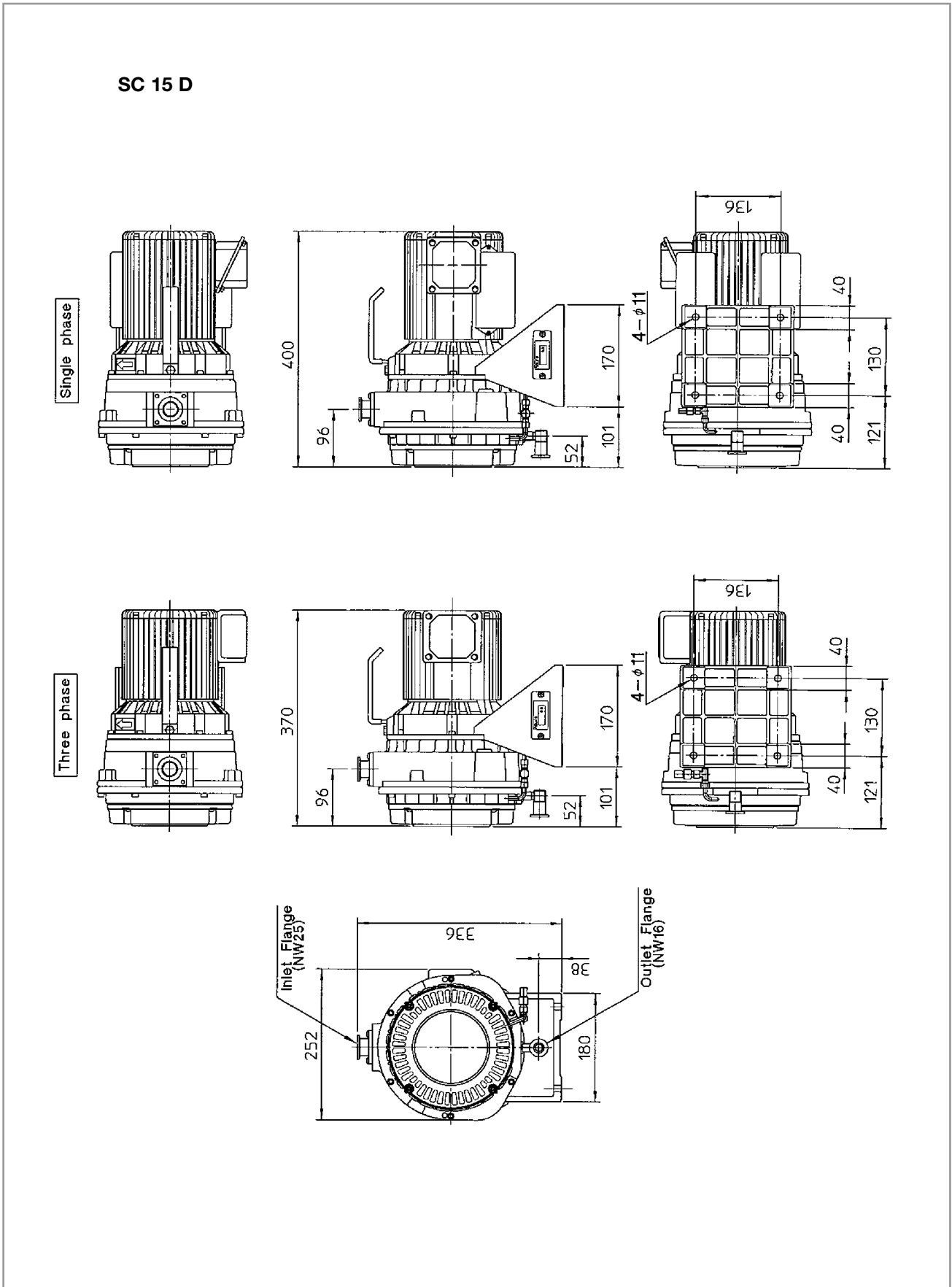
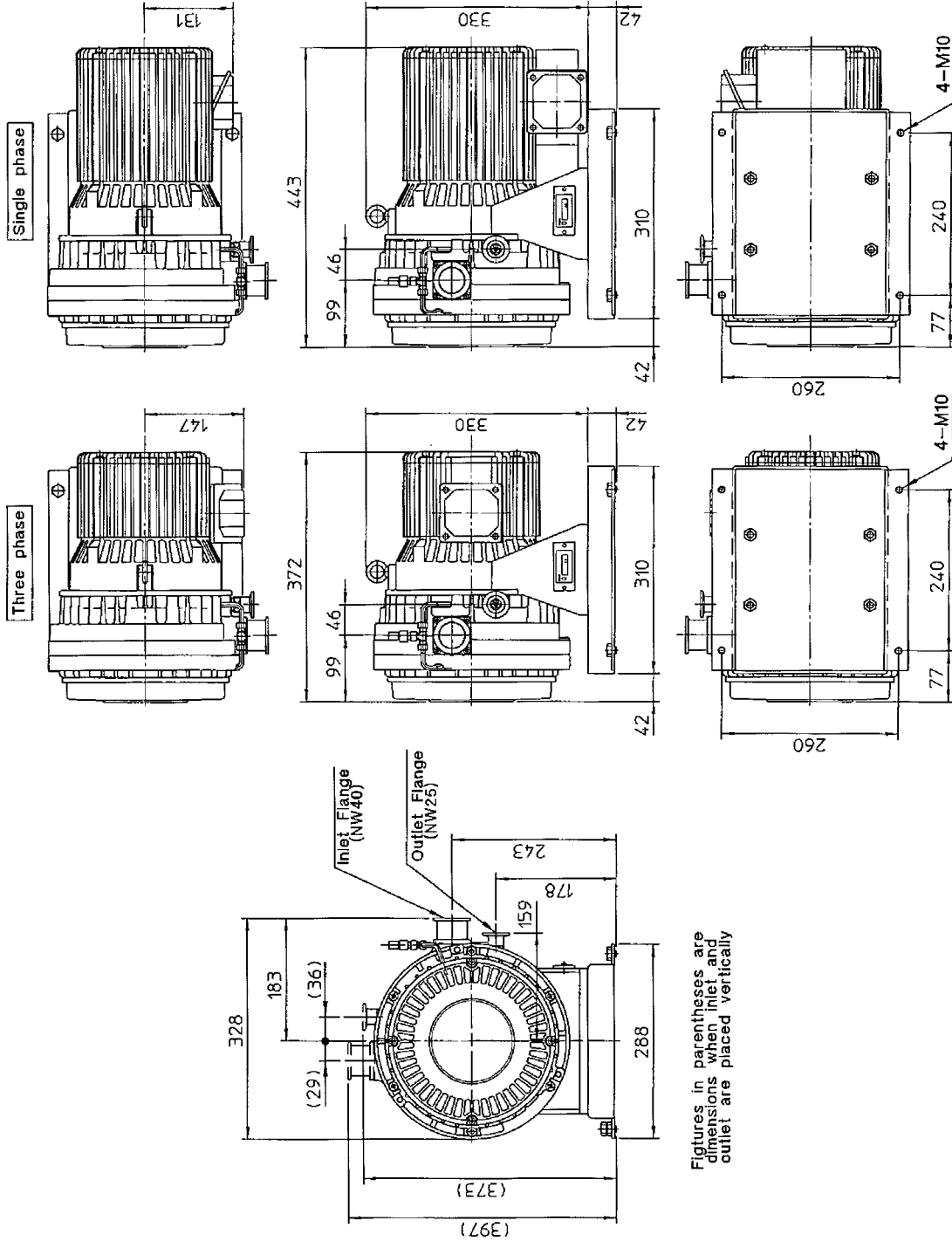

Fig. 7 Dimensional drawing for the SC 15 D

Description

SC 30 D



Figures in parentheses are dimensions when inlet and outlet are placed vertically

Fig. 8 Dimensional drawing for the SC 30 D

2 Installation

2.1 Check the product

- Check that the package is right-side-up and then open it.
- Check that model of the product is one that you ordered.
- Check that there is no damage. If there is any damage, file a damage claim with the carrier.
- Remove inlet blank flange and outlet blank flange. If you operate the pump with blank flanges, it can cause damage.
- Check that the Air Muffler for the Air flush port is in the plastic bag.

Caution

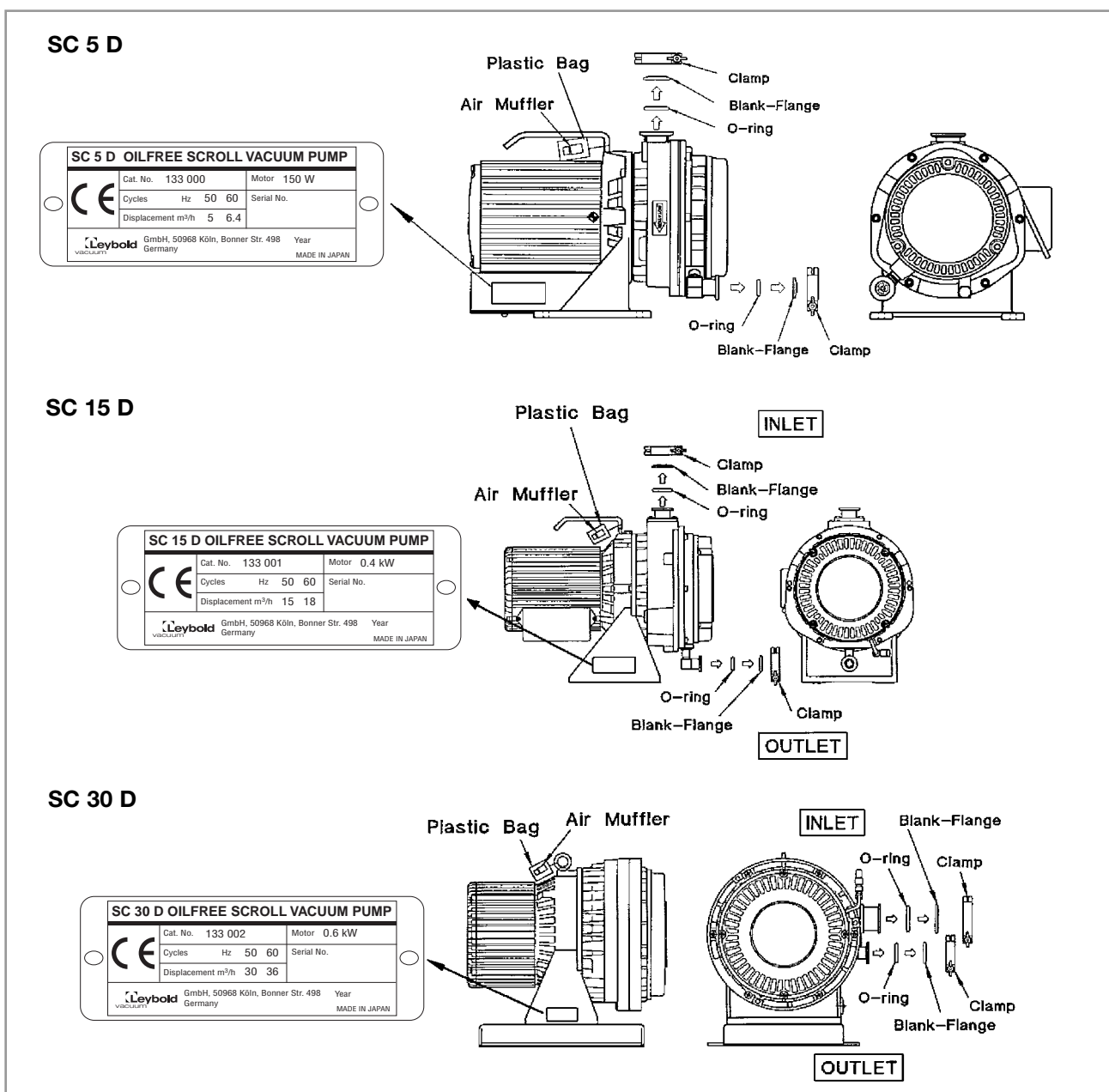

Fig. 9 Check the product

2.2 Operating environment

Be careful about moisture



Danger of electric shock.
Install in an area which is not exposed to moisture such as rain or steam.
Moisture on electric power connection can cause bodily injury by short circuit or electric shock.

Warning



Danger of explosion and fire.
Install in an area which is not exposed to explosives, flammable gas, or other related hazards.
Otherwise, the pump can cause an explosion or fire.

Temperature

Operate at ambient temperature of 5 °C - 40 °C. Operating outside of this ambient temperature range can cause damage, fire or failure.

Ventilation

Ensure proper ventilation.

Install in a well-ventilated area. Poor ventilation can cause abnormal overheating, fire or failure since the scroll pump is air-cooled.

Necessary ventilated air:

SC 5 D	over 2 m ³ · min ⁻¹
SC 15 D	over 4 m ³ · min ⁻¹
SC 30 D	over 8 m ³ · min ⁻¹

Avoid dust

Install in a proper location. Install in an area which is not exposed to dust or corrosive gas. Failure to install in a proper location can result in damage or failure.

Install the pump in an area which is not exposed to debris such as iron, stone, polishing or wood dust. Debris can clog air mufflers reducing the effectiveness of the Air Flush.

Avoid direct sunshine

Install in an area which is not exposed to sunshine. Direct sunshine can cause high temperature and failure.

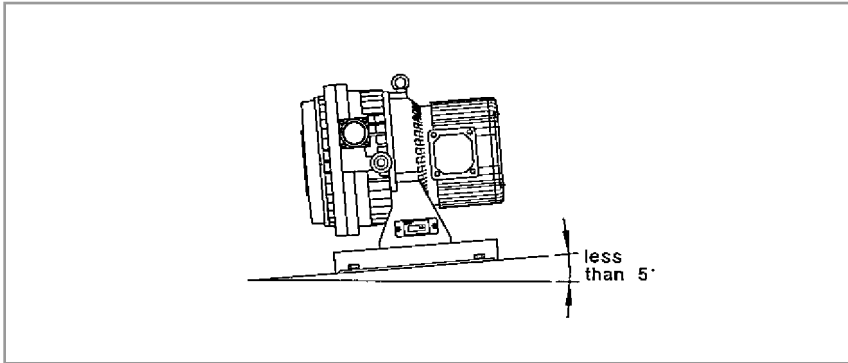

Fig. 10 Install on a firm, level floor

2.3 Setting up the pump

The SC 30 D is equipped crane eyelets for transport.

Use lifting devices with sufficient carrying capacity. Never stand beneath the suspended pump while it is being moved.

Warning



Install on a firm, level floor (less than 5 ° inclination). Uneven installation can cause failure.

If the floor is unstable, secure the pump by using

- 4 x Ø 7 mm holes of the pump leg (SC 5 D) or
- 4 x Ø 11 mm holes of the pump leg (SC 15 D) or
- 4 x M 10 tap screws on the pump base (SC 30 D).

2.4 Electrical Connections

Warning



Wiring must be done by a qualified electrician. Otherwise, electric shock or fire may occur.

Turn off power

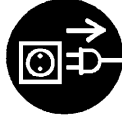

Turn off incoming main electrical power before wiring the pump. Failure to do so can cause injury from electric shock.

Check voltage



Check electric power and voltage before doing the wiring.

Three-phase motor has dual voltage 200/380V 50 Hz, 208/460 V 60 Hz.

Single-phase motor has dual voltage 100/200V 50 Hz, 115/208-230V 60 Hz.

Check electric source and voltage, and wiring.

2.4.1 Single-phase motors

Warning



Be sure to install a reliable main disconnect switch (or breaker) for emergency stop. In addition, shut off the SC 5 D by turning off the switch on the motor. Failure to do so can cause damage or fire.

Warning



The single phase motor has an internal thermal protector. The motor restarts without warning after the protector trips.

CE Requirement

Min. circuit current capacity of conductor is 10 A. Max. branch circuit breaker is 15 A (industrial rated).

Warning



Protect the motor by installing the recommended breaker. (refer to chart 1). Failure to do so can cause electrical shock or fire.

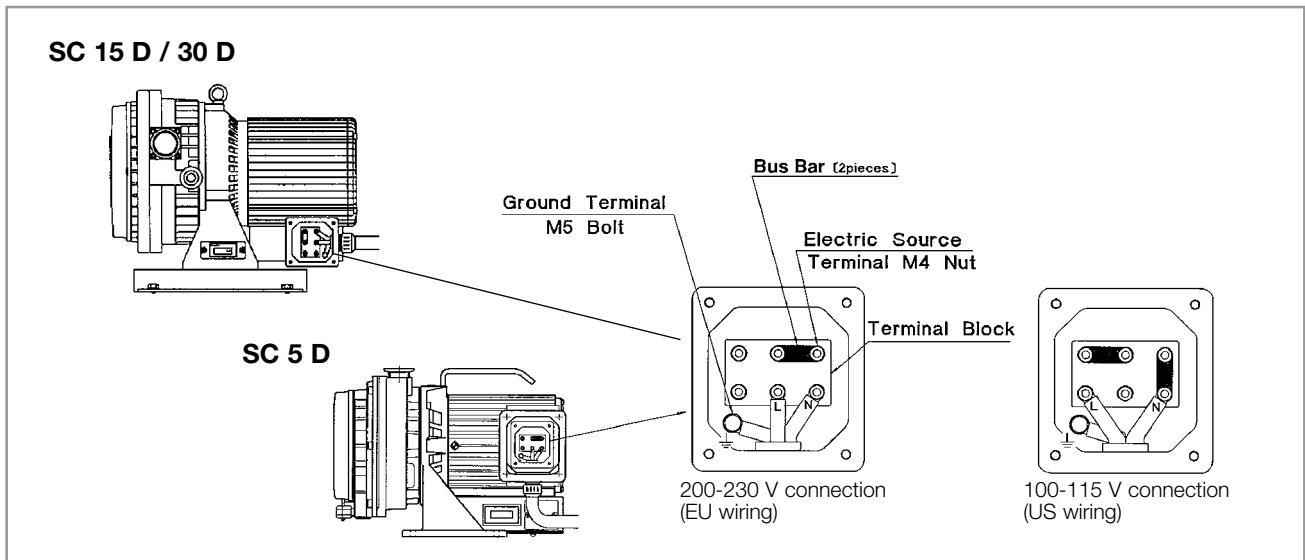

Fig. 11 Single-phase connection

When you use this pump in Europe

This vacuum pump must be equipped with a main disconnect device in accordance with requirements of EN 60204-1. It is recommended to use a circuit breaker as main breaker which is suitable for isolation according to EN 60947-2 and is equipped with an operating handle which is lockable in OFF position and complies with the other requirements of EN 60947-3.

Remove the terminal cover of motor and check the terminal block inside. The wiring diagram is shown inside the terminal cover.

You can change between 100-115 V and 200-230 V connection by changing the bus bars. If you want to change the connection, remove the M 4 nut for the power terminal and change the bus bars as illustrated in Figure 11. Two bus bars are used at the 200-230 V connection. Connect the power cord through the cable-gland on the bottom side of Terminal Box.

Activate the emergency stop by the main disconnect switch or breaker.

Protect the motor with a breaker.

Use power cord and ground wire rated at greater than 10 A.

Use round type terminal.

Fit cable-gland.

Connect ground wire to ground terminal.

After each modification of power supply cable wiring a new electrical safety test has to be done according to the national rules.

Warning



Installation

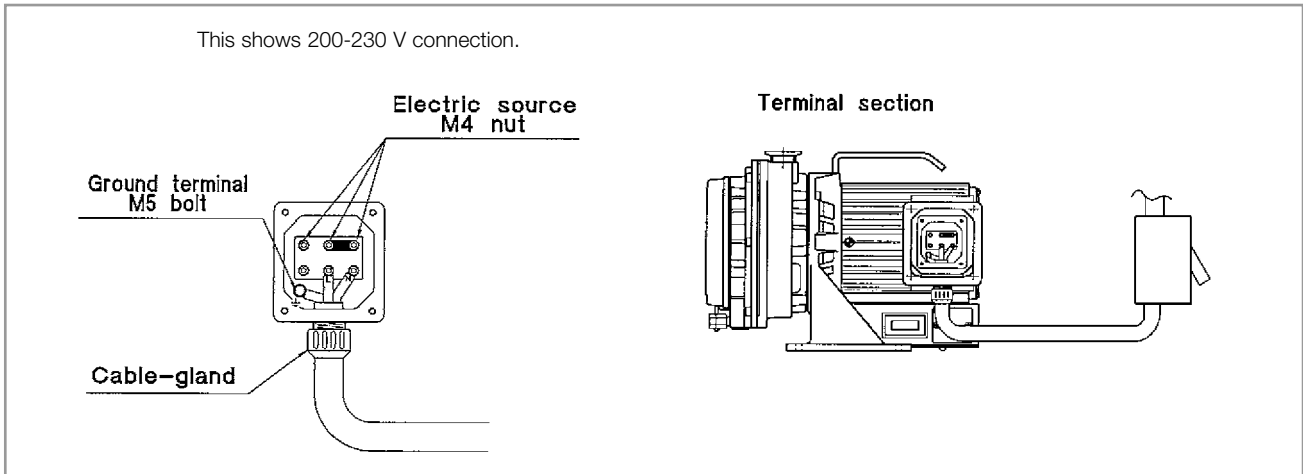

Fig. 12 Electrical connection (SC 5 D)

Chart 1: Single-phase specification				
V	Hz	Recommended breaker capacity - A		
		SC 5 D	SC 15 D	SC 30 D
100	50	3.0	6.0	10.7
100	60	2.5	6.0	12.5
115	60	2.5	5.4	10.8
200	50	1.5	3.0	5.4
200	60	1.3	3.2	6.0
230	50	1.9	2.7	4.9
230	60	1.3	2.7	5.0

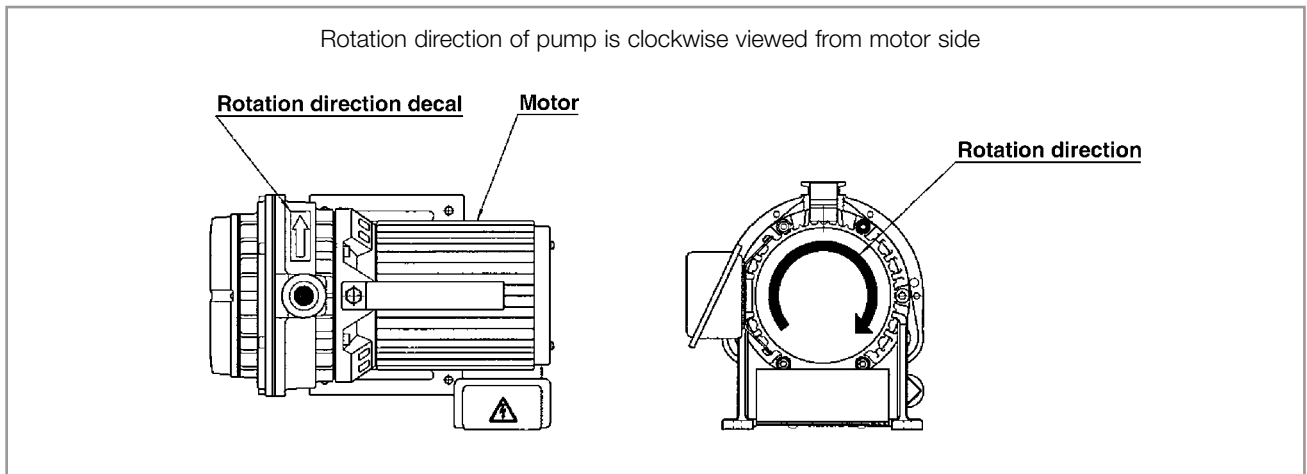

Fig. 13 Check rotation direction after wiring

Operate pump with inlet opened, and check that air comes out from outlet.

If you plan to switch the pump ON-OFF with remote control, check the pump's rotation direction before connecting it to the vacuum system.

When checking rotation direction, avoid dropping foreign matter into inlet. Dropping foreign matter into the pump can cause failure.

Caution

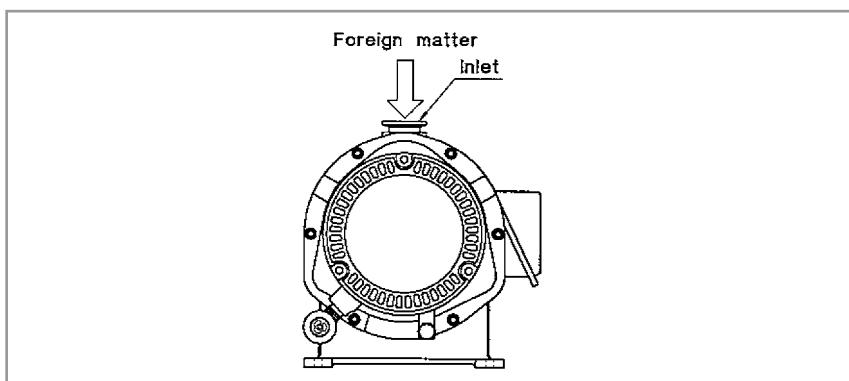

Fig. 14 Avoid dropping foreign matter inside

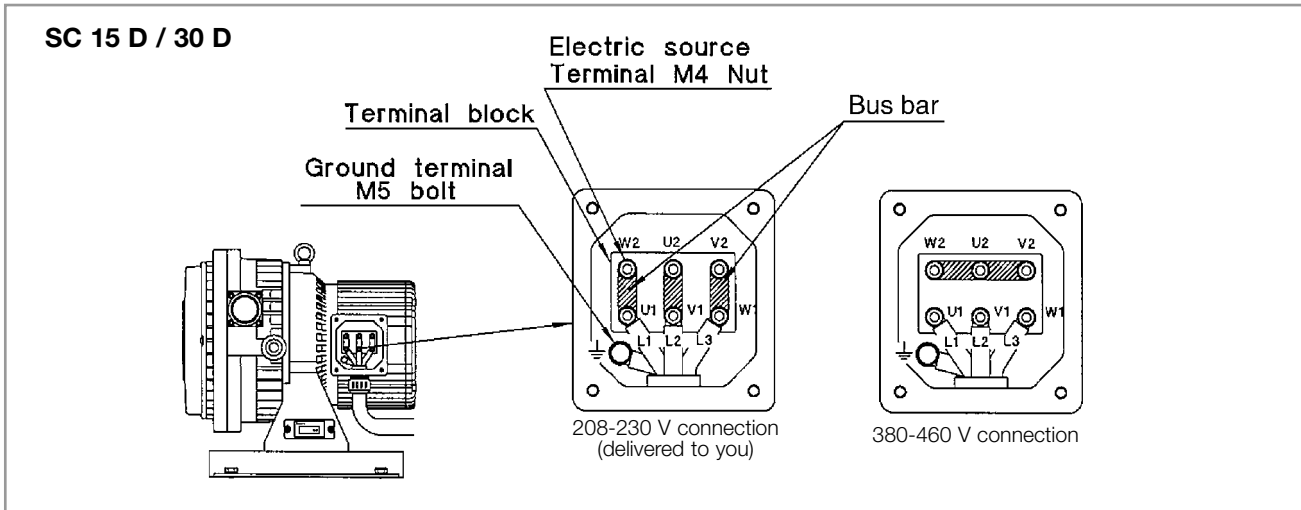

Fig. 15 Three-phase connection

2.4.2 Three-phase motors

For SC 15 D / 30 D only

Warning



Be sure to install a reliable main disconnect switch (or breaker) which meets the IEC standard for emergency stop. Failure to do so can cause damage or fire.

CE Requirement

The 3 phase-motor is not protected. External protection must be provided.

- Min. circuit current capacity of conductors is
SC 15 D - 3-phase 7 A ,
SC 30 D - 3-phase 15 A
- Max. branch circuit breakers is
SC 15 D - 15 A ,
SC 30 D - 15 A

Warning



Protect the motor by installing the recommended breaker. Failure to do so can result in injury from electrical shock or fire.

Use a power cord and ground wire of over 2 mm² (rated at 7 A, 3-phase for SC 15 D) (rated at 15 A, 3-phase for SC 30 D).

If the cord is underrated, it can cause injury from electrical shock or fire.

Firmly fit proper round crimp style terminal to electric cord with application device and connect to motor terminal. If the connection is loose, it can cause bodily injury or electrical fire.

Be sure to connect electric cord to terminal by using cable-gland at Ø 20 mm hole of motor terminal box. If the connection is loose, it can cause bodily injury or electrical fire.

Be sure to ground. Connect a ground wire to the ground terminal in motor terminal box. Failure to ground can cause bodily injury such as electric shock.

Warning



You can change to 208-230 V or 380-460 V connection by changing the bus bars. It is wired to 208-230 V connection when delivered to you. If you want to change to 380-460 V connection, remove electric source terminal M 4 nut and change the bus bars as illustrated in Figure 15. Connect the power cord through the cable-gland on the bottom side of Terminal Box. Connect L1-L2-L3 to U1-V1-W 1 terminals of the motor, respectively.

Activate the emergency stop by the main disconnect switch or breaker.

Protect the motor with a breaker.

Use a power cord and ground wire rated sufficiently.

Use round type terminal.

Fit cable-gland.

Connect ground wire to ground terminal.

After each modification of power supply cable wiring a new electrical safety test has to be done according to the national rules.

Warning



Three-phase specification			
V	Hz	Recommended breaker capacity - A	
		SC 15 D	SC 30 D
200	50	1.8	3.1
200	60	2.2	3.2
208	60	2.2	3.0
230	60	2.2	2.9
380	50	1.1	1.8
415	50	1.2	1.9
460	60	1.2	1.7

Installation

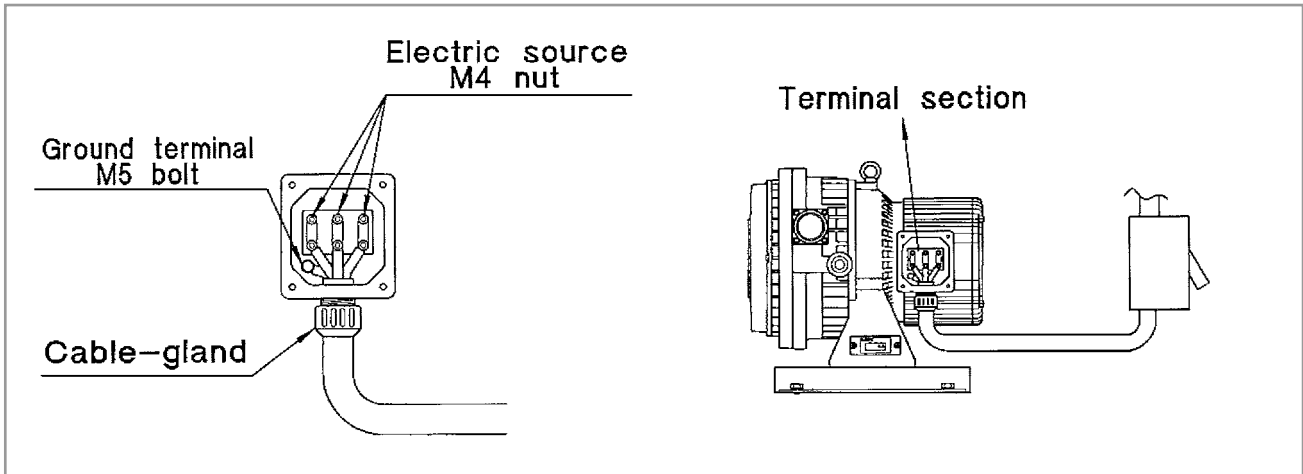

Fig. 16 Electrical connection (SC 30 D - 200 V)

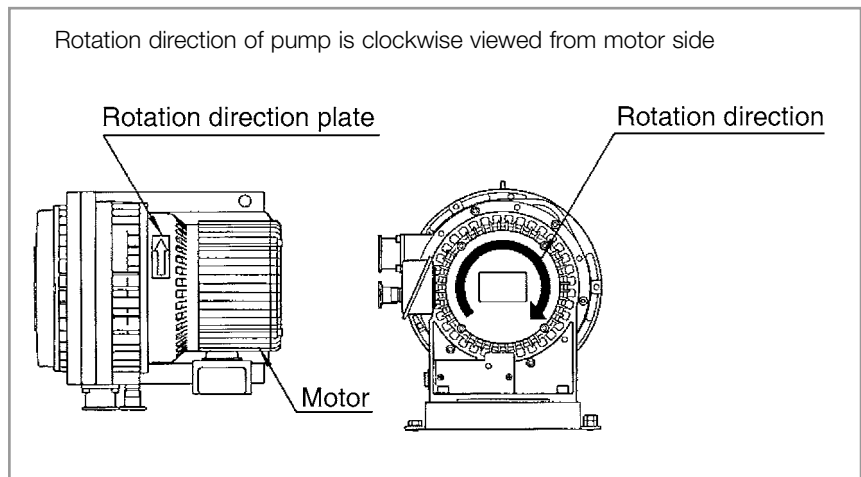

Fig. 17 Check rotation direction after wiring

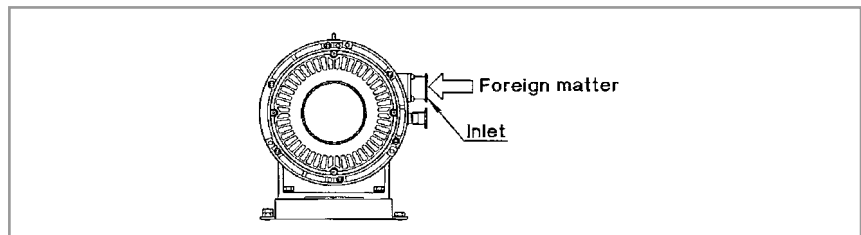

Fig. 18 Avoid dropping foreign matter inside

Operate pump with inlet opened, and check that air comes out from outlet.

If you plan to switch the pump ON-OFF with remote control, check the pump's rotation direction before connecting it to the vacuum system.

Caution

When checking rotation, avoid dropping foreign matter into the inlet. Dropping foreign matter into the pump can cause failure.

If the rotation is wrong, ensure that the incoming power is OFF and then interchange two of the input leads.

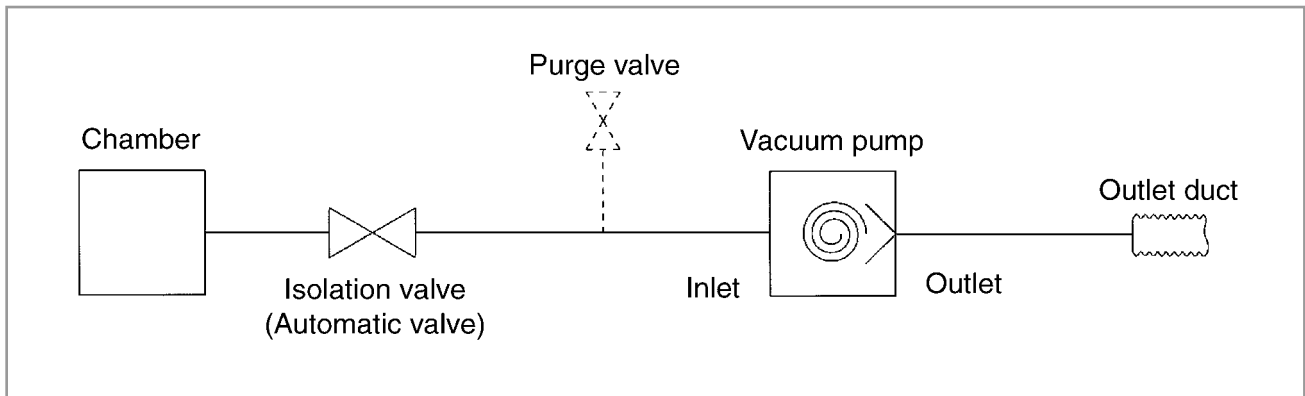

Fig. 19 Connection to vacuum system

2.5 Connection to vacuum system

- Inlet of SC 5 D is NW 25 and outlet is NW 16.
- Inlet of SC 15 D is NW 25 and outlet is NW 16.
- Inlet of SC 30 D is NW 40 and outlet is NW 25.
- Install an isolation valve between the vacuum chamber and the pump's inlet to prevent the drawback of debris from the vacuum pump into the vacuum chamber during start-up or shut-down.
- We recommend the use of an automatic valve as isolation valve which closes during power failurer to prevent the drawback of debris from inside the pump into the vacuum chamber.
- Install a purge valve between the isolation valve and the pump's inlet. Opening this purge valve during operation removes dirt and water vapor from the pump.
- Use the clean connecting tubing between vacuum chamber and vacuum pump. We recommend the use of flexible tubing between inlet of pump and the vacuum chamber so that the pump's vibration is not transmitted to the vacuum chamber.
- When connecting an exhaust line to the outlet of the vacuum pump, we recommend the following maximum straight length:
 - SC5D pump model 30 meters of NW 16 tubing
 - SC15D pump model 5 meters of NW 16 tubing
 - SC30D pump model 15 meters of NW 25 tubing
- Make sure that the exhaust line is not clogged during operation.
- Make sure that the pressure at the pump's outlet does not exceed atmospheric pressure.

3 Operation

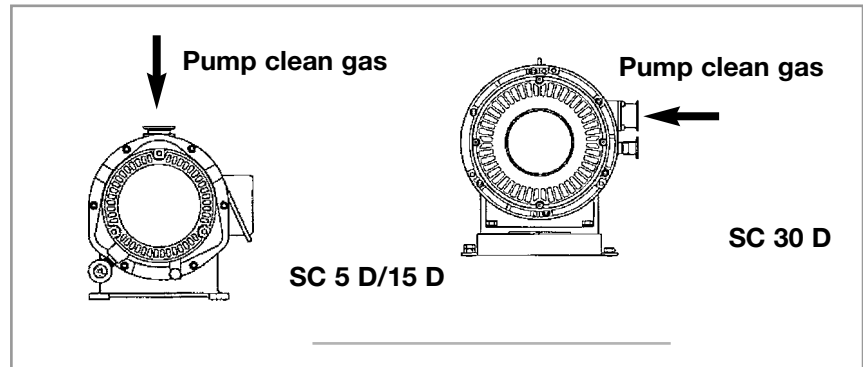

Fig. 20 Never pump hazardous gases



Do not pump hazardous gases to humans, or explosive, flammable, toxic or corrosive gases or substances which contain chemicals, solvents or powders. Pumping such gases can cause bodily injury from exposure to harmful substances, explosion or fire.

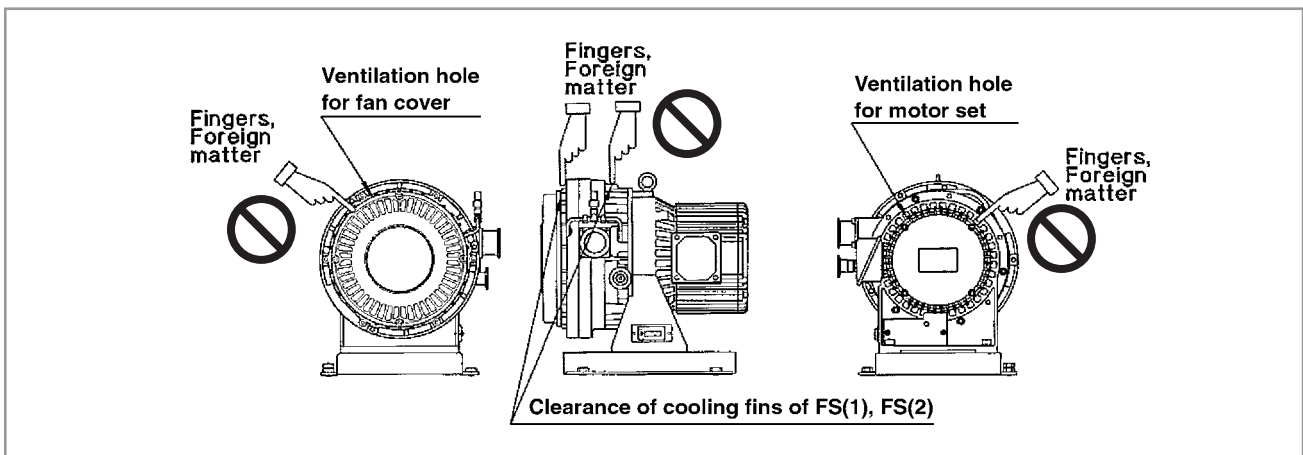

Fig. 21 Be careful about entanglement



Never put your fingers or foreign matter into ventilation holes of the fan cover, motor set or clearance between cooling fans of FS (1) and FS (2). If done, you can injure your fingers or foreign matter can blow into your eyes.

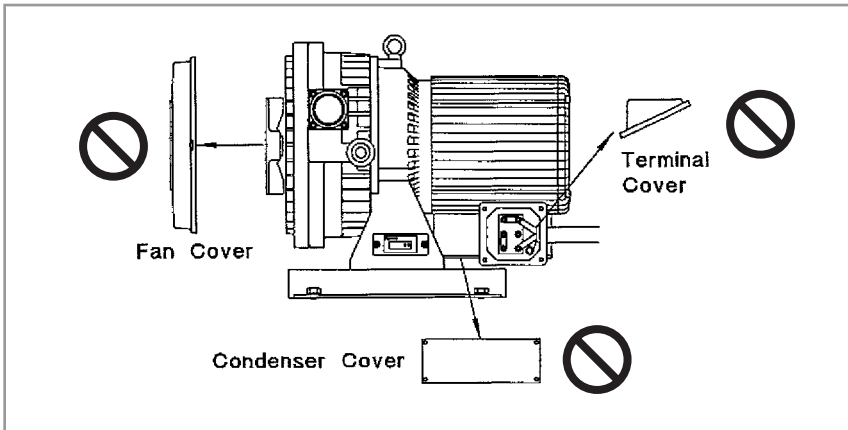

Fig. 22 Never alter equipment

Never remove or alter safety equipment or insulation parts. Removing or altering this equipment can cause electric shock or bodily injury by rotating objects.

Do not operate when the fan cover is removed.

Do not operate, when the terminal cover is removed.

Do not operate the single-phase pump when its condenser cover is removed.

Warning



3.1 Start up

Remove blank flanges from the inlet and outlet before starting the pump. Operation with blank flanges can cause damage.

Warning



If you will be pumping humid air or condensable vapors, open the Air Flush (refer to Sec. 3.3) before starting the pump as described below.

The pump takes 6-8 hours to reach its ultimate pressure during its initial start-up or after a long idle period.

Close the inlet isolation valve and continue operation for 6-8 hours opening the purge valve for 3-5 seconds to atmosphere 2-3 times per hour. While the pump was off, moisture may have entered the pump extending the time needed to reach ultimate pressure.

Close the isolation valve between the vacuum pump and vacuum chamber during start-up and shut-down of pump. Otherwise, debris from the pump can be drawn back into the vacuum chamber.

When restarting a pump that is already at operating temperature, open the purge valve for 3-5 seconds to atmosphere before restarting the pump. Otherwise, the pump's temperature can become unbalanced causing it to fail.

Proceed as follows to start the pump:

1. Close the isolation valve to prevent drawback of debris from the vacuum pump into vacuum chamber. (Open the purge valve if one is installed).
2. Switch the vacuum pump ON.
3. Open the isolation valve (close purge valve if one is installed) and pump the vacuum chamber.

3.2 Pumping

Operating the pump continuously near its ultimate pressure (for example, backing a turbomolecular pump) can cause deposits of foreign matter or moisture in the pump resulting in failure.

Operate with the Air Flush open (see below), or close the isolation valve and open the purge valve for 3-5 seconds to atmosphere several times once a day to remove foreign matter from inside the pump.

Operate at designated temperature

When pumping vapor, the inlet gas temperature must be less than 50 °C. When vapor temperature is more than 50 °C, install a chiller or trap in the piping between the vacuum chamber and the pump to reduce the inlet vapor temperature to less than 50 °C. Pumping vapor of over 50 °C can cause failure.

3.3 Pumping vapor (air flush operation)

Caution

When pumping vapor, open the Air Flush Port. If you pump vapor with the Air Flush Port closed, condensed moisture remains in the pump, resulting in failure.

Use care to avoid damaging the Air Flush Port (especially the air muffler).

When the Air Flush is open, noise level and ultimate pressure increases.

Purpose of Air Flush

The moisture volume drawn into pump varies depending on the temperature and pressure in the chamber. Pumping humid gas can result in moisture condensing in the pump. This remaining moisture can cause deterioration of the ultimate pressure or pump failure. When the vacuum chamber contains gas with humidity of over 60 % RH, the pump must be operated with the Air Flush open. Operating the pump with the Air Flush open removes the moisture which allows the pump to reach its ultimate pressure.

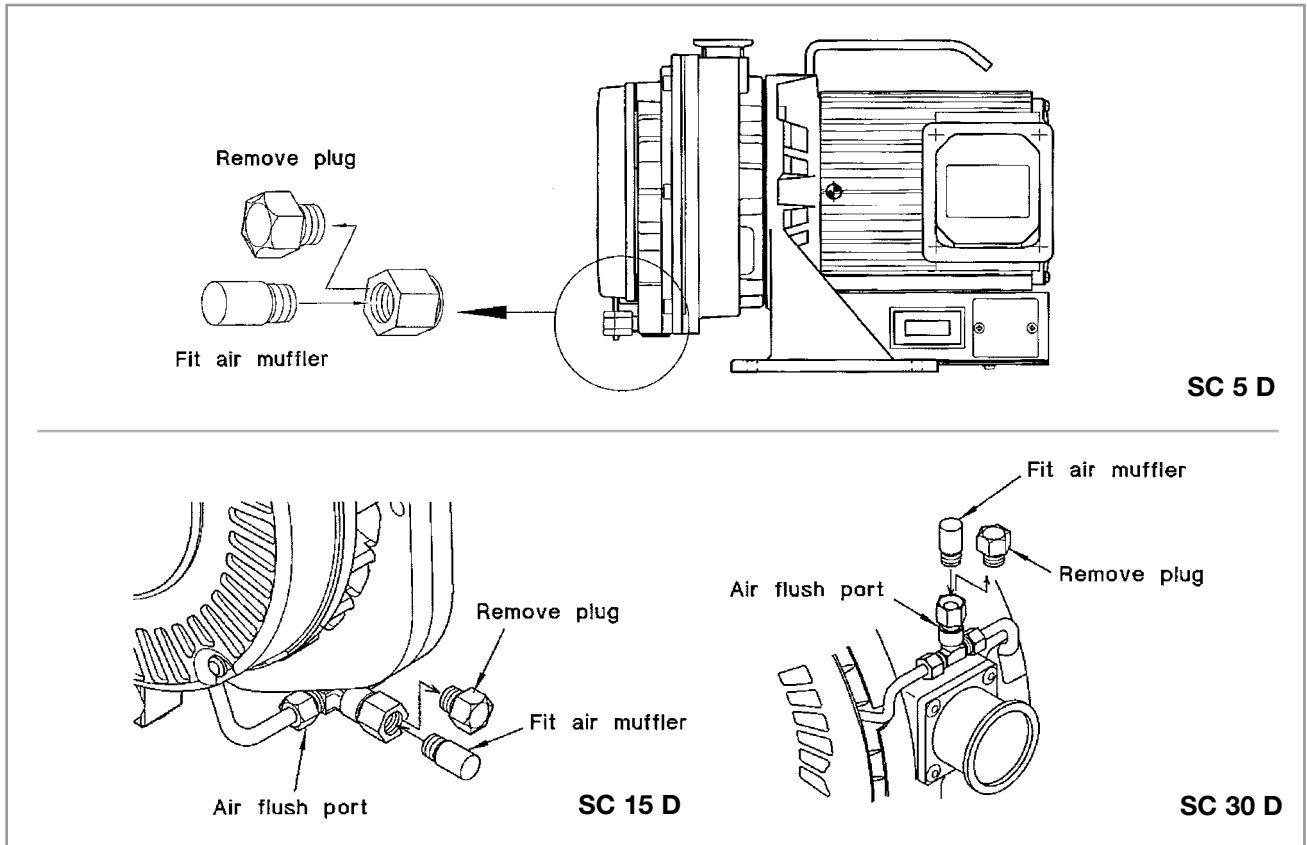

Fig. 23 Operate with Air Flush Port opened

Never change Air Flush condition ON-OFF during operation.

Open or close the Air Flush Port only after shutting down the pump. Opening or closing the Air Flush during operation can cause the pump to fail and cause bodily injury.

Caution

To open the Air Flush, shutdown the pump, remove the plug from the Air Flush Port and screw the air muffler into the Air Flush Port.

To close the Air Flush, shutdown the pump (see below), remove the Air Muffler from the Air Flush Port and replace it with the plug. Lightly tighten the plug with a wrench.

When supplying nitrogen gas or dry air to the air flush port, set the pressure equivalent to atmospheric pressure while keeping the flow less than

- $9 \text{ l} \cdot \text{min}^{-1}$ for the SC 5 D or
- $10 \text{ l} \cdot \text{min}^{-1}$ for the SC 15 D and SC 15 D.

Exceeding 9 or 10 l/min air flush can cause pump failure.

Caution

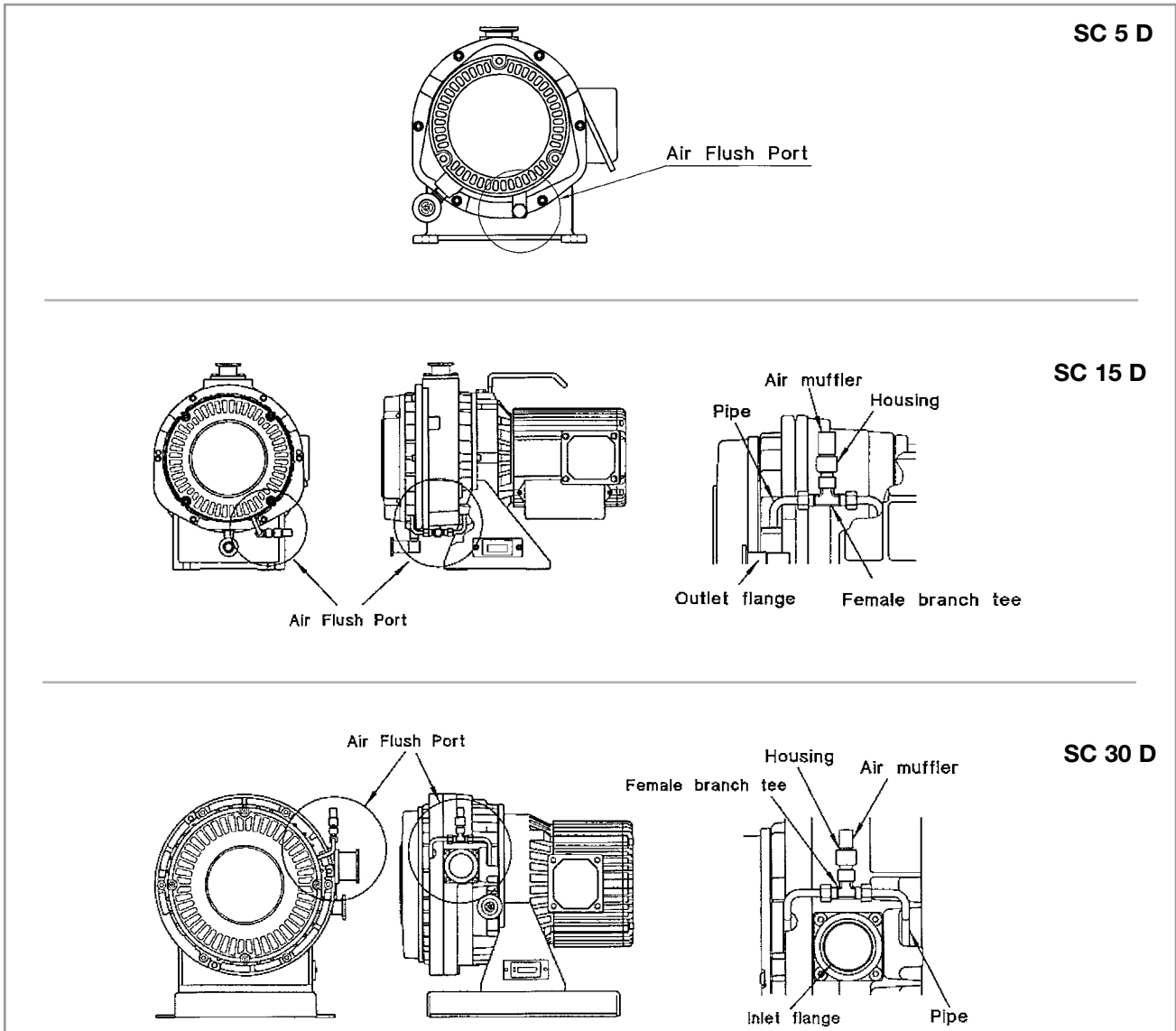

Fig. 24 Position of Air Flush Port

3.4 Shut down

After vapor is pumped, continue to operate with the Air Flush open for over one hour. If you close Air Flush Port or stop the pump soon after vapor is pumped, condensed moisture remains in the pump, resulting in failure.

- To prevent the drawback of debris from the vacuum pump into vacuum chamber during shutdown, close the isolation valve (open the purge valve if one is installed).
- Switch the vacuum pump off.

When the pump stops, atmospheric air is drawn back from the Air Flush Port to the inside of pump, and pressure inside pump becomes about atmospheric pressure. To maintain vacuum in the vacuum chamber and prevent the drawback of debris from vacuum pump into vacuum chamber, close the isolation valve to the vacuum chamber before shutting off the pump.

Warning



4 Maintenance

Caution

Neglecting maintenance and inspection can cause poor performance and pump failure.

To remove debris accumulated in the vacuum pump, operate the pump several times for 3-5 seconds (once a day) with its inlet open to atmospheric air (or open the purge valve if one is installed).

Warning



Allow the pump to cool down before doing maintenance. Performing maintenance immediately after shutdown can cause bodily injury such as burns.

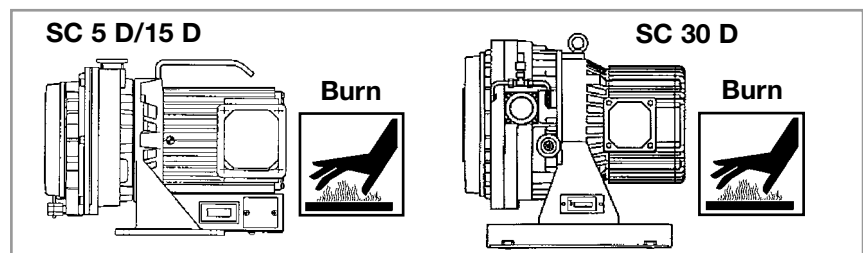

Fig. 25

Warning



Be careful of automatic restart

The thermal protection on the single-phase motor automatically resets. This motor restarts without warning after the protector trips. Be sure to switch off the electric power before maintenance or inspection.

Warning



Switch off electric source

Be sure to switch off the electrical power before maintenance or inspection. Failure to do so can cause bodily injury from electric shock or rotating objects.

Caution

More frequent maintenance is required if ambient temperature is too high. The maintenance interval is based on 5 - 40 °C ambient temperature and 25 °C average yearly temperature.

Shorten the maintenance interval if the ambient temperature is higher. Otherwise, the pump may fail prematurely.

The maintenance schedule assumes the pump is exposed to clean gas

You must shorten the maintenance interval when pumping vapor since vapor temperature, disposal volume, disposal frequency and substances in the vapor influence the pump's operation.

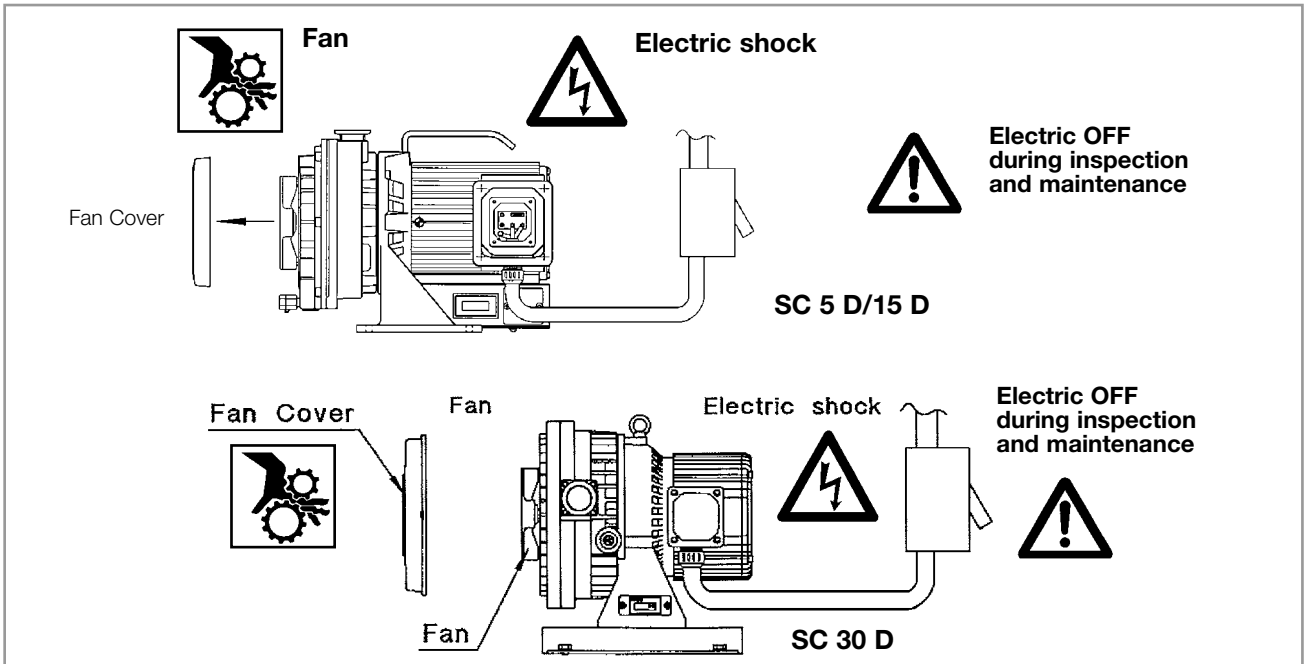

Fig. 26

4.1 Table - Maintenance

When the maintenance interval has been reached, contact Leybold to arrange the required maintenance. Never disassemble, reassemble or alter the pump yourself. We are not responsible for any accidents caused by disassembly, assembly or alteration which was done by the user or non specialist.

Where to inspect	Maintenance interval			Remarks
	Yearly or every 8.000 hr	Biennially or every 16.000 hr	every 400 times vapor pumping	
Needle bearing - FS (2)	grease / ▲	●	▲	
Needle bearing - OS	grease / ▲	●	▲	
Ball bearing - FS (1)	▲	●	▲	
Needle bearing (Pin crank)	grease / ▲	●	▲	
O-ring (Pin crank, Needle bearing)	▲	●	▲	
Spider	▲	●	▲	
Seal (Pin crank, Needle bearing)	●	●	▲	only SC 30 D
Shaft seal (2) - FS (2)	●	●	▲	
Shaft seal (1) - FS (1)	●	●	▲	
G seal - FS (2)	●	●	▲	
G seal - OS	●	●	▲	
G seal - FS (1)	●	●	▲	
Exhaust valve set	●	●	▲	
O-Ring (Outlet flange)	●	●	▲	only SC 15 D
O-ring - FS (2)	●	●	▲	
O-ring (Inlet flange)	●	●	▲	
Tip seal set (1)	▲	●	▲	
Tip seal set (2)	▲	●	▲	
Pin crank set	▲	▲	▲	
Air flush kit	●	●	●	

- Replace
- ▲ Replace if something goes wrong

Note 1: Be sure to use designated DIS exclusive grease.

Note 2 :The maintenance interval is the time interval or running hours whichever is reached first.

4.2 Leybold Service

If you send a pump to Leybold indicate whether the pump is free of substances damaging to health or whether it is contaminated. If it is contaminated also indicate the nature of hazard. To do so, you must use a pre-printed form which we shall send to you upon request.

A copy of this form is printed at the end of the Operating Instructions: "Declaration of Contamination of Vacuum Equipment and Components". Another suitable form is available from the Leybold homepage: www.leybold.com under the headline "support & download".

Please attach this form to the pump or enclose it with the pump.

This "Declaration of Contamination" is required to meet German Law and to protect our personnel.

Leybold must return any pumps without a "Declaration of Contamination" to the sender's address.

The pump must be packed in such a way, that it will not be damaged during shipping and so that any contaminants are not released from the package.

4.3 Disposal

The pump may be contaminated by the process or by environmental influences. In this case it must be decontaminated in accordance with the relevant regulations. Leybold offers this service for fixed prices. Further details are available on request.

Contaminated parts can be detrimental to health and environment. Before beginning to work, find out whether any parts are contaminated. Adhere to the relevant regulations and take the necessary precautions when handling contaminated parts.

Separate clean components according to their materials, and dispose of.

If you send a pump to Leybold mind the regulations given in Section "4.2 Leybold Service".

Contamination

Form

Warning



Contamination

Warning



5 Troubleshooting

If the pump malfunctions, please refer to the following chart for help in solving the problems.

If you cannot solve the problem, please contact Leybold.

Fault	Possible cause	Remedy	
Pump does not rotate.	Breaker malfunction.	Inspect and repair.	
	Wiring becomes loose or cut.	Repair or replace.	
	Voltage drops.	Check length and size of cable.	
	Motor malfunctions.	Inspect and repair.	
	Pump malfunctions.	Inspect and repair.	
	only SC 5 D	Switch is turned OFF	Turn switch ON.
	only SC 5 D	ON-OFF switch is damaged.	Replace.
		Thermal protector trips.	Inspect connection in thermal box.
			Inspect wiring.
			Inspect voltage.
		Inspect and repair.	
Ultimate pressure is Insufficient.	Air leaks for pumping.	Check tightness of piping.	
	Moisture or solvent has condensed in pump.	Open inlet to atmosphere and operate for a few minutes and then operate for about 24 hours with the inlet closed. Install a trap or a filter to prevent water and solvent from entering the pump.	
	O-ring is damaged.	Replace.	
	Air flush port is clogged.	Clean air muffler. - Replace	
Abnormal sound, vibration.	Connection becomes loose.	Tighten connection.	
	The pump is not level.	Level the pump.	
	Foreign matter enters inside of Pump.	Inspect and repair.	
	Failure of exhaust valve.	Inspect and repair.	
	Failure of motor.	Inspect and repair.	
	Failure of pump.	Inspect and repair.	

6 Spare parts

Parts name	SC 5 D	SC 15 D	SC 30 D
Major service kit	EK870000499	EK870000500	EK870000501
Minor service kit	EK870000496	EK870000497	EK870000498

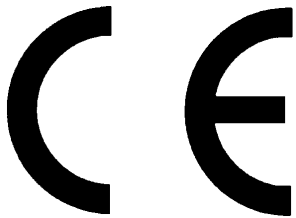

EC Conformance Declaration

We, the Leybold Vacuum GmbH, declare herewith that the products listed below, in the embodiment which we have placed on the market, comply with the applicable EC guidelines.

This declaration becomes invalid if modifications are made to the product without consultation with us.

Compliance with the EMC guideline requires that the components be installed within the system or machine in a manner adapted to EMC requirements.

The tests are performed on a normal measurement workbench using an arrangement typical for the type of system.

Date of CE approval (year): 2004

Designation of the products: **Scroll-Vakuumpumpen**

Models:	SC 5 D	Part Nos.:	133 000	133 100	
	SC 15 D		133 001	133 101	133 003
	SC 30 D		133 002	133 102	133 004

The products comply to the following guidelines:

- EC Machinery Directive (98/37/EG) and (98/79/EG)
- EC Low Voltage Directive 73/23/EWG and 93/68/EG
- EC Directive Electromagnetic Compatibility
89/336/EWG, 91/263/EWG, 92/31/EWG and 93/68/EWG

Related, harmonized standards:

- EN 1012-2 1996
- EN 60204-1 1997
- EN 60034-1/A11 1998/2002

Cologne, 17.12.2004

Marcus Eisenhuth
Member of the Executive Board
Head of Product Development

Cologne, 17.12.2004

Hans Rottländer
Product Manager

Leybold Vacuum GmbH
Bonner Strasse 498 (Bayenthal)
D-50968 Cologne
Phone: ++49 (0)221 347-0
Fax: ++49 (0)221 347-1250
documentation@leybold.com

www.leybold.com

Declaration of Contamination of Compressors, Vacuum Pumps and Components

The repair and / or servicing of compressors, vacuum pumps and components will be carried out only if a correctly completed declaration has been submitted. **Non-completion will result in delay.** The manufacturer can refuse to accept any equipment without a declaration.

A separate declaration has to be completed for every single component.

This declaration may be completed and signed only by authorised and qualified staff.

Customer/Dep./Institute: _____ _____ Address _____ _____ Person to contact: _____ Phone: _____ Fax: _____ Order number of customer: _____	Reason for returning <input checked="" type="checkbox"/> applicable please mark <input type="checkbox"/> repair <input type="checkbox"/> chargeable <input type="checkbox"/> warranty <input type="checkbox"/> Austausch <input type="checkbox"/> chargeable <input type="checkbox"/> warranty <input type="checkbox"/> DKD-calibration <input type="checkbox"/> Factory calibration restoring goods because of following reason: <input type="checkbox"/> rent/loan <input type="checkbox"/> for credit <input type="checkbox"/> against exchange <input type="checkbox"/> exchange already received/arranged
---	--

A. Description of the equipment (machine or component)	Ancillary equipment
Type: _____	_____
Part number: _____	_____
Serial number: _____	_____
Type of oil used: _____	_____

B. Condition of the equipment							
	No	Yes	No	Contamination:	No	Yes	
1. Has the equipment been used	<input type="checkbox"/>	<input type="checkbox"/>	<input type="checkbox"/>	toxic	<input type="checkbox"/>	<input type="checkbox"/>	
2. Drained (Product/service fluid)	<input type="checkbox"/>	<input type="checkbox"/>	<input type="checkbox"/>	corrosive	<input type="checkbox"/>	<input type="checkbox"/>	
3. All openings sealed airtight	<input type="checkbox"/>	<input type="checkbox"/>	<input type="checkbox"/>	microbiological	<input type="checkbox"/>	<input type="checkbox"/>	
4. Purged	<input type="checkbox"/>	<input type="checkbox"/>	<input type="checkbox"/>	explosive	<input type="checkbox"/>	<input type="checkbox"/>	
If yes which cleaning agent:	_____			radioactive	<input type="checkbox"/>	<input type="checkbox"/>	
and which method of cleaning:	_____			other harmful substances	<input type="checkbox"/>	<input type="checkbox"/>	

C. Description of processed substances (Please fill in absolutely)			
1. What substances have come into contact with the equipment:			
Trade name and / or chemical term of service fluids and substances processed, properties of the substances; According to safety data sheet (e.g. toxic, inflammable, corrosive, radioactive)			
Tradenname:	Chemical name:		Residues:
a) _____	_____		<input type="checkbox"/> Yes <input type="checkbox"/> No
b) _____	_____		<input type="checkbox"/> Yes <input type="checkbox"/> No
c) _____	_____		<input type="checkbox"/> Yes <input type="checkbox"/> No
d) _____	_____		<input type="checkbox"/> Yes <input type="checkbox"/> No
2. Are these substances harmful?	Yes	No	
	<input type="checkbox"/>	<input type="checkbox"/>	
3. Dangerous decomposition products when thermally loaded	Yes	No	
Which:	<input type="checkbox"/>	<input type="checkbox"/>	

Components contaminated by microbiological, explosive or radioactive products will not be accepted without written evidence of decontamination.

D. Legally binding declaration
I / we hereby declare that the information supplied on this form is accurate and sufficient to judge any contamination level.

Name of authorised person (block letters): _____	
date _____ signatur of authorised person _____	firm stamp

Sales and Service Net Worldwide

Germany

Leybold Vacuum GmbH
Bonner Strasse 498
D-50968 Cologne
Phone: +49-221-347 1234
Fax: +49-221-347 1245
sales@leybold.com

Leybold Vacuum GmbH
Sales Area North/East
Branch office Berlin
Buschkrugallee 33
1. Obergeschoss
D-12359 Berlin
Phone: +49-30-435 609 0
Fax: +49-30-435 609 10
sales.berlin@leybold.com

Leybold Vacuum GmbH
Sales Area South/Southwest
Branch office Munich
Karl-Hammerschmidt-Strasse 38
D-85609 Aschheim/Dornach
Phone: +49-89-357 33 90
Fax: +49-89-357 33 933
sales.muenchen@leybold.com
service.muenchen@leybold.com

Leybold Vacuum GmbH
Sales Area West
Branch office Cologne
Emil-Hoffmann-Straße 43
D-50996 Cologne-Suerth
Phone: +49-221-347 1270
Fax: +49-221-347 1291
sales.koeln@leybold.com

Leybold Vacuum GmbH
Service Center
Emil-Hoffmann-Straße 43
D-50996 Cologne-Suerth
Phone: +49-221-347 1439
Fax: +49-221-347 1945
service@leybold.com

Leybold Vacuum GmbH
Mobile after sales service
Emil-Hoffmann-Straße 43
D-50996 Cologne-Suerth
Phone: +49-221-347 1765
Fax: +49-221-347 1944
kundendienst@leybold.com

Leybold Vacuum
Dresden GmbH
Zur Wetterwarte 50, Haus 304
D-01109 Dresden
Service:
Phone: +49-351-88 55 00
Fax: +49-351-88 55 041
info@leybold-dresden.de
www.leybold-dresden.de

Europe

Belgium
Leybold Vacuum Nederland B.V.
Belgisch bijkantoor
Leuvensesteenweg 542-9A
B-1930 Zaventem
Sales:
Phone: +32-2-711 00 83
Fax: +32-2-720 83 38
sales.belgium@leybold.com
Service:
Phone: +32-2-711 00 82
Fax: +32-2-720 83 38
service.belgium@leybold.com

France
Leybold Vacuum France S.A.
7, Avenue du Québec
Z.A. de Courtaboeuf, B.P. 42
F-91942 Courtaboeuf Cedex
Sales and Service:
Phone: +33-1-69 82 48 00
Fax: +33-1-69 07 57 38
leybold-vacuum@leybold.fr

Leybold Vacuum France S.A.
Valence Factory
640, rue A. Bergès - B.P. 107
F-26501 Bourg-lès-Valence Cedex
Phone: +33-4-75 82 33 00
Fax: +33-4-75 82 92 69
marketing.valence@leybold.fr

Great Britain
Leybold Vacuum UK Ltd.
Waterside Way, Plough Lane
GB-London SW17 0HB
Sales:
Phone: +44-20-8971 7000
Fax: +44-20-8971 7001
sales@leybold.co.uk
Service:
Phone: +44-20-8971 7030
Fax: +44-20-8971 7003
service@leybold.co.uk

Italy
Leybold Vacuum Italia S.p.A.
8, Via Trasimeno
I-20128 Milano
Sales:
Phone: +39-02-27 22 31
Fax: +39-02-27 20 96 41
sales@leybold.it

Service:
Phone: +39-02-27 22 31
Fax: +39-02-27 20 96 41
service@leybold.it

Field Service Base
Z.I. Le Capanne
I-05021 Acquasparta (TR)
Phone: +39-0744-93 03 93
Fax: +39-0744-94 42 87
service@leybold.it

Netherlands
Leybold Vacuum Nederland B.V.
Computerweg 7
NL-3542 DP Utrecht
Sales and Service:
Phone: +31-346-58 39 99
Fax: +31-346-58 39 90
sales.netherlands@leybold.com
service.netherlands@leybold.com

Spain
Leybold Vacuum España S.A.
C/. Huelva, 7
E-08940 Cornella de Llobregat
(Barcelona)
Sales:
Phone: +34-93-666 46 16
Fax: +34-93-666 43 70
sales.spain@leybold.com
Service:
Phone: +34-93-666 49 51
Fax: +34-93-685 40 10

Sweden
Leybold Vacuum Scandinavia AB
Box 9084
SE-40092 Göteborg
Sales and Service:
Phone: +46-31-68 84 70
Fax: +46-31-68 39 39
info@leybold.se
Visiting/delivery address:
Datavägen 57B
SE-43632 Askim

Switzerland
Leybold Vacuum Schweiz AG
Leutschenbachstrasse 55
CH-8050 Zürich
Sales:
Phone: +41-1-308 40 50
Fax: +41-1-302 43 73
sales@leybold.ch
Service:
Phone: +41-1-308 40 62
Fax: +41-1-308 40 60

America

USA
Leybold Vacuum USA Inc.
5700 Mellon Road
Export, PA 15632
info@leyboldvacuum.com
Sales:
Eastern & Central time zones
Phone: +1-724-327-5700
Fax: +1-724-733-1217
Pacific, Mountain,
Alaskan & Hawaiian time zones
Phone: +1-480-752-9191
Fax: +1-480-752-9494
Service:
Phone: +1-724-327-5700
Fax: +1-724-733-3799

Asia

P.R. China
Leybold Vacuum (Tianjin)
International Trade Co., Ltd.
Beichen Economic Development
Area (BEDA), Shuanghai Road
Tianjin 300400, China
Sales and Service:
Phone: +86-22-2697 0808
Fax: +86-22-2697 4061
Fax: +86-22-2697 2017
leybold@leybold.com.cn

Leybold Vacuum (Tianjin)
Equipment Manufacturing Co., Ltd.
Beichen Economic Development
Area (BEDA), Shuanghai Road
Tianjin 300400, China
Phone: +86-22-2697 0808
Fax: +86-22-2697 4061
Fax: +86-22-2697 2017
leybold@leybold.com.cn

Leybold Vacuum (Tianjin)
International Trade Co., Ltd.
Beijing Branch:
1-908, Beijing Landmark Towers
8 North Dongsanhuan Road
Chaoyang District
Beijing 100004, China
Sales and Service:
Phone: +86-21-5064-4666
Fax: +86-21-5064-4668
leybold_sh@leybold.com.cn

Leybold Vacuum (Tianjin)
International Trade Co., Ltd.
Shanghai Branch:
Add: No. 33, 76 Futedong San
Rd., Waigaoqiao FTZ.,
Shanghai 200131, China
Sales and Service:
Phone: +86-21-5064-4666
Fax: +86-21-5064-4668
leybold_sh@leybold.com.cn

Leybold Vacuum (Tianjin)
Guangzhou Branch:
Add: G/F,#301 Building,
110 Dongguangzhuang Rd.
Tianhe District,
Guangzhou 510610, China
Sales:
Phone: +86-20-8723-7873
Phone: +86-20-8723-7597
Fax: +86-20-8723-7875
leybold_gz@leybold.com.cn

India
Leybold Vacuum India Pte Ltd.
A-125 Road No. 30
MIDC Wagale Industrial Estate
Thane(W) - 400 604 Maharashtra
India
Sales and Service:
Phone: +91-22-2581 2929
Fax: +91-22-2581 2626
itv2004@yahoo.com

Japan
Leybold Vacuum
Japan Co., Ltd.
Head Office
Tobu A.K. Bldg. 4th Floor
23-3, Shin-Yokohama
3-chome
Kohoku-ku, Yokohama-shi
Kanagawa-ken 222-0033
Sales:
Phone: +81-45-4713330
Fax: +81-45-4713323

Leybold Vacuum
Japan Co., Ltd.
Osaka Branch Office
MURATA Bldg. 7F
2-7-53, Nishi-Miyahara
Yodogawa-ku
Osaka-shi 532-0004
Sales:
Phone: +81-6-6393-5211
Fax: +81-6-6393-5215

Leybold Vacuum
Japan Co., Ltd.
Tsukuba Technical S.C.
Tsukuba Minami Daiichi
Kogyo Danchi
21, Kasumi-no-Sato,
Ami-machi, Inashiki-gun
Ibaraki-ken, 300-0315
Service:
Phone: +81-298-89-2841
Fax: +81-298-89-2838

Korea
Leybold Vacuum Korea Ltd.
#761-4, Yulkeum-ri,
SungHwan-eup, Chonan
Choongchung-Namdo,
330-807, Korea
Sales:
Phone: +82-41-580-4421
Fax: +82-41-588-3737
Service:
Phone: +82-41-580-4419
Fax: +82-41-588-0166

Singapore
Leybold Vacuum
Singapore Pte Ltd.
No.1, International
Business Park,
B1-20B, The Synergy
Singapore 609917
Sales and Service:
Phone: +65-66652910
Fax: +65-65668202
vacuum@leyboldvac.com.sg

Taiwan
Leybold Vacuum Taiwan Ltd.
No 416-1, Sec. 3
Chung-Hsin Rd., Chu-Tung
Hsin-Chu, Taiwan, R.O.C.
Sales and Service:
Phone: +886-3-5833988
Fax: +886-3-5833999

Hotline

Sales: +49-221-347 1234

Service: +49-221-347 1765

sales@leybold.com
service@leybold.com

Leybold Vacuum GmbH
Bonner Strasse 498
D-50968 Cologne
Phone: +49-221 347-0
Fax: +49-221 347-1250
info@leybold.com

**Leybold**
vacuum

www.leybold.com