

# ***SHI CRYOCOOLER SPECIFICATION***

***MODEL: SRP-082B-F70H***  
***(Preliminary)***

***Cold Head Unit: RP-082B***  
***Compressor Unit: F-70H***

***Cryogenics Division***  
***Precision Equipment Group***  
***Sumitomo Heavy Industries, Ltd.***

# **SHI CRYOCOOLER SPECIFICATION**

**MODEL: SRP-082B-F70H**

**Cold Head Unit: RP-082B  
Compressor Unit: F-70H  
(Preliminary)**

**Cryogenics Division  
Precision Equipment Group  
Sumitomo Heavy Industries, Ltd.**

<i>A</i>	<i>2009 / 5 / 15</i>	<i>Original</i>	<i>M. Saito</i>	<i>Y. Ikeya</i>	<i>K. Ito</i>
<b>Rev.</b>	<b>Date</b>	<b>Description</b>	<b>Prepared</b>	<b>Checked</b>	<b>Approved</b>

# CRYOCOOLER SPECIFICATION

## Cryocooler MODEL

Cold Head Unit Model  
Compressor Unit Model

## SRP-082B-F70H

RP-082B  
F-70H

Regulation

UL  
CE

## New Condition

### 1. Cold Head Unit (Model: RP-082B)

Refrigeration Cycle

Pulse Tube  
(2-Stage)

Site Condition

Indoor

Cooling Capacity\*  
(Vertical Position)

1st	40 W at 45 K	(50 / 60Hz)
2nd	1.0 W at 4.2 K	(50 / 60Hz)

\*2nd stage is covered with shield. Additionally, 1st and 2nd stages are covered with Super Insulation (10 layers).  
\*in Vacuum. The cooling capacity will be affected by the quality of insulations.

Lowest Temperature

< 3.0 K -- for reference only

Displacement

1st	+/- 7 $\mu$ m	-- for reference only
2nd	+/- 9 $\mu$ m	-- for reference only

Cool Down Time\*  
(300K to 4.2K, 2nd Stage)

< 80 min. (50 / 60Hz)  
-- for reference only

\*without heat load and weight

Cooling Capacity Degradation  
(10,000hr)

< 10% -- for reference only

Orientation	Vertical only	
Ambient Temperature Range	5 to 35 deg.C (28 to 35 deg.C with cooling capacity loss max. 10%)	
Dimension	H: 581 x W: 190 x L: 347 mm -- approx.	
Weight	26 kg	-- approx.
Maintenance	Shown in Table 1	

**Table 1 MAINTENANCE SCHEDULE  
FOR THE COLD HEAD UNIT**

Maintenance	Frequency	Remark
Replace the Inside sliding parts.	Every 20,000 Hrs.	<b>“SHI maintenance” Return the Cold Head Unit to SHI, Ltd.</b>
He Gas purging inside the coldhead		
Replace the Filter Unit		<b>“USER maintenance”</b>

**Notes;**

*Users cannot do these maintenance works.*

*Return the Cold Head Unit and Filter Unit to SHI, Ltd.*

*Although He Gas cleaning work on site is possible (SHI worker proceeds), it is necessary to return the cold stage to room temperature before He gas cleaning.*

**Notes;**

*The cooling capacity depends on the ambient temperature.*

*The room should be provided to install the Cold Head Unit.*

## 2. Compressor Unit (Model: F-70H)

Cooling system	Water Cooled		
Site Condition	Indoor		
Electrical Requirement			
Power Line Voltage	3 phase (3W+PE),		
50Hz	AC 380, 400, 415 V (+/- 10%)		
60Hz	AC 480 (+/- 10%)		
Power Requirement			
Minimum	11 kVA		
Recommended	14 kVA		
Power Consumption	Steady	Maximum	
50Hz	7.2 kW	8.5 kW	-- approx.
60Hz	8.5 kW	9.8 kW	-- approx.
Operating Current			
Maximum	15A		-- approx.
Built-in Circuit Breaker Setting	16A		
Ambient Temperature Range	5 to 35 deg.C (28 to 35 deg.C with cooling capacity loss max. 10%)		
Cooling Water Requirement*			
Inlet Temperature	5 to 25 deg.C		
Cooling Water Flow rate	6.8 – 9.0 liter / min.		
Quality Requirement	Refer to the ANNEX.		
*See the ANNEX. for more detail.			

Noise Level (1m distance)

Compressor Unit Only      Max. 70 dBA      -- approx.

\*Noise level of the whole equipment may exceed 70dBA depending on the environment it is used in.

Dimension

H: 577 x W: 443 x L: 493 mm\* -- approx.

\* H: Without Removable Eyebolts.

\* W: With Cover.

\* L: Without Front Cover.

Weight

100 kg      -- approx.

Required Space

Front Side

600mm for access to electrical, water and gas connections.

Left Side\*

600mm for maintenance of the adsorber

\*when facing the front

Maintenance

Shown in Table 2

**Table 2 MAINTENANCE SCHEDULE FOR THE COMPRESSOR UNIT**

Maintenance	Frequency	Remark
Replace the Adsorber	Every 30,000 Hrs.	"USER maintenance"
Charge/Purge the Helium Gas	As required	"USER maintenance" Purity of 99.999% up
Replace the Fuse(s)	As required	"USER maintenance"
Cleaning the Water Line	As required	"USER maintenance" Depending on the water conditions

**Notes**

- While carrying the compressor unit, do not tilt it by more than 30 degrees.*
- While setting the compressor unit, do not tilt it by more than 5 degrees.*

### 3. Accessories (Standard)

Flexible Gas Line	Standard	
	25A x 20 m (F-F) (Supply)	x 1
	25A x 20 m (F-F) (Return)	x 1
Filter Unit	Filter+20A x 1m	
	Flexible Gas line	x 1
Cold Head Power Cable	20 m	x 1
Input Power Cable	2.0 m	x 1
Hose Nipple	OD:12.7mm x PT1/2(Female)	x 2
Tool Kit	Gas Charge Valve	x 1
	Open end wrench (26mm)	x 1
	Open end wrench (29mm)	x 1
	Quick Wrench	x 1
Manual	Operation Manual	x 1
	Technical Instruction for Cold Head Unit	x 1
	Technical Instruction for Compressor Unit	x 1

#### Notes

·Cold Head Power Cable is available minimum 6 m.

#### **4. Annex.**

- 1) System Configuration
- 2) Cold Head DWG.
- 3) Compressor Unit DWG.
- 4) Compressor Wiring Schematic
- 5) Cooling Water Requirement
- 6) Flexible Gas Line DWG. (Standard)
- 7) Filter Unit DWG.
- 8) Cold Head Power Cable DWG. (Standard)
- 9) Input Power Cable DWG. (Standard)
- 10) Hose Nipple DWG.
- 11) Gas Charge Valve DWG.

#### **5. Scope of Supply**

The followings are included.

- 1) Cold Head Unit
- 2) Compressor Unit
- 3) Input Power Cable
- 4) Flexible Gas Lines (Supply and Return)
- 5) Filter Unit
- 6) Cold Head Power Cable
- 7) Hose Nipple
- 8) Tool Kit
- 9) Operation Manual

The followings are not included in this spec.

- 1) Thermometer
- 2) Temperature indicator
- 3) O-ring between Cold Head Unit and Vacuum Chamber
- 4) Vacuum Chamber
- 5) Vacuum Pump
- 6) Bolts



## **6. Warranty <Sale and Purchase of New Machines>**

### **Warranty Period**

Warranty period for the newly supplied Machines shall be eighteen (18) months from the date of shipment of the Machines from Sumitomo's works or twelve (12) months from the date of the operation and use of the Machines by the customer, whichever comes earlier.

### **Warranty Conditions**

During the warranty period, should any defects are found in the Machines irrespective of the fact that the Machines are properly installed, connected and maintained in conformity to the instructions manuals and are properly operated under the conditions as instructed in the specifications and operation manuals, Sumitomo will, at its discretion, repair or replace free of charge the Machines except for the cases which fall under the category of the warranty exception as enumerated below.

Provided, however, that in the event the Machines are connected with the customer's other equipment, the costs for the removal from and re-installation of the Machines to such equipment, and other costs incidental to such work, including transportation charges thereto and so on shall be borne by the customer.

The scope of Sumitomo's liability pursuant to the warranty shall be limited to the repair or replacement of the Machines.

Sumitomo shall not compensate any expenses, fees or charges for repair or replacement of the Machines or parts therefor incurred by the customer or third parties other than Sumitomo or Sumitomo's authorized servicing companies without prior written consent of Sumitomo or Sumitomo's authorized servicing companies.

SUMITOMO MAKES NO WARRANTIES OF MERCHANTABILITY OR FITNESS FOR ANY PARTICULAR USE AND PURPOSE OF THE CUSTOMER, NOR ARE ANY OTHER WARRANTIES MADE, EXPRESS OR IMPLIED, UNLESS OTHERWISE SPECIFICALLY AGREED IN WRITING.

### **Warranty Exception**

The warranty shall not apply to the following cases.

1. Any defects caused by improper installation of the Machines or improper connection with other related equipment by the customer or third party other than Sumitomo or Sumitomo's authorized servicing companies.
2. Any defects caused by insufficient maintenance or improper handling of the Machines by the customers.
3. Any defects caused by the operation of the Machines outside the specifications or operation and use conditions beyond Sumitomo's expectation by the customer.
4. Any defects caused by the modification or alteration to the Machines by the customer or third parties other than Sumitomo or Sumitomo's authorized servicing companies.
5. Any defects of the Machines caused by the parts supplied or specified by the customer.
6. Any damage caused by Force Majeure, such as earthquakes, fires, floods, salt damage, gas damage, thunder and other causes beyond the control of Sumitomo.
7. Any other defects caused by the events not attributable to Sumitomo.

### **Limitation of Damages**

Any damages, if any, to be compensated to the customer due to the defects of the Machines attributable to Sumitomo shall be limited to the direct damages actually incurred by the customer and shall not exceed the contract price of the Machines.

### **Indemnification**

Sumitomo shall not be responsible for the following damage irrespective of the causes or reasons for the claims made by the customer.

1. Any losses of profits and operation opportunity and other consequential or indirect loss or damage of any kind incurred by the customer in connection with the Machines.
2. Any damage to the Machines caused by any special circumstance on the part of the customer which is attributable to the customer irrespective of whether such damage is foreseeable or not by Sumitomo.
3. Any damage incurred by the customer resulting from the damages claimed by third party for which Sumitomo is not responsible.
4. Any damage incurred by the customer due to collection and improvement of the same kind of machines or similar to the Machines caused by recall of those machines.

### **Maintenance**

The maintenance work of the Machines shall be recommendable to be performed at an interval which is described in the above sentence.

### **Parts Supply**

Unless otherwise specified in the contract documents, Sumitomo shall keep any parts for the Machines for a period of seven (7) years from the delivery date of the Machines to the customer.

---

**Notes; Specifications subject to change or delete without notice.**

**Sumitomo Heavy Industries, Ltd.**

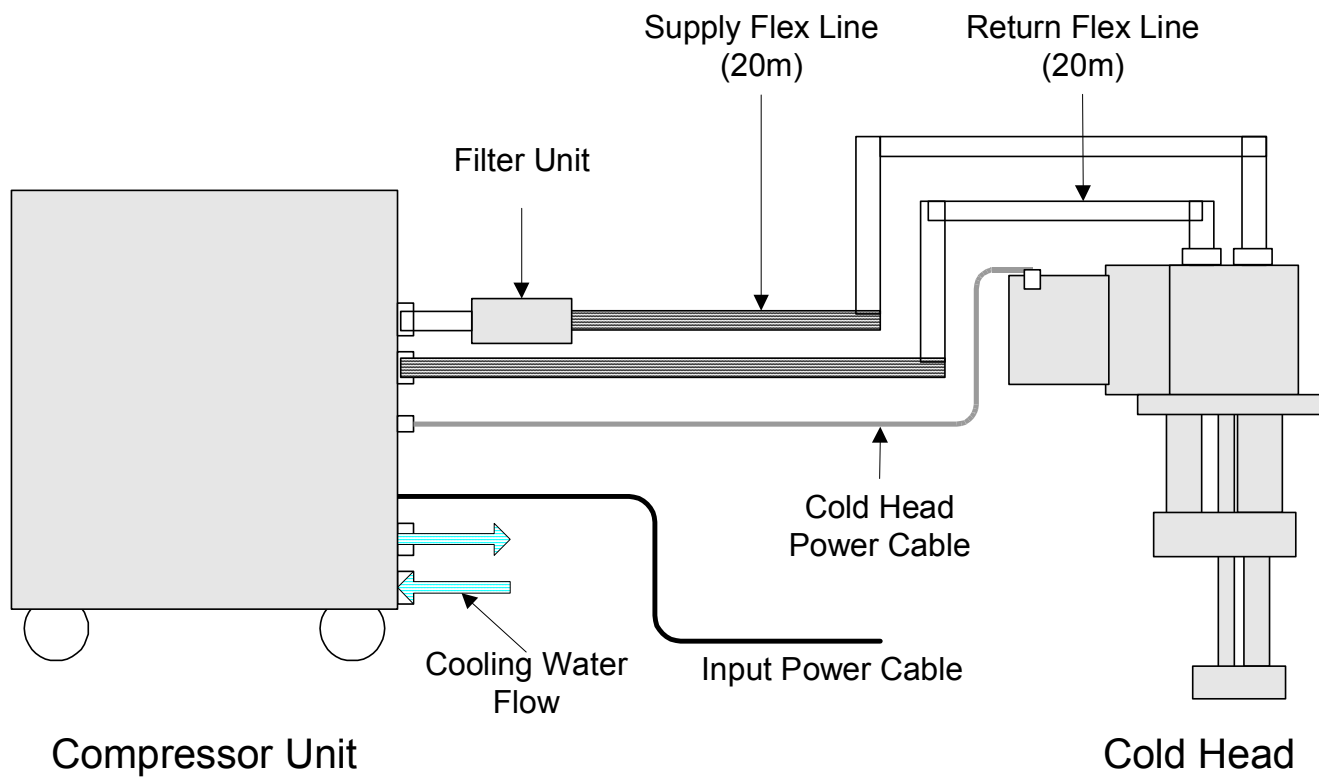

**SYSTEM CONFIGURATION**

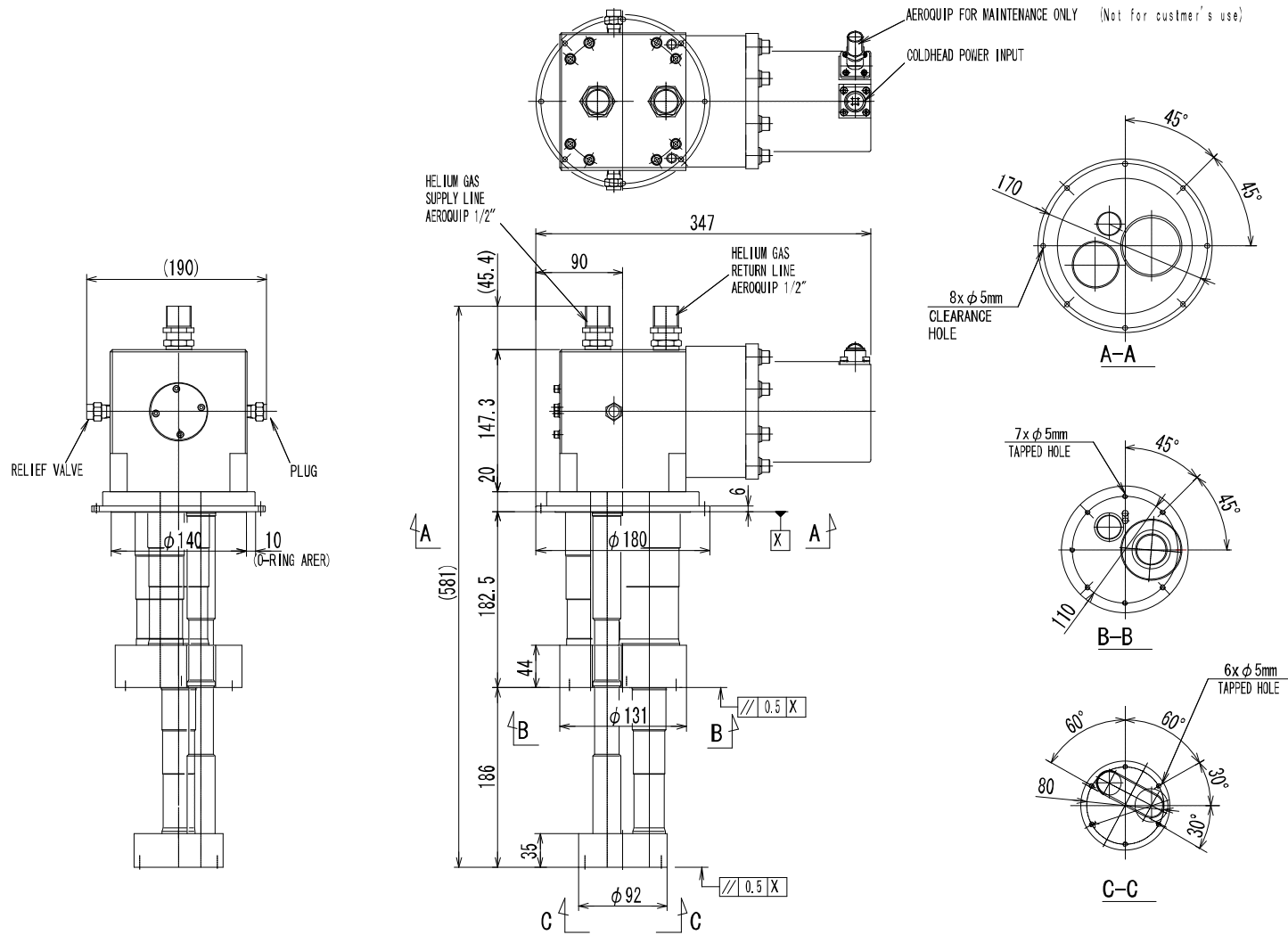

# COLD HEAD UNIT



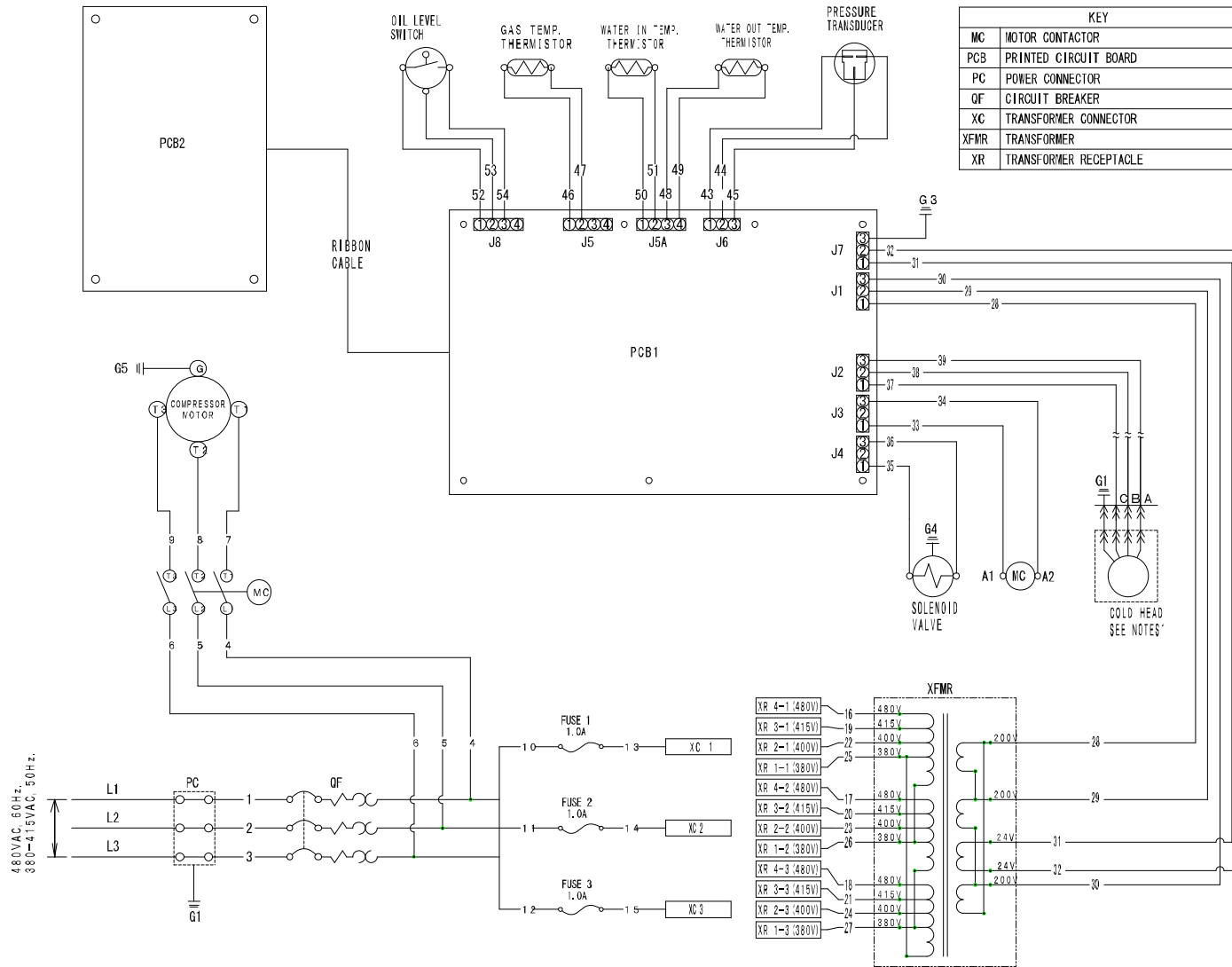

KEY	
MC	MOTOR CONTACTOR
PCB	PRINTED CIRCUIT BOARD
PC	POWER CONNECTOR
QF	CIRCUIT BREAKER
XC	TRANSFORMER CONNECTOR
XFMR	TRANSFORMER
XR	TRANSFORMER RECEPTACLE

NOTES:  
 1. 200V-50/60Hz  
 (FULL LOAD AND STARTING CURR.  
 APPROX. 0.25A)

XE07M0369AD

# COMPRESSOR WIRING SCHEMATIC

## COOLING WATER QUALITY REQUIREMENT

Water supplied for cooling the compressor should be filtered through a 300-micron screen and meet the following quality limits;

**Table COOLING WATER QUALITY REQUIREMENT**

ITEM	Initial Values for non-Replenished (close) System	Values for Continuously Replenished (open) System
Suspended solids, $\mu$ g/L	<250	<250
Particle size, $\mu$ m	<300	<300
pH(25deg.C)	6.5 to 8.0	6.0 to 8.0
Alkalinity (ppm)	100 max.	50 max.
Hardness (ppm)	200 max.	50 max.
Chloride (ppm)	200 max.	50 max.
Sulfate (ppm)	200 max.	50 max.
Iron (ppm)	1.0 max.	0.30 max.
Sulfur ion	None detected	None detected
Ammonium ion (ppm)	1.0 max.	0.20 max.
Silica (ppm)	50 max.	30 max.

SUPPLY FLEXILINE

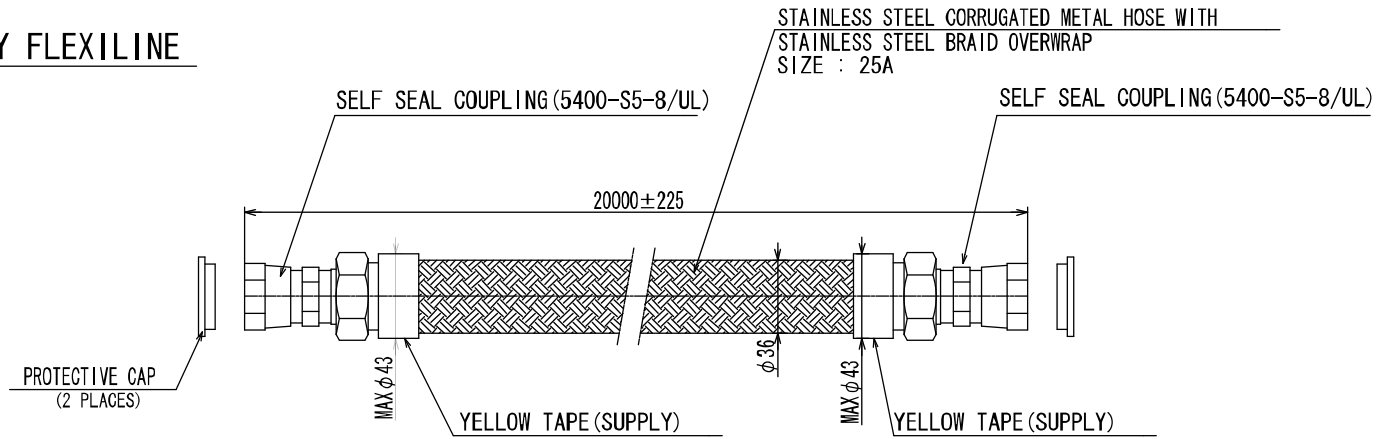

RETURN FLEXILINE

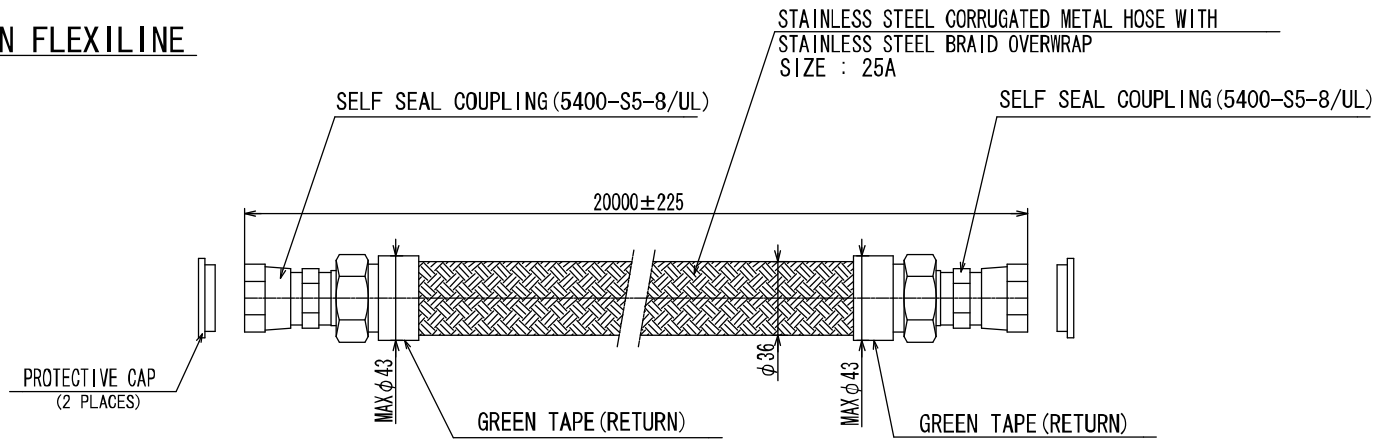

XRW25Z0030AQ

**25A x 20m (F-F) FLEXIBLE GAS LINE**

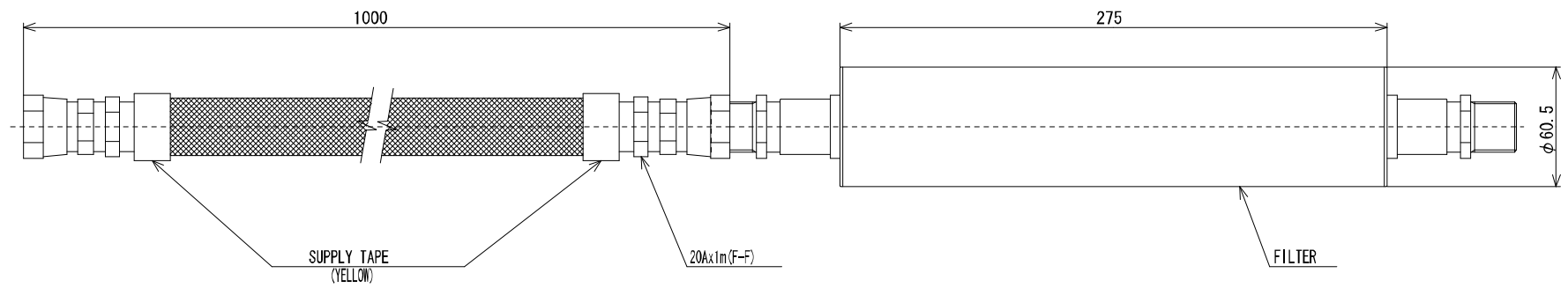

XRP20Y0042A0

## FILTER UNIT



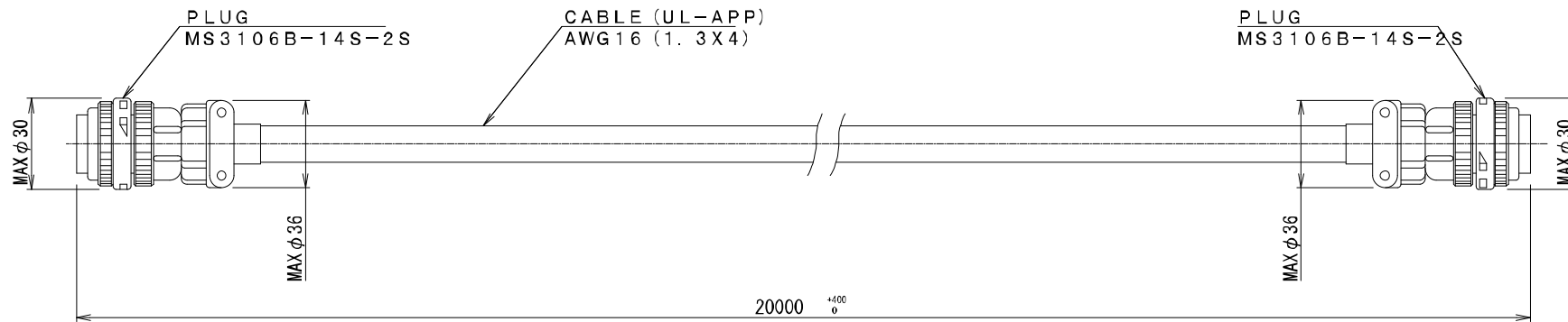

XRZ31Z0061A0

## COLD HEAD POWER CABLE (20m)

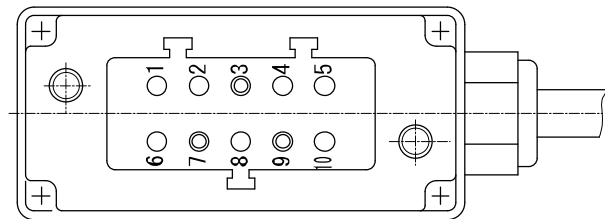
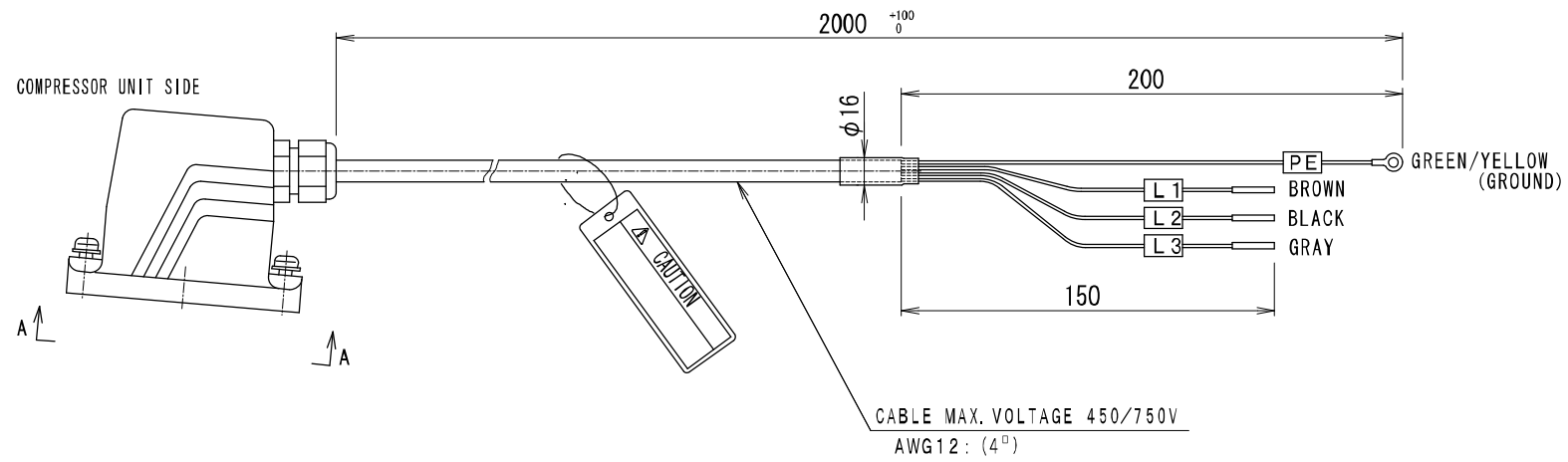

VIEW A-A

NOTE

1. PART TO BE BAGGED OR BOXED AND SEALED FROM DIRT AND MOISTURE.

XRE07W0366BQ

## INPUT POWER CABLE (2m)

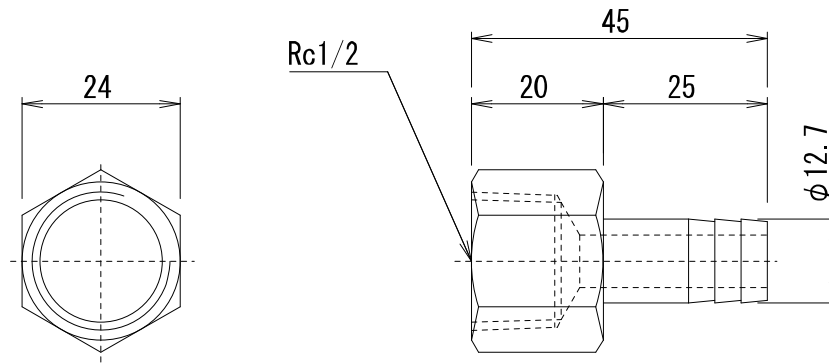

XRP85Z0167AQ

**Material : Brass**

**HOSE NIPPLE 12.7 x 1 / 2**

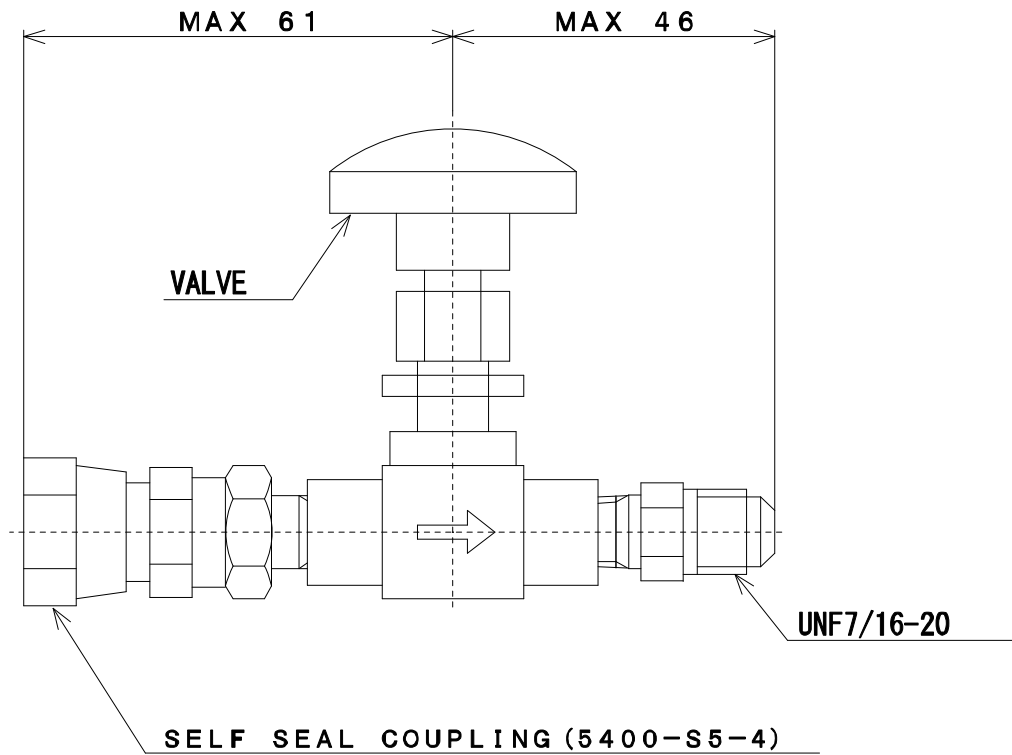

**GAS CHARGE VALVE**