



## HiCube 80 Eco

Turbo pumping station

# Operating Instructions

# Table of contents

<b>1</b>	<b>About this manual</b> .....	<b>3</b>
	1.1 Validity .....	3
	1.2 Conventions .....	3
<b>2</b>	<b>Safety</b> .....	<b>5</b>
	2.1 Safety precautions .....	5
	2.2 Protective equipment .....	6
	2.3 Proper use .....	7
	2.4 Improper use .....	7
<b>3</b>	<b>Transport and storage</b> .....	<b>8</b>
	3.1 Transport .....	8
	3.2 Transportation lock .....	8
	3.3 Storage .....	8
<b>4</b>	<b>Product description</b> .....	<b>9</b>
	4.1 Product identification .....	9
	4.2 Function .....	10
	4.3 Range of application .....	11
<b>5</b>	<b>Installation</b> .....	<b>12</b>
	5.1 Set-up .....	12
	5.2 Preparatory work .....	12
	5.3 Connecting the high vacuum side .....	12
	5.4 Connecting the exhaust side .....	14
	5.5 Connecting accessories .....	15
	5.6 Transportation lock .....	16
	5.7 Voltage range of the backing pump .....	16
	5.8 Connecting to the mains power supply .....	17
<b>6</b>	<b>Operation</b> .....	<b>18</b>
	6.1 Commissioning .....	18
	6.2 Operation modes .....	18
	6.3 Function description .....	18
	6.4 Operation with gas ballast valve .....	20
	6.5 Monitoring of the operation conditions .....	20
	6.6 Switching off and venting .....	21
<b>7</b>	<b>Maintenance / replacement</b> .....	<b>22</b>
	7.1 Maintenance intervals and responsibilities .....	22
	7.2 Removal of components for their maintenance .....	22
<b>8</b>	<b>Decommissioning</b> .....	<b>25</b>
	8.1 Shutting down for longer periods .....	25
	8.2 Re-starting .....	25
	8.3 Disposal .....	25
<b>9</b>	<b>Malfunctions</b> .....	<b>26</b>
	9.1 Rectifying malfunctions .....	26
<b>10</b>	<b>Service</b> .....	<b>27</b>
<b>11</b>	<b>Spare parts HiCube 80 Eco</b> .....	<b>28</b>
<b>12</b>	<b>Accessories</b> .....	<b>28</b>
<b>13</b>	<b>Technical data and dimensions</b> .....	<b>29</b>
	13.1 General .....	29
	13.2 Technical data .....	29
	13.3 Dimensions .....	30
	<b>Declaration of conformity</b> .....	<b>31</b>

# 1 About this manual

## 1.1 Validity

This operating manual is for customers of Pfeiffer Vacuum. It describes the functioning of the designated product and provides the most important information for safe use of the unit. The description follows applicable EU guidelines. All information provided in this operating manual refers to the current state of the product's development. The documentation remains valid as long as the customer does not make any changes to the product.

Up-to-date operating instructions can also be downloaded from [www.pfeiffer-vacuum.com](http://www.pfeiffer-vacuum.com).

### Applicable documents

HiCube 80 Eco	Operating instructions
Declaration of Conformity	Part of this document
Operating instructions for components	see product description*

\*also available via [www.pfeiffer-vacuum.com](http://www.pfeiffer-vacuum.com)

## 1.2 Conventions

### Safety instructions

The safety instructions in Pfeiffer Vacuum operating instructions are the result of risk evaluations and hazard analyses and are oriented on international certification standards as specified by UL, CSA, ANSI Z-535, SEMI S1, ISO 3864 and DIN 4844. In this document, the following hazard levels and information are considered:

<b>DANGER</b>
<p><b>Imminent danger</b> Indicates an imminent hazardous situation that will result in death or serious injury.</p>
<b>WARNING</b>
<p><b>Possibly imminent danger</b> Indicates an imminent hazardous situation that can result in death or serious injury.</p>
<b>CAUTION</b>
<p><b>Possibly imminent danger</b> Indicates an imminent hazardous situation that can result in minor or moderate injury.</p>
<b>NOTICE</b>
<p><b>Command or note</b> Command to perform an action or information about properties, the disregarding of which may result in damage to the product.</p>

## Pictographs



Prohibition of an action or activity in connection with a source of danger, the disregarding of which may result in serious accidents



Warning of a displayed source of danger in connection with operation of the unit or equipment



Command to perform an action or task associated with a source of danger, the disregarding of which may result in serious accidents



Important information about the product or this document

## Instructions in the text

→ Work instruction: here you have to do something.

## Abbreviations

<b>DCU:</b>	Display Control Unit
<b>HPU:</b>	Handheld Programming Unit
<b>TC:</b>	Electronic drive unit for turbopump
<b>TPS:</b>	Mains pack

## Symbols used

The following symbols are used consistently throughout the diagrams:

- Ⓜ High vacuum flange
- Ⓥ Fore-vacuum connection
- Ⓣ Electric connection
- Ⓚ Air cooling unit
- Ⓛ Venting connection
- Ⓢ Sealing gas connection
- Ⓛ Exhaust connection

## 2 Safety

### 2.1 Safety precautions



#### Duty to inform

Each person involved in the installation, operation or maintenance of the vacuum pump must read and observe the safety-related parts of these operating instructions.

→ The operator is obligated to make operating personnel aware of dangers originating from the vacuum pump, the pumped medium and the entire system.



#### Installation and operation of accessories

Pfeiffer Vacuum pumps can be equipped with a series of adapted accessories. The installation, operation and maintenance of connected devices are described in detail in the operating instructions of the individual components.

→ For information on order numbers of components, see "Accessories".

→ Use original accessory parts only.



#### NOTICE

#### Checking the safety system against excess rotation speed

To provide the functioning of the integrated safety system for avoiding excess rotation speed, the pump must run-up from the standstill at least once a year.

→ Switch off the pump and await the complete standstill (rotation speed = 0 Hz).

→ Run-up the pump according to this operating instructions.



#### WARNING

#### Danger of unsafe electrical installation

Safe operation after installation is the responsibility of the operator.

→ Do not independently modify or change the pump and electrical equipment.

→ Make sure that the system is integrated in an emergency off safety circuit.

→ Consult Pfeiffer Vacuum for special requirements.



#### WARNING

#### Danger due to lack of power disconnection device

Pump and electronic drive unit are not equipped with a power disconnection device. Installation of a user-supplied power disconnection device in accordance with SEMI-S2.

→ Fit a circuit breaker with an interruption rating of min. 10,000 A.



#### WARNING

#### Danger of electric shock

In case of defect, the parts connected to the mains supply are under voltage.

→ Always keep the mains connection freely accessible so you can disconnect it at any time.

- Do not expose any body parts to the vacuum.
- Observe all safety and accident prevention regulations.
- Regularly check the proper observance of all safety measures.
- Always ensure a safe connection to the protective earthing conductor (PE, protection class I).
- Do not loosen any plug connection during operations.
- Wait for the rotor to reach standstill before performing work on the high vacuum flange.
- Keep leads and cables well away from hot surfaces (> 70 °C).
- Never fill or operate turbopump with cleaning agent.
- Do not operate the turbopump with open high vacuum flange.

- Do not carry out any unauthorised modifications or conversions to the pumps.
- The unit has been accredited with protection class IP 20. Take necessary measures when installing into ambient conditions, which afford other protection classes.
- Note the shipping instructions, when returning the unit.

## 2.2 Protective equipment

Determined situations concerning the handling of vacuum pumps require wearing of personal protective equipment. The owner, respectively the employer are obligated to provide adequate equipment to any operating persons.



### DANGER

#### Danger to health by hazardous substances during maintenance or installation

Depending on the process vacuum pumps, components or operating fluids can be contaminated by toxic, reactive or radioactive substances.

→ Wear adequate protective equipment during maintenance and repairs or in case of reinstallation.

### WARNING

#### Risk of injury through falling objects

When transporting vacuum pumps by hand, there is a danger through loads slipping and falling down.

- Carry small and mid-size vacuum pumps two-handed.
- Carry vacuum pumps > 20 kg by a suitable lifting device.
- Wear safety shoes with steel toe cap according to directive EN 347.

### CAUTION

#### Risk of injury through hot surfaces

Vacuum pumps can become hot during operation.

- Allow the pump to cool before maintenance and repairs.
- If necessary wear protective gloves according to EN 420.

### CAUTION

#### Risk of injury through sharp edges

Rotor and stator disks of turbopumps have very sharp edges.

- Before any working wait for the complete standstill of the pump.
- Do not reach in the high vacuum flange.
- If necessary wear protective gloves according to EN 420.

## 2.3 Proper use



### NOTICE

#### EC conformity

The manufacturer's declaration of conformity becomes invalid if the operator modifies the original product or installs additional components.

→ Following installation into a plant and before commissioning, the operator must check the entire system for compliance with the valid EU directives and reassess it accordingly.

- Only use the pumping station for creating vacuum.
- Only operate the pumping station as an entire unit.
- Only use the pumping station for evacuation of dry and inert gases; other applications only after consultation with Pfeiffer Vacuum.

## 2.4 Improper use

Improper use will cause all claims for liability and warranties to be forfeited. Improper use is defined as usage for purposes deviating from those mentioned above, especially:

- pumping of corrosive or explosive media
- pumping of condensing vapors
- pumping of liquids
- pumping of dusts
- operation with improper high gas throughput
- operation with improper high fore-vacuum pressures
- operation with improper gas mode
- operation with improper high levels of insulated heat input
- venting with improper high venting rates
- operation of the pumping station to generate pressure
- operation of the devices in areas with ionizing radiation
- use of the devices in systems in which impact-like stress and vibrations or periodically forces affect the devices
- connection to a power supply with earthing of a direct voltage pole
- use of accessories or spare parts, which are not named in this manual

warranty seal

**PFEIFFER**  **VACUUM**

#### Closure seal

The product is sealed at the factory. Damaging or removal of a closure seal leads to the loss of liability and warranty entitlements.

→ Do not open the product within its warranty period!

→ For process-related shorter maintenance intervals please contact the Pfeiffer Vacuum Service.

## 3 Transport and storage

### 3.1 Transport

- Only transport the pumping station by hand.
- Always transport the pumping station uprightly and as even as possible.
- Keep the original protective covers.

### 3.2 Transportation lock

The backing pump of the pumping station HiCube 80 Eco is secured against damage during transport (*see p. 16, chap. 5.6*).

- Follow instructions concerning the installation location!
- Before putting into operation loosen the backing pump's transportation lock device at the installation location.

### 3.3 Storage

- Close the flange openings by using the original protective covers.
- Close further connection ports by using the corresponding protective covers.
- Only store the pumping station indoors at an ambient temperature between -10 °C and +40 °C.
- In rooms with moist or aggressive atmospheres, the pumping station must be airproof shrink-wrapped in a plastic bag together with a bag of dessicant.



## 4 Product description

### 4.1 Product identification

#### Product characteristics



This product has been tested to the requirements of CAN/CSA-C22.2 No. 61010-1, second edition, including Amendment 1, or a later version of the same standard incorporating the same level of testing requirements.

For information about other certifications, if applicable, please see the signet on the product or:

- [www.tuvdotcom.com](http://www.tuvdotcom.com)
- TUVdotCOM-ID 0000021320

Feature	HiCube 80 Eco			Operating instructions
	DN 63 ISO-K	DN 63 CF	DN 40 ISO-KF	
High vacuum flange	Aluminium	Stainless steel	Aluminium	
Flange material	HiPace 80	HiPace 80	HiPace 80	PT 0208 BN
Turbopump	TC 110	TC 110	TC 110	PT 0204 BN
Electronic drive unit	MVP 015-2	MVP 015-2	MVP 015-2	PU 0012 BN
Backig pump	TPS 110	TPS 110	TPS 110	PT 0199 BN
Power supply pack	DCU 002	DCU 002	DCU 002	PT 0250 BN
Display and control unit (option)	Air cooling unit	Air cooling unit	Air cooling unit	PT 0231 BN
Accessories	PM S03 550	PM S03 551	PM S03 552	
Order number <b>without</b> display and control unit	PM S03 555	PM S03 556	PM S03 557	
Order number <b>with</b> display and control unit				

To correctly identify the product when communicating with Pfeiffer Vacuum, always have the information from the rating plate available.

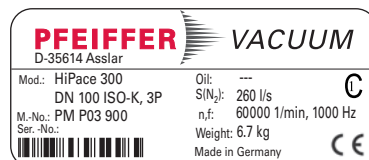

Fig. 1: Example for a rating plate

#### Scope of delivery

- HiCube 80 Eco
- Protective cover for the high vacuum flange
- Connection cable M12, 3 m length
- Operating manuals for pumping station and individual components

## 4.2 Function

Turbo pumping stations are fully automatic pump units which are ready for connection. A turbo pumping station consists of a portable or mobile vacuum pumping unit with a turbopump and a specially matched backing pump.

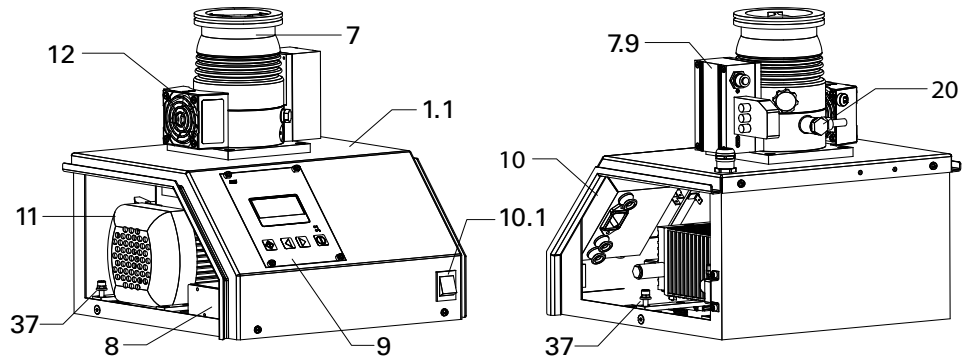

**Fig. 2: Views of HiCube 80 Eco**

1.1	Casing	9	Display and control unit DCU 002 (option)	12	Air cooling unit
7	Turbopump HiPace 80	10	Relay box	20	Fore-vacuum connection
7.9	Electronic drive unit TC 110	10.1	Main switch	37	Hexagon nut, transportation lock
8	Power supply pack TPS 110	11	Backing pump MVP 015-2		

The turbo pumping station HiCube 80 Eco is available with or without a display and control unit. The display and control unit DCU 002 is used to control and monitor the pumping station. The DCU can be detached from the pumping station and used together with a connection cable M12 (accessory) as a remote control.

### Cooling

- Air cooling
- Water cooling (optional)

In the case of excess temperature the electronic drive unit reduces the drive power automatically.

### Drive

Electronic drive unit of the turbopump

### 4.3 Range of application

The pumping station HiCube 80 Eco must be installed and operated in the following ambient conditions.

Installation location	weather protected (indoors)
Protection category	IP 20
Protection class	I
Ambient temperature	+5 °C to +30 °C with convection cooling without gas throughput +5 °C to +35 °C with air cooling +5 °C to +40 °C with water cooling
Relative humidity	max. 80 %, at $T \leq 31$ °C, up to max. 50% at $T \leq 40$ °C
Atmospheric pressure	750 hPa - 1060 hPa
Installation altitude	2000 m max.
Degree of pollution	2
Permissible surr. magnetic field	$\leq 3.3$ mT
Overvoltage category	II
Connection voltage TC	24 V DC $\pm 5\%$



#### Remarks to ambient conditions

The specified permissible ambient temperatures apply to operation of the turbopump at maximum permissible fore-vacuum pressure or at maximum gas throughput depending on the cooling method. The turbopump is intrinsically safe by a redundant temperature monitoring.

- By reducing the fore-vacuum pressure or gas throughput, the turbopump can be operated at higher ambient temperatures.
- If the maximum permissible operating temperature of the turbopump is exceeded, the electronic drive unit reduces drive power first and switches off then, if necessary.

## 5 Installation

### 5.1 Set-up

The installation location is to be chosen so that components that need servicing are freely accessible at all times. No special foundations or base are necessary for installation. The unit must not be used outdoors. Conditions are:

- the ambient conditions specified for the range of application
- a level, vibration-free surface.
- Distance to side walls or adjacent devices: at least 50 cm.
- Distance to possible edges of tables: at least 10 cm.
- When using a casing heating and a water cooling unit the temperature of the connected flange of the vacuum chamber must not exceed 120 °C.
- It is not allowed to operate the device in systems where impact-like stresses and vibrations or periodically forces occur.

### 5.2 Preparatory work

- Ensure sufficient cooling for the pumping station.
- Where magnetic fields > 3.3 mT are involved, a suitable shielding must be used. Check installation location and consult Pfeiffer Vacuum if needed!
- The maximum permissible rotor temperature for the turbopump is 90 °C. If high temperatures arise for process reasons, the radiated heat input must not exceed 0.9 W. Install suitable screening sheets, if necessary (design information on request).

### 5.3 Connecting the high vacuum side

The assembly of superstructures on the pumping station HiCube 80 Eco is in the operator's responsibility. The load capacity of the high vacuum flange is specific for the used turbopump. The gross weight of superstructures on the pumping station HiCube 80 Eco may **not** exceed 50 kg!

- Observe barycentric shifting by using high or lateral protruding superstructure (e.g. vacuum chamber). **Danger of tilting!**
- Install the high vacuum flange in accordance with the instructions in the operating manual of the turbopump.
- Ensure the greatest possible cleanliness when installing any high vacuum parts. Unclean components prolong the pump-down time.

If the rotor is suddenly blocked, the torques arising from the system and the high vacuum flange must be absorbed. Only the components listed in the following can be used to fasten the turbopumps to the high vacuum flange. The installation elements for turbopumps are special designs by Pfeiffer Vacuum. In all operating conditions, the tensile strength of the flange material must be at least 170 N/mm<sup>2</sup>.



#### NOTICE

##### Observe shape tolerances for the counter flange

Unevennesses of the customer supplied counter flange can lead to warping of the pump casing despite proper fastening. Leakiness and negative running characteristics can be the result.

- Do not exceed an evenness of max. 0.05 mm for the whole surface.



##### Mounting of ISO flanges

If the rotor suddenly blocks the connection of high vacuum flanges of types ISO-KF or ISO-K can lead to twisting despite proper installation.

- The tightness of the high vacuum flange is not at risk thereby.

### Use of a splinter shield or protection screen

Pfeiffer Vacuum centering rings with splinter shield or protection screen in the high vacuum flange protect the turbopump against foreign bodies coming from the chamber. Thus, the pumping speed of the pump is reduced.

	Reduced volume flow rate in %			
	H <sub>2</sub>	He	N <sub>2</sub>	Ar
Splinter shield DN 40	6	9	17	18
Splinter shield DN 63	3	6	15	16
Protection screen DN 63	1	1	4	4

### Vibration damper



#### WARNING

##### Danger from the turbopump and vibration damper being torn-off

In case of sudden blocking of the rotor, an applied vibration damper cannot compensate any of the occurring forces. There is a danger of the turbopump being torn-off and thereby resulting severest injuries and property damages. Applicable safeguards must be taken to compensate possible occurring torques.

- Definitely consult with Pfeiffer Vacuum.
- Do not exceed the max. permissible temperature at the vibration damper (100 °C).

### Installation of ISO-KF flange with ISO-KF flange

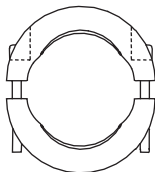

For the installation the following components are exclusively authorized:

- the valid mounting kit of the Pfeiffer Vacuum accessories programme
  - protection screen or splinter shield are optionally
- Mind that the sealing surfaces are not damaged.  
 → Flange the turbopump with the clamping ring.  
 → Tightening torque: 3.7 Nm.

### Installation of ISO-K flange with ISO-K flange

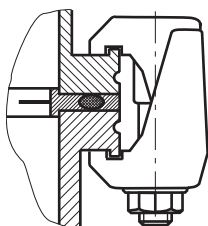

For the installation the following components are exclusively authorized:

- the valid mounting kit of the Pfeiffer Vacuum accessories programme
  - protection screen or splinter shield are optionally
- Mind that the sealing surfaces are not damaged.  
 → Connect the flanges according to the drawing and with the component parts of the mounting kit.  
 → Use the required number of 4 claw clamps.  
 → Tighten the claw clamps crosswise in three steps.  
 → Tightening torque: 5, 15, 25 ±2 Nm

### Installation of ISO-K flange with ISO-F flange

For the installation the following components are exclusively authorized:

- the valid mounting kit of the Pfeiffer Vacuum accessories programme
- protection screen or splinter shield are optionally

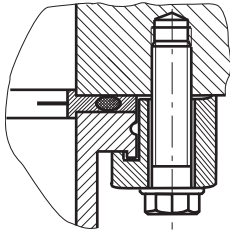

- Mind that the sealing surfaces are not damaged.
- Connect the flanges according to the drawing and with the component parts of the mounting kit.
- Use the required number of **4** claws.
- Tighten the claws crosswise in three steps.
- Tightening torque: 3, 10, 16 ±1 Nm.

### Installation of CF-flanges



#### NOTICE

##### **Assembly of CF flanges!**

Loss of sealing capability due to a lack of cleanliness when handling the sealing and CF flange.

- Assemble the sealing dry and oil-free.
- Always wear gloves when handling the components.
- Do not damage the surfaces and cutting edges.

The connection types for installation of CF to CF flange are "hexagon screw and through hole", "stud screw and threaded hole" as well as "stud screw and through hole".

For the installation the following components are exclusively authorized:

- the valid mounting kit of the Pfeiffer Vacuum accessories programme
- A copper seal
- protection screen or splinter shield are optionally

##### **Stud screw and threaded hole**

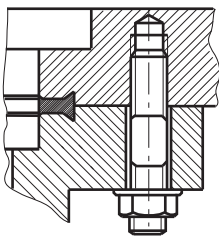

- If used: Insert protective screen or splinter shield with the clamping lugs downward into the high vacuum flange of the turbopump.
- Place the seal exactly in the hollow.
- Connect the flange using **8** stud screws (M8) with washers and nuts and tighten circularly with a torque of 22 ±2 Nm. After this, check the torque, since flowing of the sealing material may make it necessary to tighten the screws.

##### **Hexagon screw and through hole**

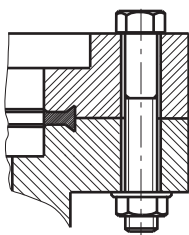

- If used: Insert protective screen or splinter shield with the clamping lugs downward into the high vacuum flange of the turbopump.
- Place the seal exactly in the hollow.
- Connect the flange using **8** hex screws (M8) with washers and nuts and tighten circularly with a torque of 22 ±2 Nm. After this, check the torque, since flowing of the sealing material may make it necessary to tighten the screws.

## 5.4 Connecting the exhaust side



#### CAUTION

##### **High pressure in the exhaust line!**

Danger of damage to the seals and danger of the pump bursting.

- Install the line without shut-off valves on the exhaust side.
- Do not operate the pump with excess pressure at the inlet; observe the maximum allowable pressures and pressure differences.

- Choose the cross-section of the exhaust line to be at least the size of the nominal connection diameter of the vacuum pump's exhaust connection.
- Piping to the pump must be suspended or supported.
  - Physical forces from the piping system must not be allowed to act on vacuum pumps.
- Lay piping from the pump sloping downward so that no condensate can flow back into the pump; otherwise fit a condensate separator.
  - If an air trap is created in the system, then a device for draining condensation water must be provided at the lowest point.

## 5.5 Connecting accessories



### Installation and operation of accessories

Pfeiffer Vacuum pumps can be equipped with a series of adapted accessories. The installation, operation and maintenance of connected devices are described in detail in the operating instructions of the individual components.

- For information on order numbers of components, see "Accessories".
- Use original accessory parts only.



### NOTICE

#### Note the factory settings.

The accessory connections on the turbopump have been preconfigured at the factory. Interchanging the control leads on the connector causes the pumping station to malfunction or fail.

- Do not interchange the control leads.
- Accessory connections can be configured for operation with the DCU.
  - For more information refer to the operating instructions for the electronic drive unit of the turbopump.



#### Accessory connection on the TC 110

The connection of Pfeiffer Vacuum accessory units to the electronic drive unit TC 110 is only possible by using respective connecting cables or adapters.

- Configure the preferred accessory output via RS-485 using a Pfeiffer Vacuum display and control unit or a PC.
- Consider the operating instructions "Electronic Drive Unit TC 110".

The pumping station is equipped with air cooling as a standard accessory.

## 5.6 Transportation lock

Turbo pumping stations of the HiCube 80 Eco line are equipped with a transportation lock for the backing pumps (see label). The backing pump is diagonally fixed with cylinder head screws with nuts via two spring loaded rails at the bottom plate of the pumping station.

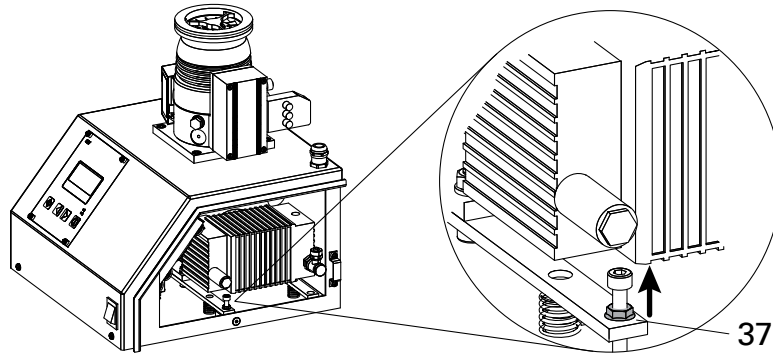

**Fig. 3: Transport protection for HiCube 80 Eco**

37 Transport protection

- Loosen the hexagon nut 37 of the transportation lock.
- Similarly loosen the transportation lock on the opposite side.

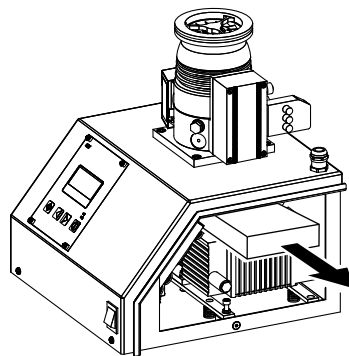

- Remove PE-foam padding above the backing pump from the casing.

## 5.7 Voltage range of the backing pump

The backing pump is driven by single-phase extended voltage range motors with reversible voltage ranges.



### NOTICE

#### Overvoltage!

An incorrect voltage range setting can damage the motor.

- Always check the voltage range before switching on the pumping station.
- Disconnect the mains supply before changing the voltage range of the backing pump.

- 180 ... 254 V, 50/60 Hz
- 90 ... 126 V, 50/60 Hz

- Set the desired voltage range on the voltage selector switch using a suitable screwdriver.



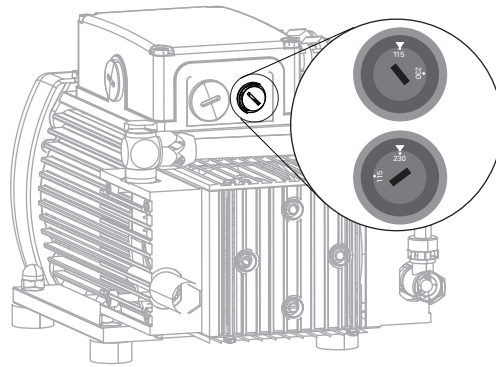

Switch position:	"115"	"230"
Voltage ranges:	90 ... 126 V; 50/60 Hz	180 ... 254 V; 50/60 Hz

Fig. 4: Switch position for the voltage range at the backing pump

## 5.8 Connecting to the mains power supply



### WARNING

#### Danger of unsafe electrical installation

Safe operation after installation is the responsibility of the operator.

- Do not independently modify or change the pump and electrical equipment.
- Make sure that the system is integrated in an emergency off safety circuit.
- Consult Pfeiffer Vacuum for special requirements.



### CAUTION

#### Automatic start

After connecting the supply voltage and switching on the main switch, pumping stations **without** display and control unit will run up immediately.

- Switch the mains switch to position "0" before plugging in the mains cable.
- Switch on the mains supply immediately before operation.

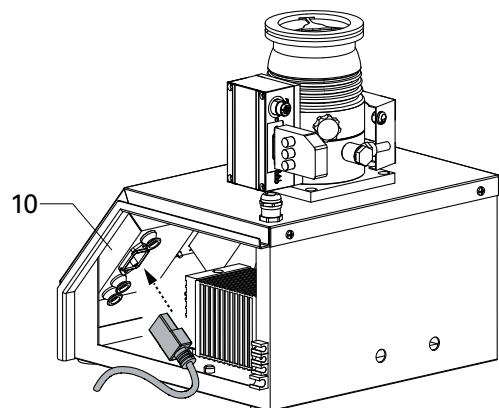

Fig. 5: Connecting the mains supply

10 Relay box

- Order the mains cable separately (see "accessories").
- Plug the mains cable into the the mains connection of the relay box.
- Connect the mains cable to the mains.
- Always ensure a safe connection to the protective earthing conductor (PE, protection class I).

## 6 Operation

### 6.1 Commissioning

The following important settings are programmed in the electronic drive unit ex factory.

- Parameter **[P:027]** Gas mode: 0 = heavy gases
- Parameter **[P:700]** Set value max. run-up time monitoring: 8 min
- Parameter **[P:701]** Rotation speed switchpoint: 80% of the nominal rotation speed
- Parameter **[P:707]** Set value rotation speed setting mode: 65% of the nominal rotation speed
- Parameter **[P:708]** Set value power consumption 70 % (may be only reduced)
- Parameter **[P:720]** Venting rotation speed at delayed venting: 50% of the nominal rotation speed
- Parameter **[P:721]** Venting time: 3600 s

→ When water cooling is used: Open cooling water supply and check the flow.

→ When sealing gas is used: Open the sealing gas supply and check the flow.



#### Comply run-up time

Pump throughput can be impaired by condensate or remaining moisture in the backing area. This can lead to exceeding the maximum run-up time.

→ **Recommendation:** When switching on, open the gas ballast valve for about 5 min. (see p. 20, chap. 6.4).

### 6.2 Operation modes

The following operation modes are available:

- Operation without operating unit
- Operation via RS-485 and Pfeiffer Vacuum display and control units or PC

### 6.3 Function description



#### WARNING

#### Danger due to open high vacuum flange

The rotor of the turbopump turns at high speed. If the high vacuum flange is open, there is a danger of cut injuries and that the pump can be destroyed by objects falling into it.

→ Never operate the pump with an open high vacuum flange.

#### Operation without operating unit



#### CAUTION

#### Automatic start

After connecting the supply voltage and switching on the main switch, pumping stations **without** display and control unit will run up immediately.

→ Switch the mains switch to position "0" before plugging in the mains cable.

→ Switch on the mains supply immediately before operation.

→ Switch on the pumping station at the master switch.

After switching on the main switch, the electronic drive unit of the turbopump performs a self-test to check the supply voltage. Once the self test has been successfully completed, the turbopump and the backing pump begin to operate.

## Operation with DCU

- Consider the following manuals for the operation via Pfeiffer Vacuum display and control units:
  - Operating instructions "DCU"
  - Operating instructions "Electronic drive unit"



- Switch on the mains supply via the main switch.
- Switch on the pumping station via button "ON/OFF" on the DCU 002.
- Settings are possible via the RS-485 by using DCU, HPU or PC.

### Use of the DCU as a remote control

The display and control unit can be removed from the pumping station and used as a remote control.

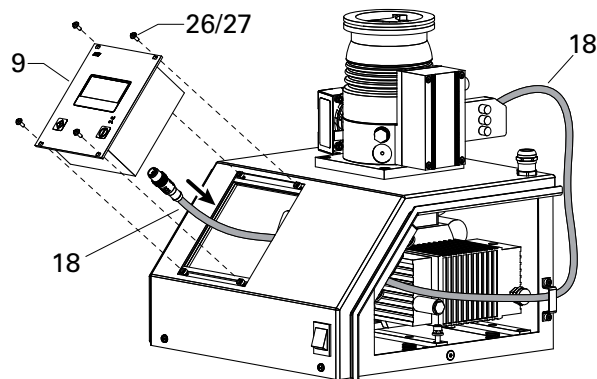

**Fig. 6: Setting up the DCU for use as a remote control**

9	Display and control unit	26	Fixing screw
18	Connection cable TC-DCU	27	Washer
19	Connection cable M12		PM 061 270 -X, Coupling M12

- Switch off the pumping station at the master switch.
- Disconnect the mains plug.
- Unscrew and remove the 4 fastening screws with washers from the front panel of the display and control unit.
- Lift out the display and control unit from the casing.
  - Be careful of the casing seal.
- Detach the connection cable from the DCU and remove from the pumping station frame.

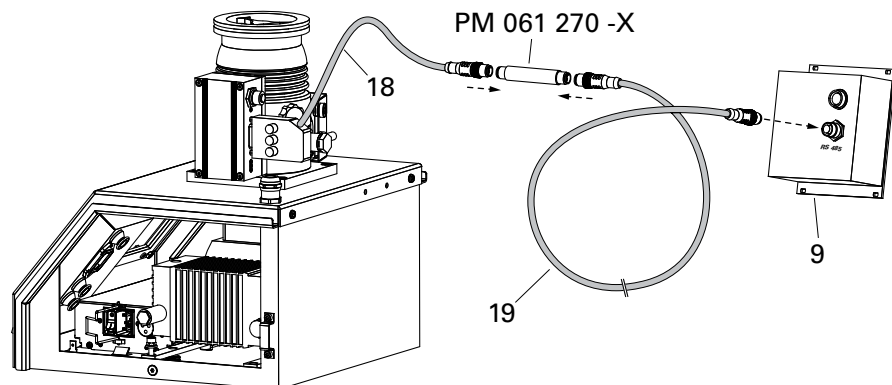

- Attach the connection cable 19 (delivery) as an extension with coupling PM 061 270 - X (accessory) to the connection RS485 of the display and control unit.
- **Option:** Swap the connecting cable 19 between the display and control unit and the electronic drive unit for a longer connection cable.
  - Other lengths on request.

## 6.4 Operation with gas ballast valve

Steam or moisture from pumped media can condense in the backing pump and hence impair the suction performance.

Letting in gas ballast improves the discharge of condensate, and the pump achieves the specified final vacuum more quickly. The gas ballast valve can be replaced with a flushing gas connection if necessary.

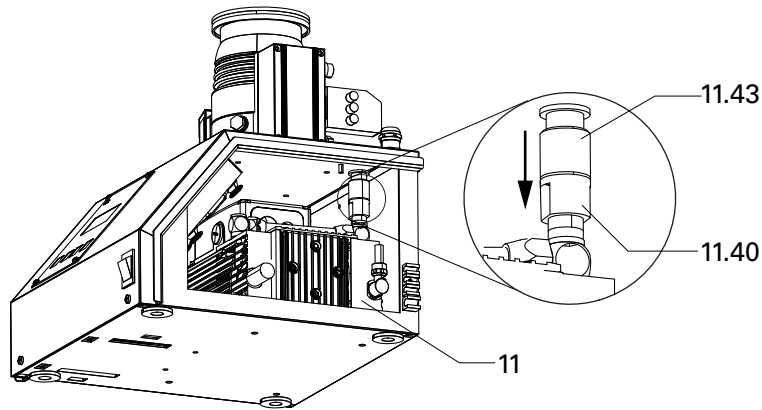

Fig. 7: Gas ballast valve of the backing pump

11 Backing pump MVP 015-2    11.40 Gas ballast valve    11.43 Sleeve

→ Open gas ballast valve; for this push down the sleeve of the gas ballast valve.

## 6.5 Monitoring of the operation conditions

### Operation display via LED

LEDs in the front panel of the electronic drive unit show basic operating conditions of the turbopump. A differentiated malfunction and warning display is possible only for operation with DCU or HPU.











LED	Symbol	LED status	Display	Meaning
Green 		Off	—	currentless
		On, flashing		"Pumping Station OFF", rotation speed $\leq 60 \text{ min}^{-1}$
		On, invers flashing		"Pumping Station ON", set rotation speed not attained
		On, constantly		"Pumping Station ON", set rotation speed attained
		On, blinking		"Pumping Station OFF", rotation speed $> 60 \text{ min}^{-1}$
Yellow 		Off	—	no warning
		On, constantly		Warning
Red 		Off	—	no malfunction
		On, constantly		Malfunction

Fig. 8: Behaviour and meaning of LEDs on the electronic drive unit

### Temperature monitoring

The drive power is reduced in case of impermissible motor temperature or impermissibly high housing temperature. This can cause falling below the rotation speed switchpoint and so result in turning off the turbopump.

## 6.6 Switching off and venting

### Switching off

After the turbopump is switched off, it must be vented to avoid contamination due to particles streaming back from the fore-vacuum area.



WARNING
<p><b>Danger of electric shock</b></p> <p>The pumping station is only free of voltages when the mains plug has been disconnected.</p> <ul style="list-style-type: none"> <li>→ Switch off the master switch and disconnect the mains plug before all work.</li> <li>→ Secure against unintentional restarting.</li> </ul>

#### Switching off without the DCU

- Switch off the pumping station at the master switch.
- Venting (possibilities, see below)
- For water cooling: Shut off the water supply.

#### Switching off with the DCU



- Switch off the pumping station via the "ON/OFF" button on the DCU.
- Switch off the pumping station at the master switch.
- Venting (possibilities, see below)
- For water cooling: Shut off the water supply.

### Venting

#### Manually venting

- Open the venting screw (included) in the venting connection of the turbopump about one turn.

#### Venting with Pfeiffer Vacuum Venting Valve

- Enable venting via the functions of the electronic drive unit.
- Settings are possible via the RS-485 by using DCU, HPU or PC.

Venting rotation speed	Switch off the pumping station	Mains power failure <sup>1)</sup>
50% of the nominal rotation speed	Venting valve opens for 3600 s (1 h, works setting)	Venting valve opens for 3600 s (1 h, works setting)

<sup>1)</sup>When mains power is restored the venting procedure is aborted.

#### Basic information for the rapid venting

Venting of the vacuum chamber in two steps. Ask for details on individual solutions from Pfeiffer Vacuum.

- Vent for 20 seconds at a rate of pressure rise of max. 15 hPa/s.
  - The valve cross section for the venting rate of 15 hPa/s must be adapted to the size of the vacuum chamber.
  - For small vacuum chambers, use the Pfeiffer Vacuum venting valve.
- Then vent with an additional venting valve of any desired size.

## 7 Maintenance / replacement



### WARNING

#### Contamination of parts and operating fluid by pumped media is possible.

Poisoning hazard through contact with materials that damage health.

- In the case of contamination, carry out appropriate safety precautions in order to prevent danger to health through dangerous substances.
- Decontaminate affected parts before carrying out maintenance work.



### NOTICE

#### Disclaimer of liability

Pfeiffer Vacuum accepts no liability for personal injury or material damage, losses or operating malfunctions due to improperly performed maintenance. The liability and warranty entitlement expires.



### WARNING

#### Danger of electric shock

The pumping station is only free of voltages when the mains plug has been disconnected.

- Switch off the master switch and disconnect the mains plug before all work.
- Secure against unintentional restarting.



### 7.1 Maintenance intervals and responsibilities

- Clean the pumping station externally with a lint-free cloth and little industrial alcohol.
- Carry out the required maintenance on the components of the pumping station in accordance with the instructions in the individual operating manuals.
- Clarify shorter maintenance intervals for extreme loads or impure processes with Pfeiffer Vacuum Service.
- For all other cleaning, maintenance or repair work, please contact your Pfeiffer Vacuum service location.

### 7.2 Removal of components for their maintenance

In some cases, components may need to be dismantled from the pumping station so that customers can carry out necessary maintenance work on them (they should then be re-assembled in reverse order).



### NOTICE

#### Refer to the notes on Proper Use of the unit.

The pumping station must only be operated as a complete unit. Disassembly and operation of individual pumping station components is deemed to be improper use.

- In this case the declaration of conformity will become invalid.

#### Dismantling connections

- Switch off the pumping station at the master switch.
- Disconnect the mains plug.
- Pull out the mains cable from the relay box.
- Pull out the mains supply cable (x2) for components from the relay box.
- Take off the connector from the electronic drive unit TC 110.
- Detach the accessory control lines from the connector and remove them.



### NOTICE

#### Note the factory settings.

The accessory connections on the turbopump have been preconfigured at the factory. Interchanging the control leads on the connector causes the pumping station to malfunction or fail.

- Do not interchange the control leads.
- Accessory connections can be configured for operation with the DCU.
  - For more information refer to the operating instructions for the electronic drive unit of the turbopump.

Connection to X3	Preset accessory
acc. A1	Air cooling unit
acc. B1	Venting valve
acc. DO1	Backing pump

Overview of factory preconfigured accessory connections on the HiCube 80 Eco

## Dismantling of the turbopump

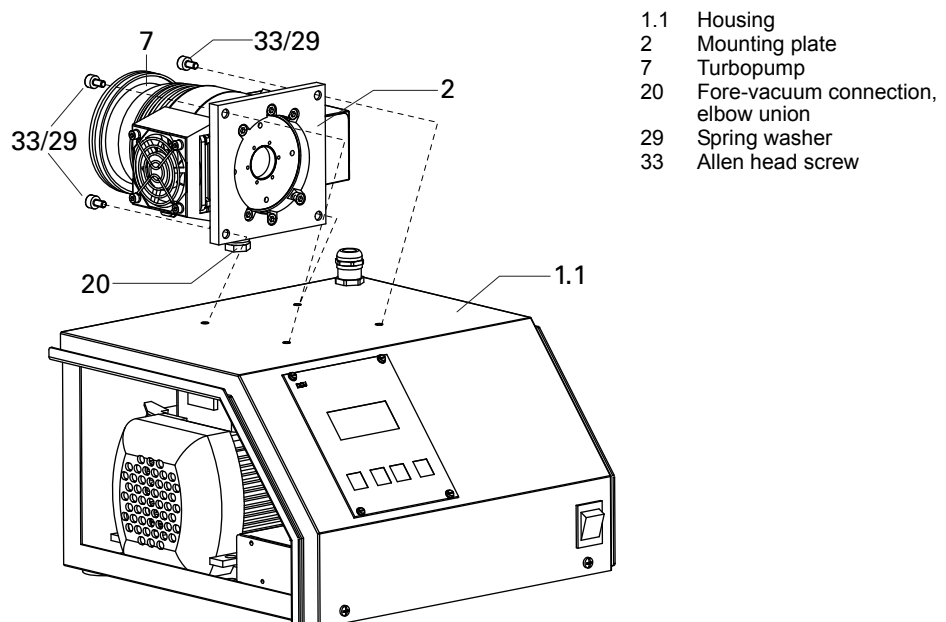
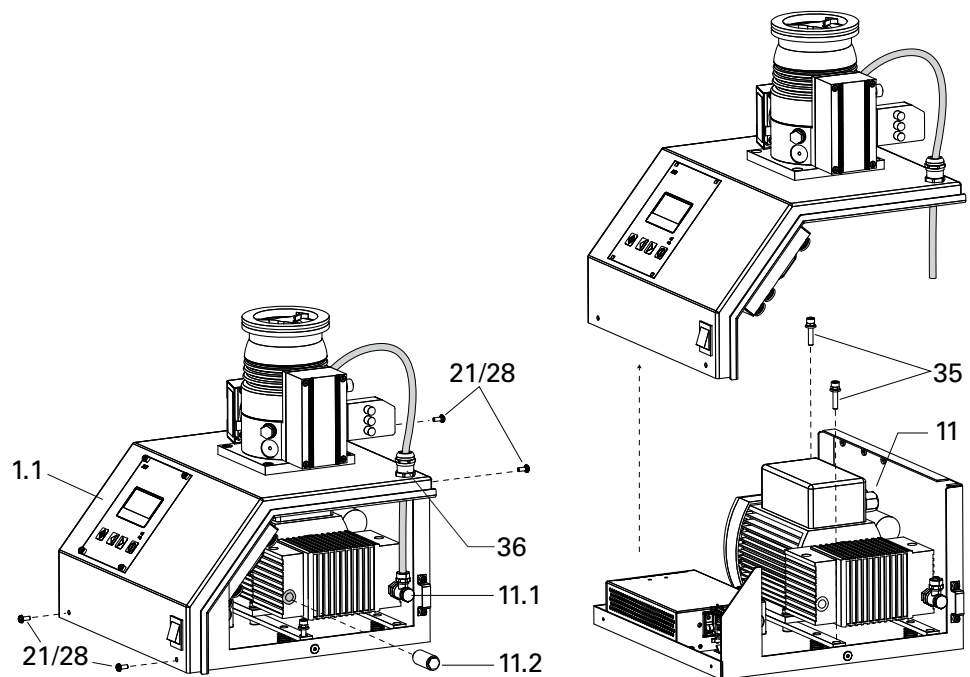

Fig. 9: Disassembly of the turbopump

- Detach the fore-vacuum line from the turbopump and take it off.
  - Do not kink or damage the fore-vacuum hose.
- Unscrew and remove all Allen head screws 95 (7x) from the mounting plate.
  - Tightening torque for the fixing screws when mounted: 10 Nm
- Take off the turbopump with the mounting plate from the casing.

The opening in the mounting plate makes it easy for customers to perform maintenance work on the turbopump (e.g. change the lubricant reservoir).

## Removing the backing pump



**Fig. 10: Disassembly of the diaphragm pump from the pumping stand frame**

1.1 Casing	11.2 Exhaust silencer	35 Cylinder screw
11 Baking pump	21 Casing screw	36 Clamping screw
11.1 Vacuum connection backing pump	28 Washer	

- ➔ Detach the fore-vacuum line from the vacuum connection of the diaphragm pump and take it off.
  - Do not kink or damage the fore-vacuum hose.
- ➔ Unscrew and remove the casing screws and washers on the front and rear of the pumping stand frame.
- ➔ Take off the casing with turbopump, display and control unit and relay box from the pumping stand frame.
  - Observe the connection cables!
- ➔ Unscrew the exhaust silencer by hand from the backing pump.
- ➔ Unscrew the two cylinder screws 35 (Allen head) from the bottom plate of the pumping station so that the backing pump is loosened.
- ➔ Lift out the backing pump above the top of the pumping station frame.



## 8 Decommissioning

### 8.1 Shutting down for longer periods



#### WARNING

**Contamination of parts and operating fluid by pumped media is possible.**

Poisoning hazard through contact with materials that damage health.

- In the case of contamination, carry out appropriate safety precautions in order to prevent danger to health through dangerous substances.
- Decontaminate affected parts before carrying out maintenance work.

If the pumping station should be shut down for longer than a year:

- Remove the pumping station from the system, if necessary.
- Change the operating fluid reservoir of the turbopump.
- Only store the pumping station indoors at an ambient temperature between -10 °C and +40 °C.
- In rooms with moist or aggressive atmospheres, the pumping station must be airtight and shrink-wrapped in a plastic bag together with a bag of desiccant.

### 8.2 Re-starting



#### NOTICE

##### Restarting

The serviceability of the operating fluid of the turbopump without operation is a maximum of 4 years. Before restarting after a shut-down of **4 years or longer**, carry out the following work:

- Replace the operating fluid reservoir
- Replace bearings
- Follow the maintenance instructions and inform Pfeiffer Vacuum
- Check pumping station for contamination and moisture.
- Clean the pumping station externally with a lint-free cloth and little industrial alcohol.
- If necessary, have Pfeiffer Vacuum Service clean the pumping station completely.
- Installation and commissioning in accordance with the operating instructions.

### 8.3 Disposal

Products or parts thereof (mechanical and electrical components, operating fluids, etc.) may cause environmental burden.

- Safely dispose of the materials according to the locally applicable regulations.

## 9 Malfunctions

Malfunctions on the pumping station are usually caused by faults on individual components. Faults are indicated by the LEDs at the electronic drive unit of the turbopump. Alternatively, a fault code can also be output at the display and control unit DCU.

- Please refer to the relevant operating manual for troubleshooting at pumping station components.
- If no display and control unit is available, please contact the Pfeiffer Vacuum Service.

### 9.1 Rectifying malfunctions

Problem	Possible causes	Remedy
Pumping station will not start; none of the integrated LEDs on the electronic drive unit of the turbopump light up	• Electrical supply interrupted	⇒ Check the plug contacts at the relay box and the power supply unit. ⇒ Check the supply lines of the pumping station. ⇒ Check the output voltage (24 V DC) at the "DC out" terminal of the power supply unit ⇒ Check the plug contacts on the power supply unit
	• Incorrect operating voltage	⇒ Apply correct operating voltage ⇒ Observe the ratings on the type plate.
	• No operating voltage applied	⇒ Apply the correct operating voltage.
	• Electronic drive unit defective	⇒ Replace the electronic drive unit. ⇒ Contact Pfeiffer Vacuum Service.
Pump not achieving the required ultimate pressure	• Condensate in the backing pump	⇒ Open the gas ballast valve at the backing pump.
	• Gas ballast valve open	⇒ Close the gas ballast valve at the backing pump.

## 10 Service

### Pfeiffer Vacuum offers first-class service!

- Operating fluid and bearing change on the spot by Pfeiffer Vacuum FieldService
- Maintenance / repair in the nearby ServiceCenter or ServicePoint
- Fast replacement with exchange products in mint condition
- Advice on the most cost-efficient and quickest solution

Detailed information, addresses and forms at: [www.pfeiffer-vacuum.com](http://www.pfeiffer-vacuum.com) (Service).

### Maintenance and repair in the Pfeiffer Vacuum ServiceCenter

The following steps are necessary to ensure a fast, smooth servicing process:

- Download the forms "Service Request" and "Declaration on Contamination".<sup>1)</sup>
- Fill out the "Service Request" form and send it by fax or e-mail to your Pfeiffer Vacuum service address.
- Include the confirmation on the service request from Pfeiffer Vacuum with your shipment.
- Fill out the declaration on contamination and include it in the shipment (required!).
- Dismantle all accessories.
- Drain the operating fluid (applies for turbopumps with pumping speed > 700 l/s).
- Leave electronic drive on the pump.
- Close the flange openings by using the original protective covers.
- If possible, send pump or unit in the original packaging.

### Sending of contaminated pumps or devices

No units will be accepted if they are contaminated with micro-biological, explosive or radioactive substances. "Hazardous substances" are substances and compounds in accordance with the hazardous goods directive (current version). If pumps are contaminated or the declaration on contamination is missing, Pfeiffer Vacuum performs decontamination at the shipper's expense.

- Neutralise the pump by flushing it with nitrogen or dry air.
- Close all openings airtight.
- Seal the pump or unit in suitable protective film.
- Return the pump/unit only in a suitable and sturdy transport container and send it in while following applicable transport conditions.

### Exchange unit

The factory operating parameters are always preset with exchange units. If you use changed parameters for your application, you have to set these again.

### Service orders

All service orders are carried out exclusively according to our repair conditions for vacuum units and components.

<sup>1)</sup> Forms under [www.pfeiffer-vacuum.com](http://www.pfeiffer-vacuum.com)

## 11 Spare parts HiCube 80 Eco

Please also specify model number of the the rating plate when ordering accessories or spare parts.

Refer to the operating manuals for the individual components.

## 12 Accessories

<b>Designation</b>	<b>HiCube 80 Eco</b>
Mains cable 230 V AC, CEE 7/7 to C13, 3 m	P 4564 309 ZA
Mains cable 208 V AC, NEMA 6-15 to C13, 3 m	P 4564 309 ZF
Mains cable 115 V AC, NEMA 5-15 to C13, 3 m	P 4564 309 ZE

## 13 Technical data and dimensions

### 13.1 General

Basic principles for the Technical Data of Pfeiffer Vacuum Turbopumps:

- Recommendations of PNEUROP committee PN5
- ISO 21360; 2007: "Vacuum technology - Standard methods for measuring vacuum-pump performance - General description"
- ISO 5302; 2003: "Vacuum technology - Turbomolecular pumps - Measurement of performance characteristics"
- Ultimate pressure: using a test dome and a 48 hrs. period of baking out
- Gas throughput: water cooling; backing pump = rotary vane pump (10 m<sup>3</sup>/h)
- Cooling water consumption: at max. gas throughput, cooling water temp. 25 °C
- Integral leak rate: using a Helium concentration of 100 %, period 10 s
- Sound pressure level: Distance 1 m to the pump

**Conversion table: pressure units**

	mbar	bar	Pa	hPa	kPa	Torr mm Hg
mbar	1	$1 \cdot 10^{-3}$	100	1	0.1	0.75
bar	1000	1	$1 \cdot 10^5$	1000	100	750
Pa	0.01	$1 \cdot 10^{-5}$	1	0.01	$1 \cdot 10^{-3}$	$7.5 \cdot 10^{-3}$
hPa	1	$1 \cdot 10^{-3}$	100	1	0.1	0.75
kPa	10	0.01	1000	10	1	7.5
Torr mm Hg	1.33	$1.33 \cdot 10^{-3}$	133.32	1.33	0.133	1

$1 \text{ Pa} = 1 \text{ N/m}^2$

**Conversion table: gas throughput units**

	mbar·l/s	Pa·m <sup>3</sup> /s	sccm	Torr·l/s	atm·cm <sup>3</sup> /s
mbar·l/s	1	0.1	59.2	0.75	0.987
Pa·m <sup>3</sup> /s	10	1	592	7.5	9.87
sccm	$1.69 \cdot 10^{-2}$	$1.69 \cdot 10^{-3}$	1	$1.27 \cdot 10^{-2}$	$1.67 \cdot 10^{-2}$
Torr·l/s	1.33	0.133	78.9	1	1.32
atm·cm <sup>3</sup> /s	1.01	0.101	59.8	0.76	1

### 13.2 Technical data

Parameter	HiCube 80 Eco	HiCube 80 Eco	HiCube 80 Eco
Flange (in)	DN 63 ISO-K	DN 63 CF-F	DN 40 ISO-KF
Pumping speed for N <sub>2</sub>	67 l/s	67 l/s	35 l/s
Pumping speed backing pump at 50 Hz	0.50 m <sup>3</sup> /h	0.50 m <sup>3</sup> /h	0.50 m <sup>3</sup> /h
Ultimate pressure	$< 1 \cdot 10^{-7}$ hPa	$< 1 \cdot 10^{-7}$ hPa	$< 1 \cdot 10^{-7}$ hPa
Sound pressure level	≤ 52 dB (A)	≤ 52 dB (A)	≤ 52 dB (A)
Mains requirement	115 V, 50/60 Hz; 230 V, 50/60 Hz	115 V, 50/60 Hz; 230 V, 50/60 Hz	115 V, 50/60 Hz; 230 V, 50/60 Hz
Mains requirement: power consumption	230 W	230 W	230 W
Weight	17 kg	17 kg	17 kg
Backing pump	MVP 015	MVP 015	MVP 015

### 13.3 Dimensions

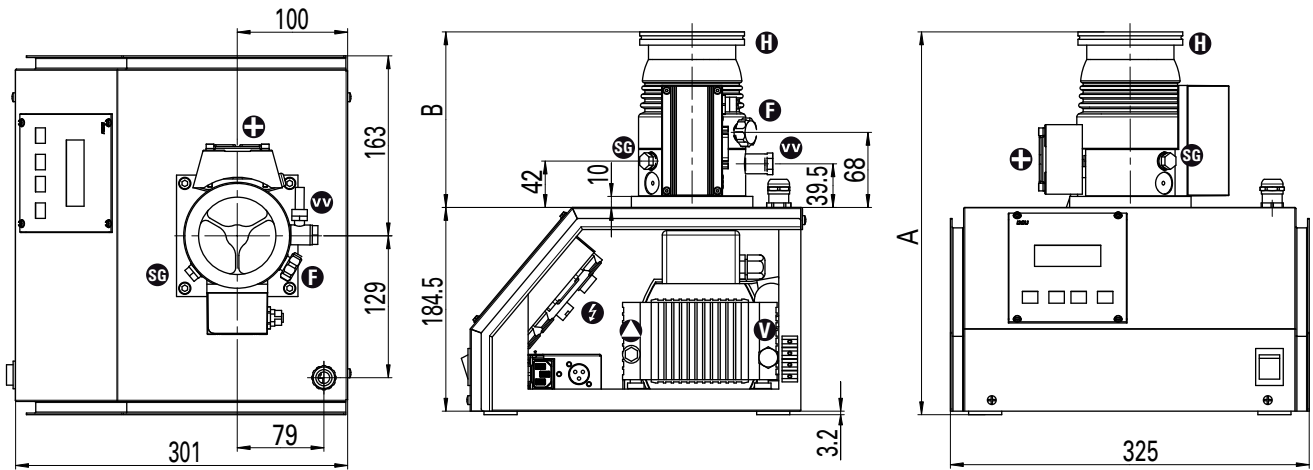

Dimensions	HiCube 80 Eco	HiCube 80 Eco	HiCube 80 Eco
Flange (in)	DN 63 ISO-K	DN 63 CF-F	DN 40 ISO-KF
A	347 mm	349.5 mm	352.5 mm
B	159 mm	165 mm	168 mm



# Declaration of conformity

We hereby declare that the product cited below satisfies all relevant provisions according to the following **EC directives**:

- **Machinery 2006/42/EC (Annex II, no. 1 A)**
- **Electromagnetic Compatibility 2004/108/EC**

The agent responsible for compiling the technical documentation is Mr. Helmut Bernhardt, Pfeiffer Vacuum GmbH, Berliner Straße 43, 35614 Asslar.

**HiCube**

**HiCube 80 Eco**

Harmonised standards and national standards and specifications which have been applied:

DIN EN ISO 12100 : 2011-03

DIN EN 61326-1 : 2006

DIN EN 1012-2 : 1996

DIN EN 62061 : 2005

DIN EN 61010-1 : 2010

Semi F47-0200

DIN EN 61000-3-2 : 2008

DIN EN 61000-3-3 : 2006

Signatures:

Pfeiffer Vacuum GmbH  
Berliner Straße 43  
35614 Asslar  
Germany

---

(M. Bender)  
Managing Director

(Dr. M. Wiemer)  
Managing Director

CE/2014

**Vacuum solutions  
from a single source**

Pfeiffer Vacuum stands for innovative and custom vacuum solutions worldwide, technological perfection, competent advice and reliable service.

**Complete range  
of products**

From a single component to complex systems: We are the only supplier of vacuum technology that provides a complete product portfolio.

**Competence in  
theory and practice**

Benefit from our know-how and our portfolio of training opportunities! We support you with your plant layout and provide first-class on-site service worldwide.

**Are you looking for a  
perfect vacuum solution?  
Please contact us**

**Pfeiffer Vacuum GmbH**  
Headquarters • Germany  
T +49 6441 802-0  
info@pfeiffer-vacuum.de